



JINCHENG HARDWARE INDUSTRY CO.,LTD

Add: No. 191,Wudong Industrial Zone,
Lile Town, Jianghai Dist, Jiangmen,
Guangdong, China 529060.

Tel: +86-750-3166208

Fax: +86-750-3166206

E-mail: sales@jincheng-hw.cc

http: //www.jincheng-hw.cc



JINCHENG

Door • Window • Glass





ABOUT US

JinCheng Hardware Industry Co.,Ltd is a manufacturer and supplier of architectural hardware to the construction industry, is located at Jiangmen city, Guangdong province in China Near HK and Macao. JinCheng products are both durable and versatile.

The JinCheng quality range of Architectural Hardware includes door hinges, Door Lever handles, pull handles, door stoppers, series of door-used hardware and small size metal components, etc. We focus on customers service, high quality and competitive price, which leading our goods are popular in America, Canada, Europe, Southeast. Asia, Middle-East and other countries abroad.

JinCheng's extensive range of Architectural Hardware products offers a well-priced package of functionality and style. Please feel free to contact JinCheng if you have any special requirements or you would like one of our architectural consultants to call on you. We look forward to helping you and thank you for your interest and support.

CONTENTS



1

Lever Handle

EN1906 Certificated Handle	1-0-1
S/S Hollow	1-1-1
S/S Solid	1-2-1
Brass	1-3-1
Zinc Alloy	1-4-1
Aluminum	1-5-1
Rosette, escutcheon & spindle	1-6-1
Window Handle	1-7-1



2

Hinge

EN1935 Certification S/S Hinge	2-0-1
Stainless Steel	2-1-1
Brass	2-2-1
Other	2-3-1



3

Mortise Lock & Cylinder

Mortise Lock	3-1-1
Cylinder	3-2-1
American Style Brass Handle	3-3-1



4

Pull Handle

Hollow(tube)	4-1-1
Solid	4-2-1



5

Door Closer

Door Closer	5-1-1
-------------------	-------



Accessory

Door Stopper	6-1-1
Door Holder	6-2-1
Door Guard	6-3-1
Door Bolt	6-4-1
Dust Proof Strike	6-5-1
Door Viewer	6-6-1
Ball Catch	6-7-1
Door Coordinator	6-8-1
Mirror Screw	6-9-1
Glass Holder	6-10-1
Door Bell	6-11-1
Number & Mail Box	6-12-1
Furniture Conceal Handle	6-13-1
Furniture Handle	6-14-1
Furniture Konb	6-15-1
Hook	6-16-1
Hang Wheel	6-17-1
Furniture Drawer	6-18-1
UL Panic Exit Device	6-19-1
Cup Handle	6-20-1
Sign Plate	6-21-1
Washroom Fitting	6-22-1
Washroom Cubicle	6-23-1
Handrail System	6-24-1



Certification

Icon Legends	7-1-1
Certification	7-2-1



MATERIALS

MATERIALS

STAINLESS STEEL

The majority of products supplied by JinCheng Hardware are manufactured in stainless steel grade AISI 304 and 316. Stainless steel is outstanding in its suitability for door and window fittings its surface is extremely resistant to corrosion. Even when roughly treated it scarcely shows traces of dents and above all, it requires very little care. An invisible passive layer forms on its surface, which is even supposed to have anti-bacterial properties.

All this ensures the products are ideal for our modern buildings. The flexible range of products can be used anywhere indoor as well as outdoor, for houses and buildings, and combined in innumerable ways.

ALUMINUM

Aluminum has always been used as a high-tech material when lightweight and durability are required. The natural colour of aluminum is silver - like - and like stainless steel, it fits very well into our modern buildings.

In daily use, aluminum surfaces can be worn or scratched by harder materials. This "damage" to the aluminum surface may impair the aesthetic of the impression, but has no effect on the products function. Many users even like the patina resulting from daily use.

BRASS

Brass is a warm glowing material and has been on the market for many years. Brass comes in many different variations and alloys which all give the individual products their own characteristics. When not treated with a varnish or waxed real brass will corrode over time giving it a brown to grey-green patina.

The main part of the brass products we supply have all been varnished to prevent the natural patina from occurring. This means the brass products does not have to be polished or cleaned on a weekly basis - and thereby gives you the possibility of using brass - even in high traffic areas.

ZINC ALLOY

Zinc is an essential mineral, including to prenatal and postnatal development.[9] Zinc deficiency affects about two billion people in the developing world and is associated with many diseases.

A widely used zinc alloy is brass, in which copper is alloyed with anywhere from 3% to 45% zinc, depending upon the type of brass. Other widely used zinc alloys include nickel silver, typewriter metal, soft and aluminium solder, and commercial bronze. Zinc is also used in contemporary pipe organs as a substitute for the traditional lead/tin alloy in pipes. Alloys of 85–88% zinc, 4–10% copper, and 2–8% aluminium find limited use in certain types of machine bearings.



FINISHES

FINISHES.

Many of our products are available in both satin stainless steel and polished stainless steel or in the silver-like aluminum finish that grows more and more popular. For the classic look, the brass products are always in demand and with the different finishes in either brass, polished brass or antique look we guarantee we are able to find the right solution for you. In addition, we also have several products in bronze for the more reddish, warm glow.

Some of our products are available in even more finishes than we have in our catalogue - please feel free to ask if you require a specific finish, but cannot find it here.

In order for you to easily detect which products is available in which finish - we have included the material and finish in the fact box on each product page.

FINISHES AVAILABLE:



SS
(Satin stainless steel)



P&L
(Polish and lacquered)



GP
(Gold plated)



AB
(Antique brass plated)



PSS
(Polished stainless steel)



S&L
(Satin and lacquered)



BP
(Brass plated)



AC
(Antique copper plated)



DOOR HANDLES





STANDARDS

CLASSIFICATIONS

Door handles and knobs come in a variety of materials, designs and qualities. In order to be able to compare the different door handles they need to conform to a set of classification standards. For door handles and knobs, the relevant DIN EN standards are mentioned below.

DIN EN 1906 - BUILDING HARDWARE

Door furniture conforming to DIN EN 1906 is classified by an 8-digit code system. A similar classification applies to all building hardware product standards so that complementary items of hardware can be specified to, for example, a common level of corrosion resistance, the use on smoke / fire doors etc.

Each digit of the classification refers to a particular feature of the product measured against the standards performance requirements. The background of these requirements is to simulate actual everyday use. This is achieved by defining load requirements and taking subsequent clearance measurements before and after continuous function tests on the hardware.

The digits' practical value and the categorisation of the levers and knobs must be judged using the entire classification scheme. Only the total of all test criteria and test results lead to DIN EN 1906.

Digit 1 - Category of use - 4 grades are identified.

- Grade 1 Medium frequency of use with high incentive to exercise care with small chance of misuse e.g. internal residential doors.
- Grade 2 Medium frequency of use with high incentive to exercise care and some chance of misuse e.g. internal residential doors.
- Grade 3 High frequency of use by the public or others with little incentive to exercise care and high chance of misuse e.g. public office doors.
- Grade 4 High frequency of use on doors subject to frequent violent use or damage e.g. doors in sport stadiums or public buildings

Digit 2 - Durability- 2 grades are identified.

- Grade 6 - 100.000 test cycles
- Grade 7 - 200.000 test cycles

The tests undertaken to achieve these grades involve the application of additional forces to the door furniture in order to simulate the conditions of use likely to be experienced in the field.

Digit 3 - Door dimensions

No classification defined.



DOORS

Digit 4 - Fire resistance - 4 grades are identified

Grade 0 No performance defined

Grade A Suitable for installation in smoke control doors

Grade B Suitable for installation in smoke control and fire doors.

Grade C Suitable for installation in smoke control and fire doors with lever handle core requirements.

Digit 5 - Safety - 2 grades are identified

Grade 0 For normal use

Grade 1 Safety requirements

To qualify for a grade 1, handles must have high strength handle-to-plate and plate-to-door fixing and/or handle-to spindle fixing, such that they would withstand a person grabbing in order to prevent falling. It is recommended that only safety furniture be used at the top of cellar steps or other staircases.

Digit 6 - Corrosion resistance - 5 grades are identified

Grade 0 No classification identified

Grade 1 Low corrosion resistance (24h salt spray test)

Grade 2 Moderate corrosion resistance (48h salt spray test)

Grade 3 High corrosion resistance (96h salt spray test)

Grade 4 Extremely high corrosion (240h salt spray test)

Grade 5 Extraordinary high corrosion resistance (480h salt spray test)

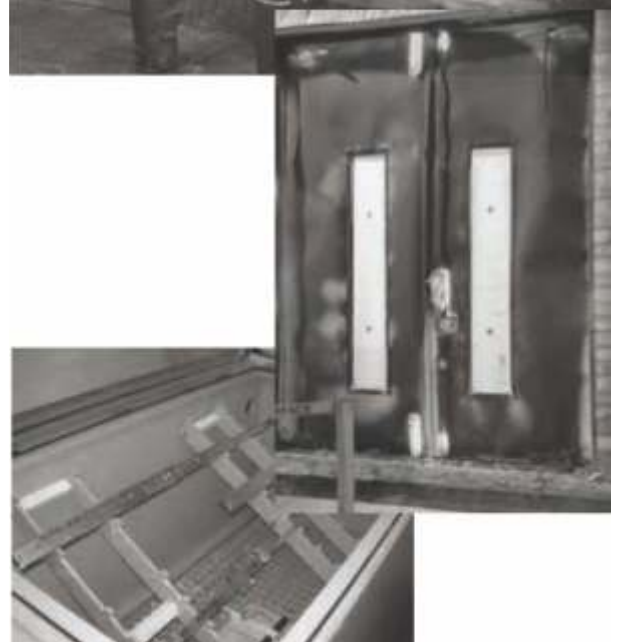



STANDARDS

CLASSIFICATIONS

Digit 7- Security - 4 grades are identified

- Grade 0 Not burglary resistant
- Grade 1 Low burglary resistance
- Grade 2 Moderate burglary resistance
- Grade 3 High burglary resistance
- Grade 4 Extra high burglary resistance

The main requirements include resistance to drilling, close fitting plates or escutcheons to help protect the lock and support the cylinder. They must resist removal from the outside of the door.

Digit 8 - Type of operation - 3 grades are identified

- Grade A Spring assisted
- Grade B Spring loaded
- Grade U Unsprung

DIN EN 179 - EMERGENCY EXIT DEVICES

Building regulations require that the doors in escape routes should be easy to open from inside to their full width - with a handle if necessary. The standards define the manufacturing, suitability for use and testing requirements concerning fire exit locking systems. These requirements are only valid for leaf doors with a maximum weight of 200 kg, height of 2,500mm,

This certification specifies testing procedures and the technical requirements with regard to:

- Mechanical fire exit locking systems that are operated using an operational handle.
- Mechanical fire exit locking systems that are operated using a push plate.

Combinations of fittings as understood by DIN EN 179 must be considered as products subject to building regulations with the necessary EU and CE conformity labels. They consist of lock, locking plate and door furniture and must always be tested and certified together.

Note:

If it is not certain that all people in the building are familiar with fire exits and their operations, and/or if there is a risk of panic, use must be made of the products tested according to DIN EN 1125. (panic locks operated by a horizontal bar)





DIN 107 - DIRECTION

A differentiation is made between DIN left and DIN right doors depending on the rotational direction of the door. The door direction or side designation according to DIN 107 is determined as follows:

Visible seal of the door hinges on the right = DIN right
 Visible seal of the door hinges on the left = DIN left

OPENING TO THE OUTSIDE



DIN RIGHT

DIN LEFT

OPENING TO THE OUTSIDE



DIN RIGHT

DIN LEFT





Lever Handle

- En1906 Certificated Handle
- 1-1: S/S Hollow
- 1-2: S/S Solid
- 1-3: Brass
- 1-4: Zinc Alloy
- 1-5: Aluminum
- 1-6: Rosette, escutcheon & spindle
- 1-7: Window Handle

JTH101-EN4	JTH102-EN4	JTH104-EN4
		
JLH004-EN4	JLH024-EN4	JLH041-EN4
		
JLH046-EN4	JLH051-EN4	
		

1	2	3	4	5	6	7	8
Category of use:	Test cycles/ Durability	Door mass	Fire resistance	Safety	Corrosion resistance	Security	Type of operation
1,2,3,4	6,7	No classification	0 or A/A1/B/B1 C/C1/D/D1	0 or 1	0,1,2,3,4	0,1,2,3,4	A,B,U

4
7
-
B
0
3
0
B

JTH101



JTH102

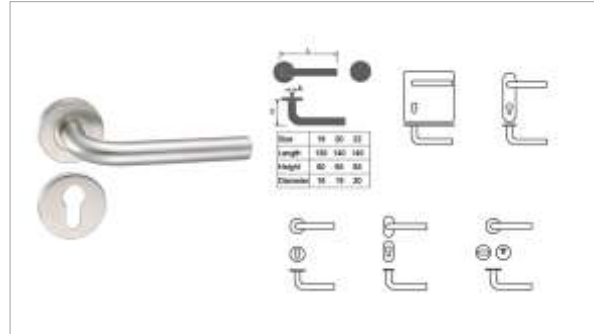

JTH103

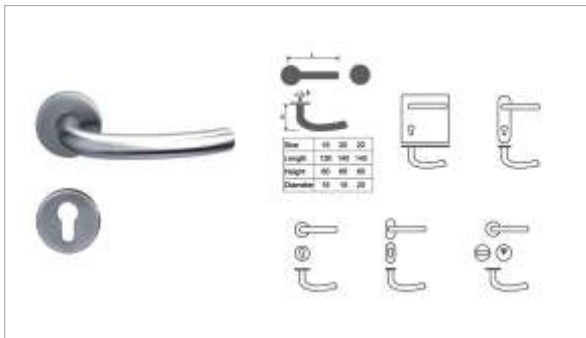

JTH104

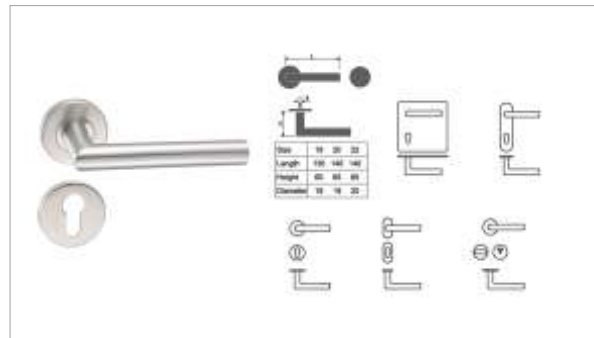

JTH105

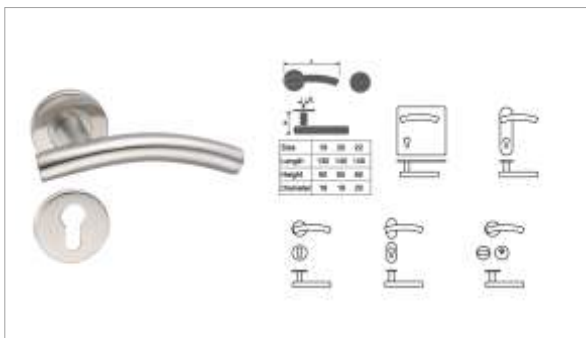

JTH106

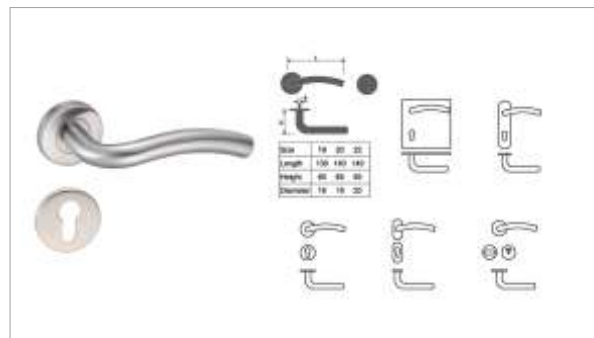

JTH107

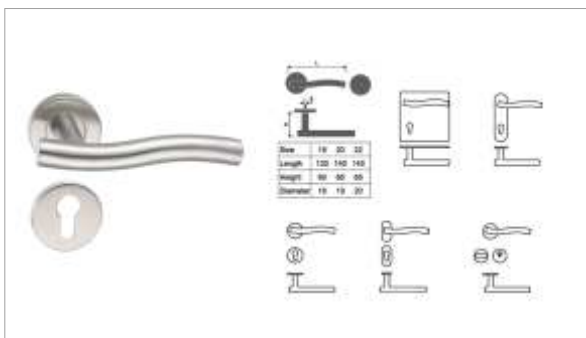

JTH108

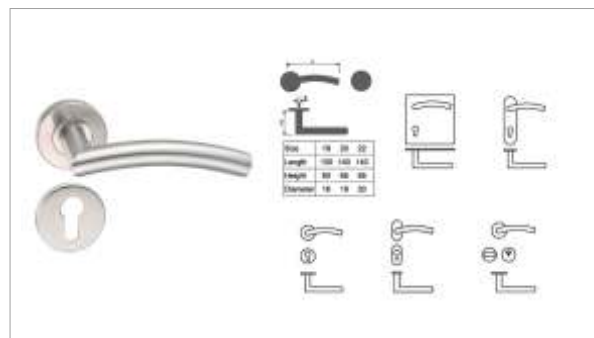

JTH109

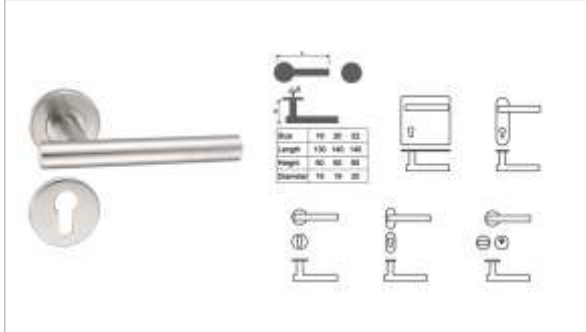

JTH110

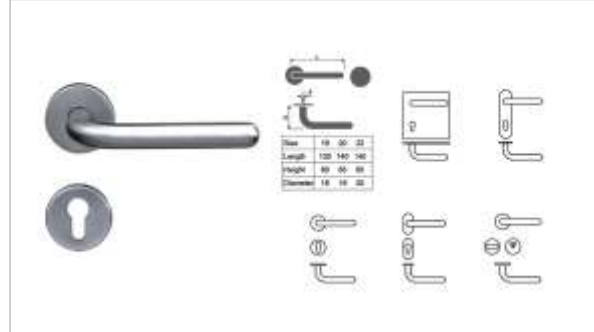

JTH111

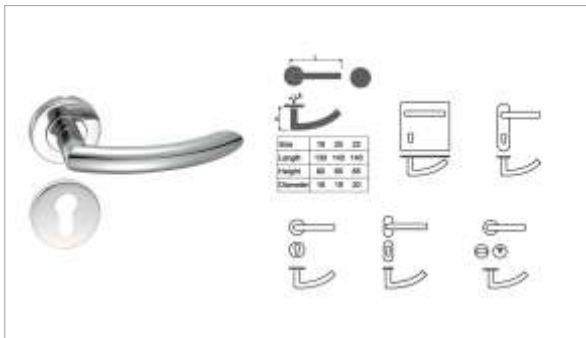

JTH112

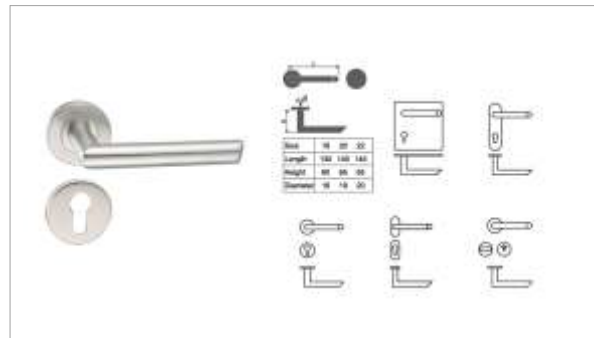

JTH113

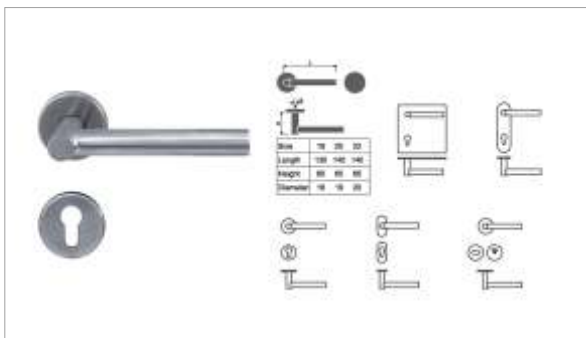

JTH114

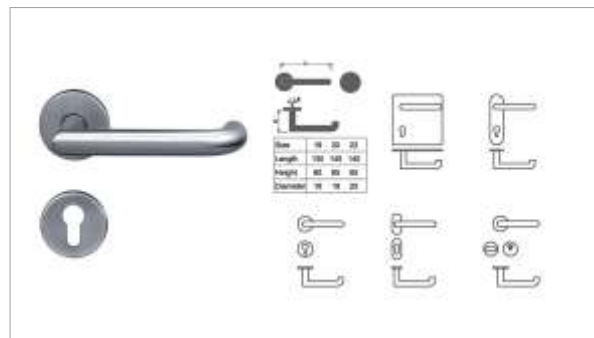

JTH115

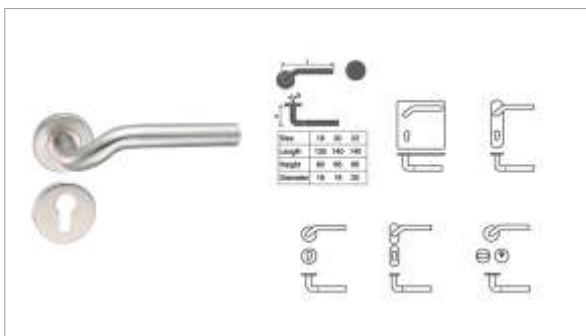

JTH116



JTH117



JTH118



JTH119

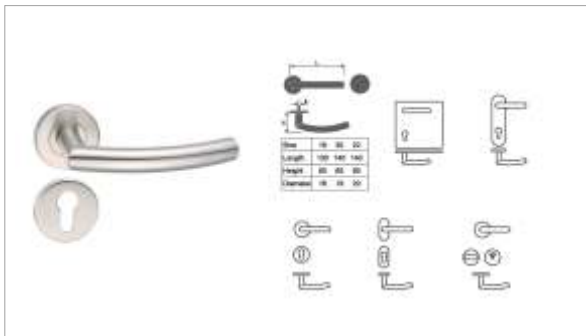

JTH120

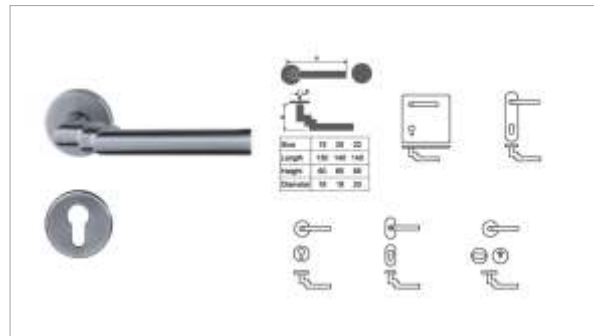

JTH121



JTH122

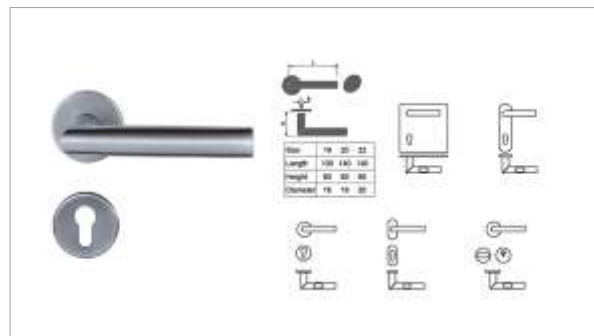

JTH123

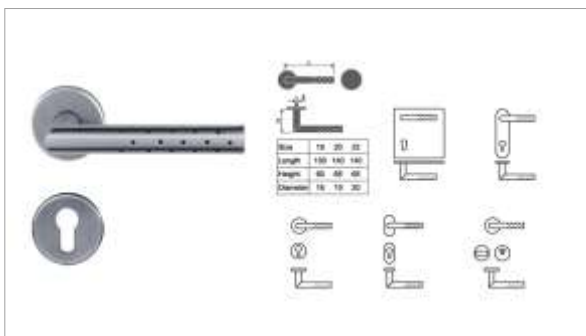

JTH124

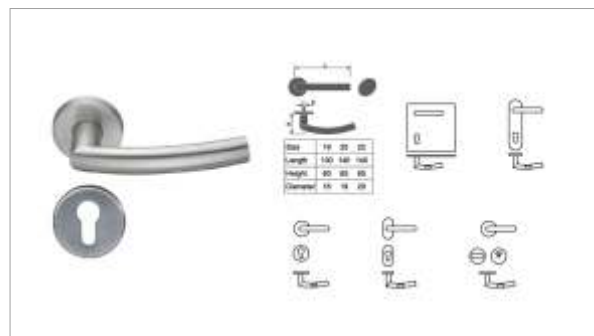

JTH101L



JTH102L

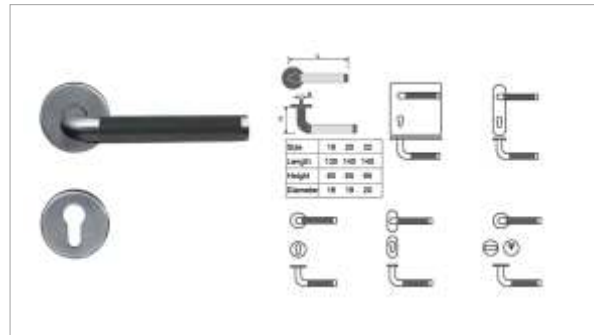

JTH104L

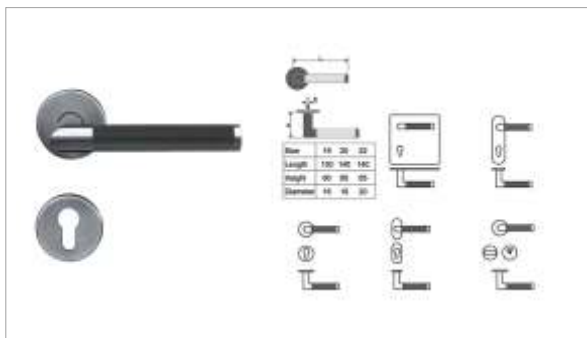

JTH128

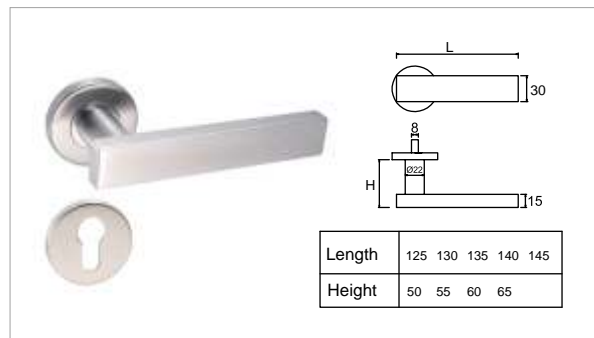

JTH129

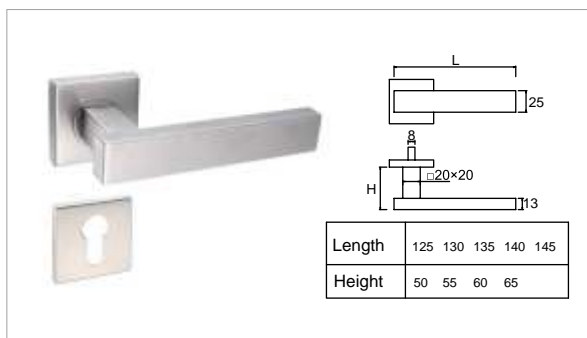

JTH130

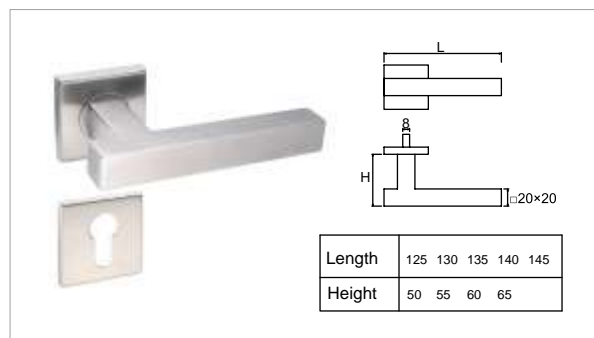

JTH131

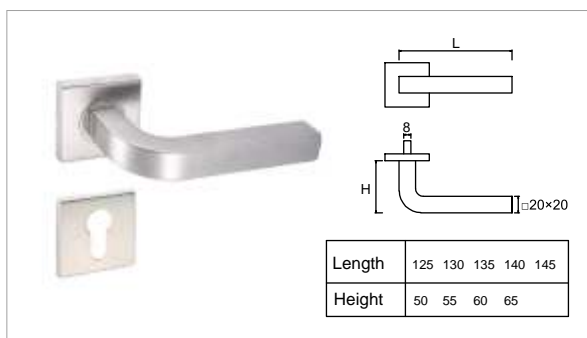

JTH132

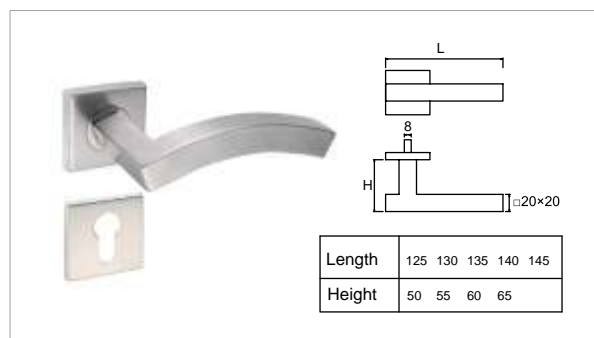

JTH133

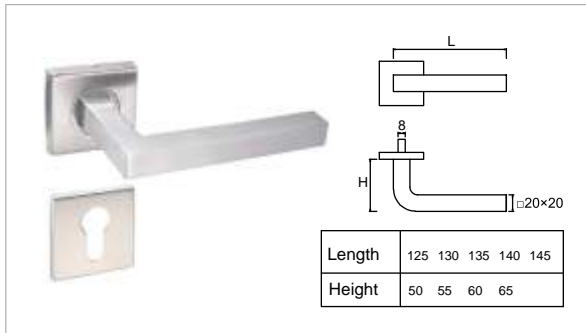

JTH134

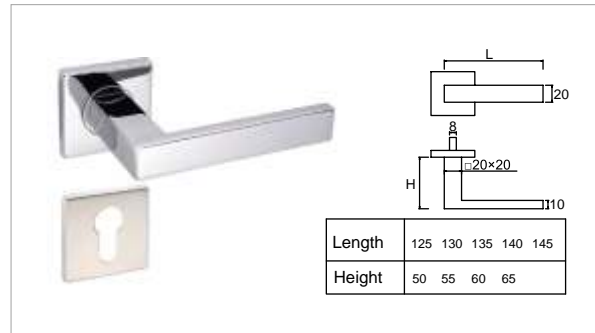

JTH135

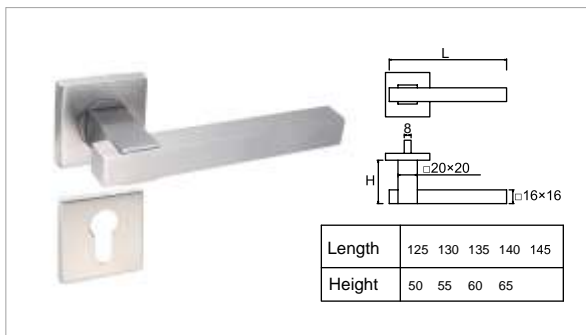

JTH136

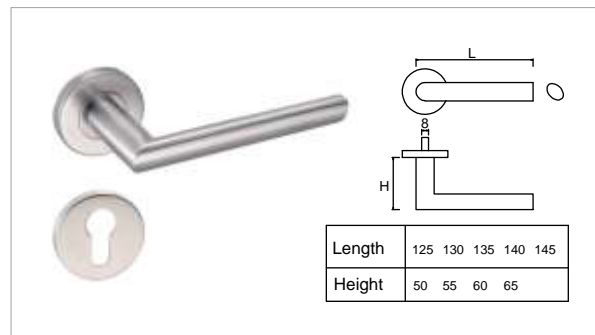

JTH137

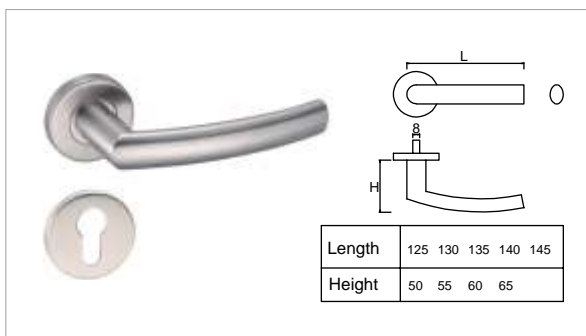

JTH138



JTH139

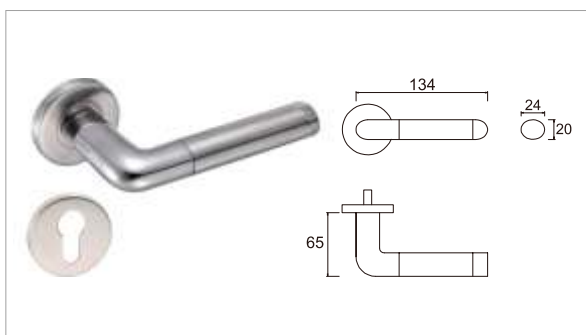

JTH140

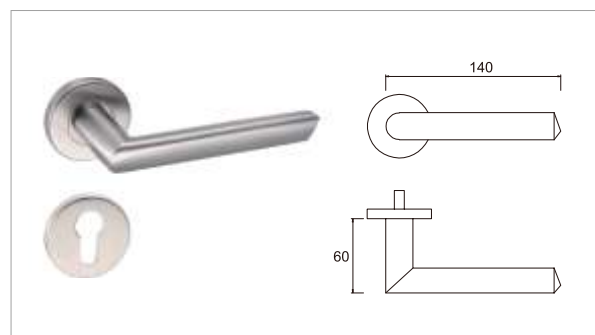

JTH141

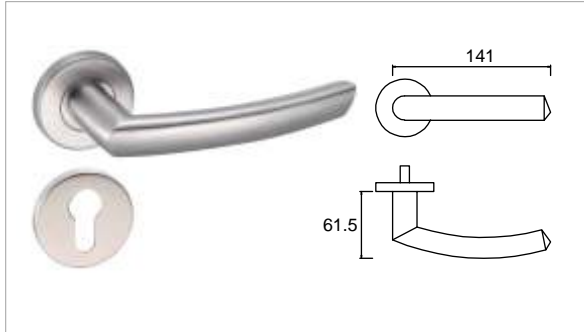

JTH199

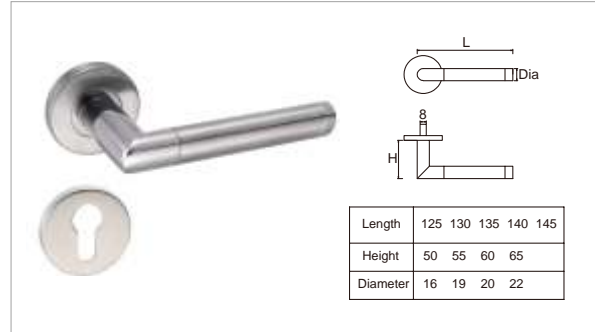

JTP300-1

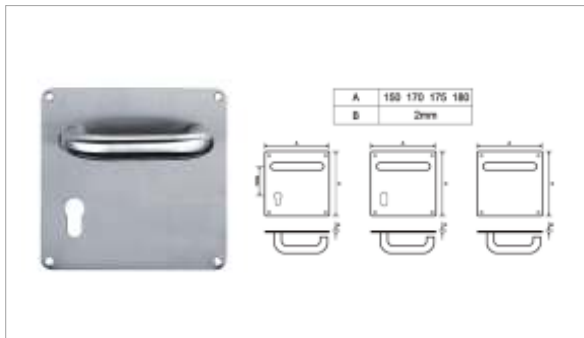

JTP300-1-C



JTP300-2-P

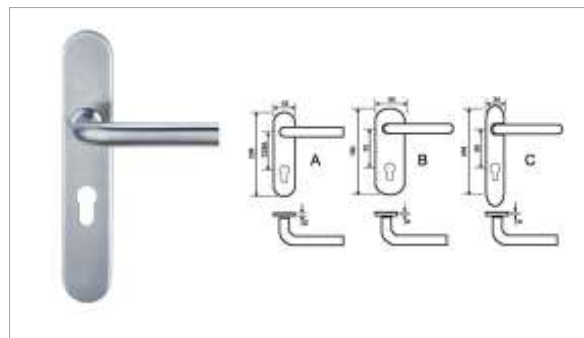

JTP300-2-O

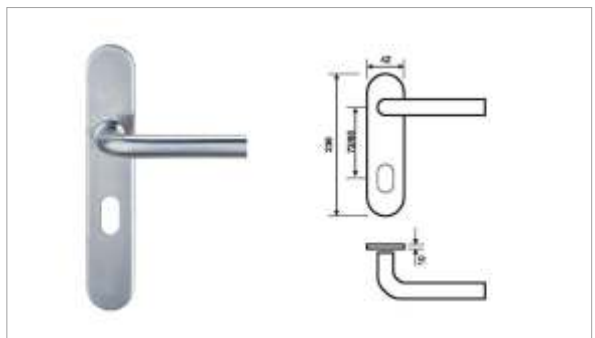

JTP300-2-C

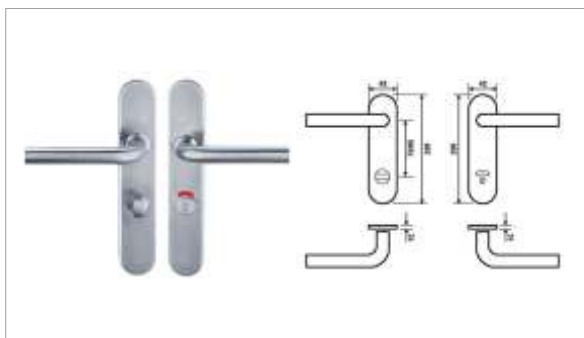

JTP300-3

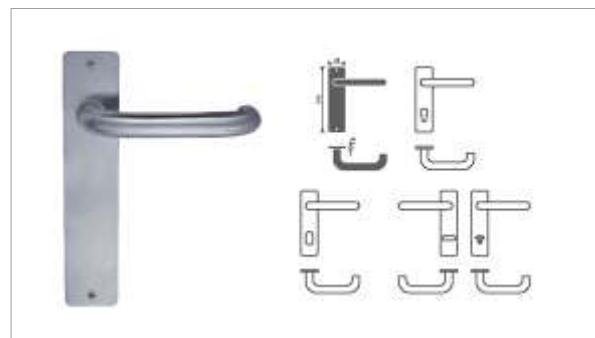

JFK004-P

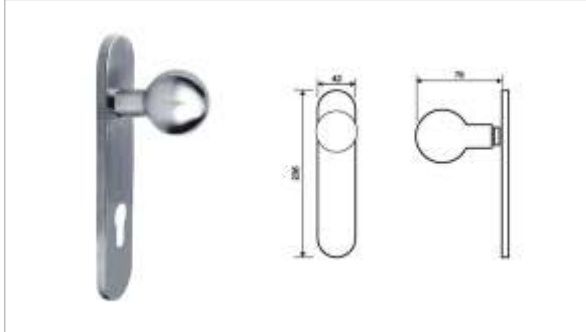

JFK005-P



JTP300-4-P

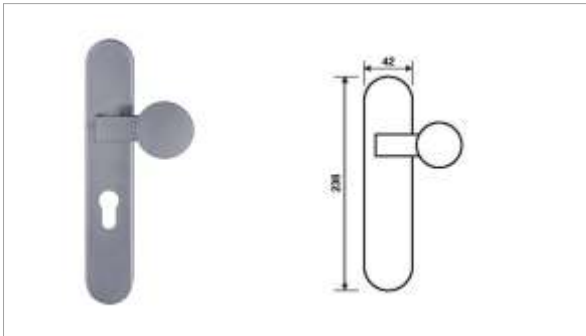

JTP300-5

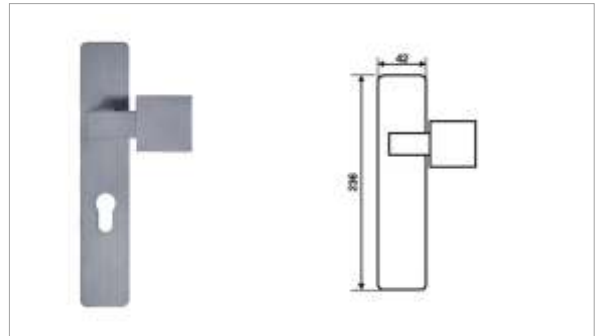

JTH201



JTH202



JLH001

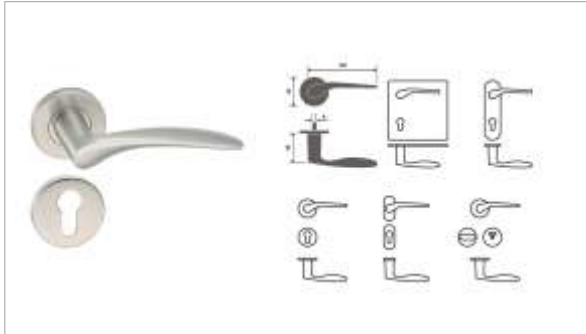

JLH002

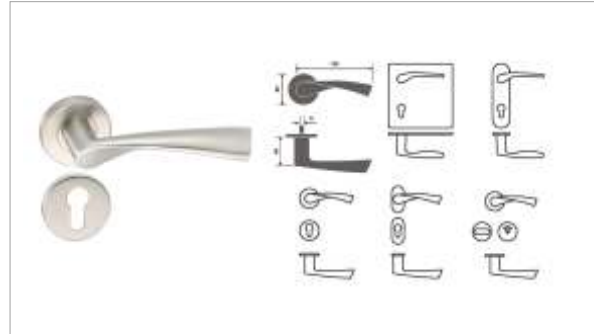

JLH003

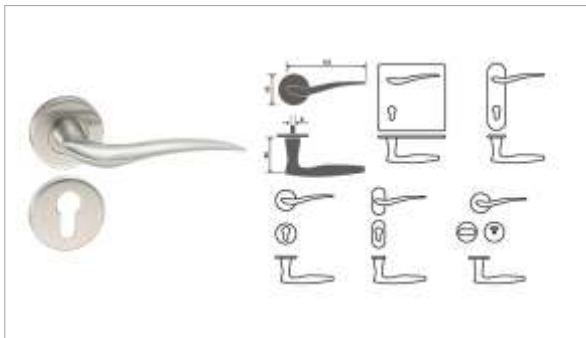

JLH004

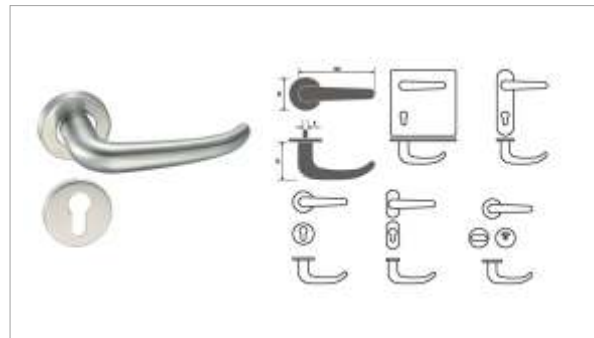

JLH005

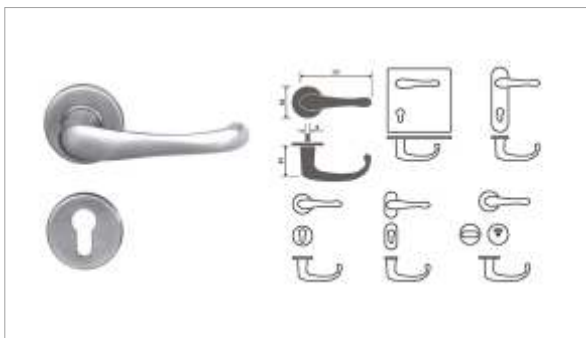

JLH006

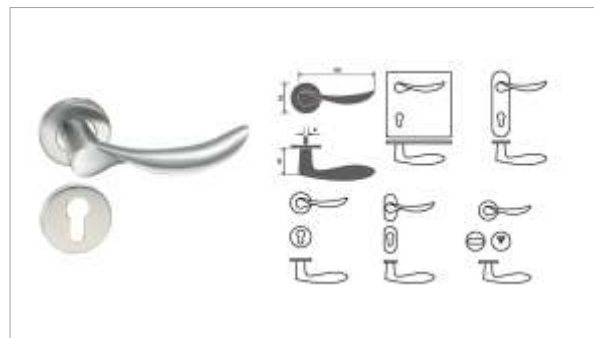

JLH007

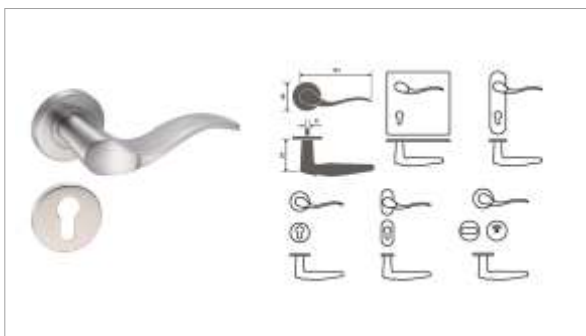

JLH008

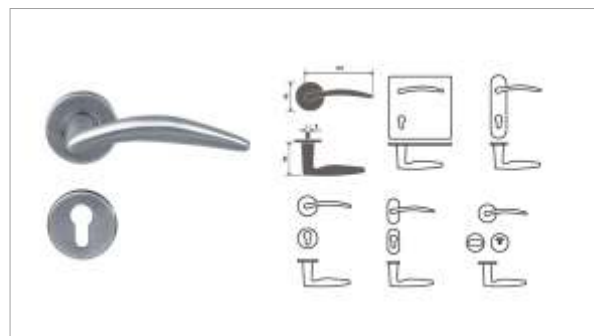

JLH009

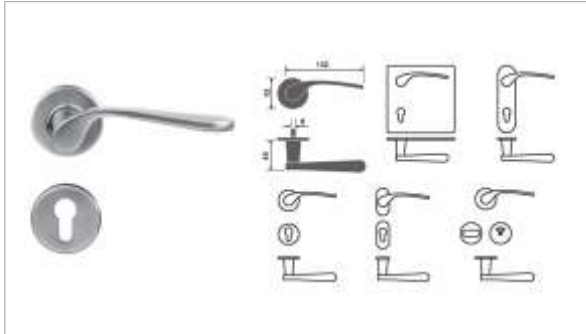

JLH010

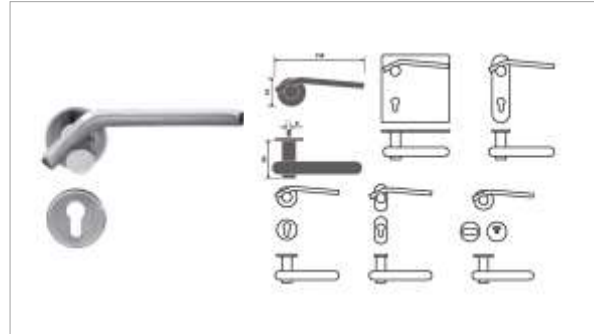

JLH011

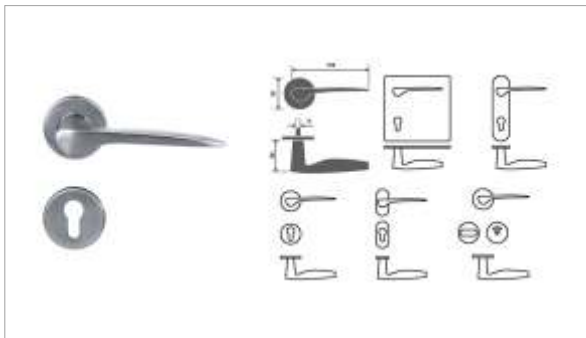

JLH012

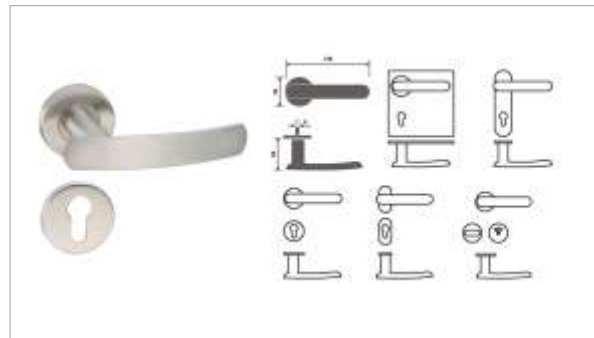

JLH013

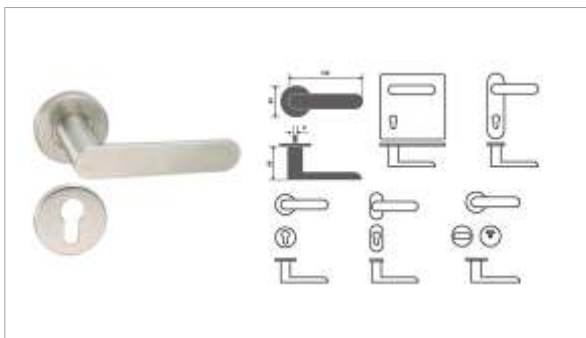

JLH014

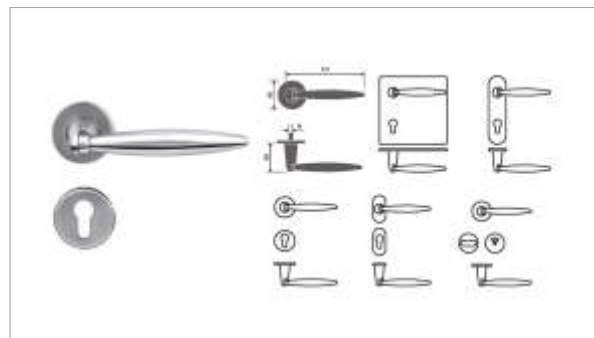

JLH015

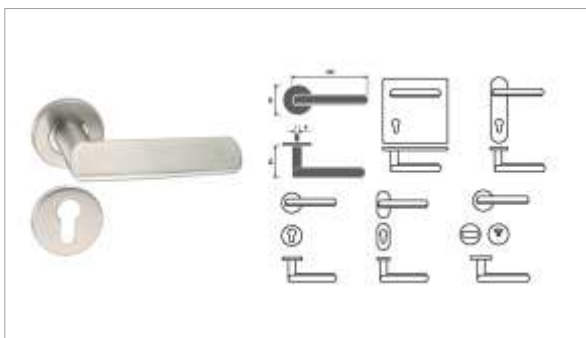

JLH016



JLH017

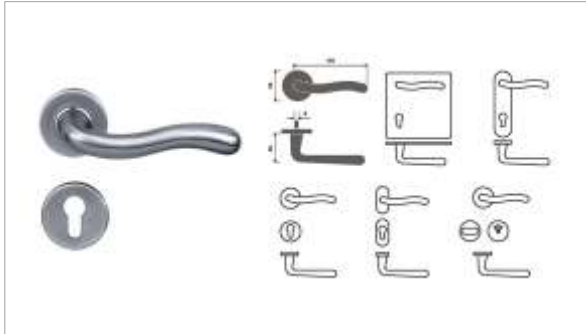

JLH018



JLH019

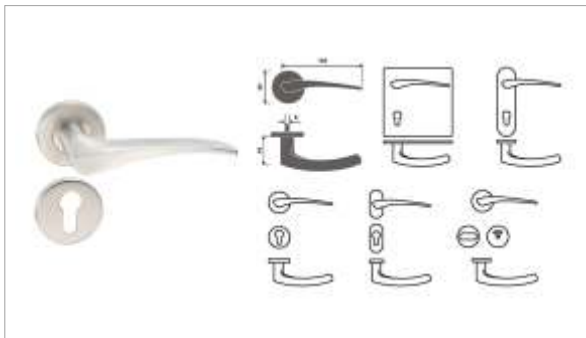

JLH020



JLH021



JLH022

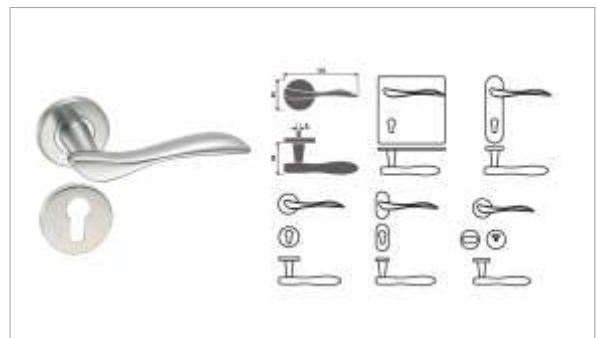

JLH023

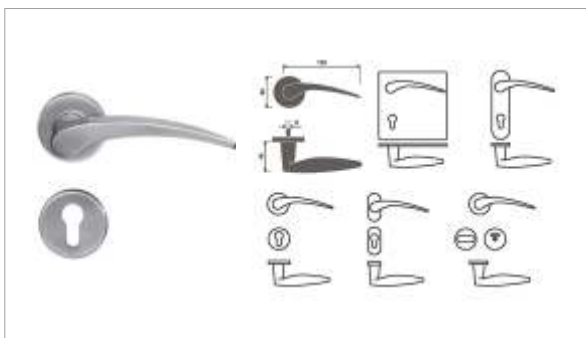

JLH024

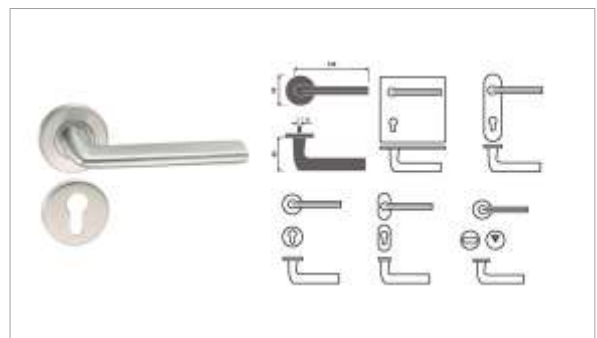

JLH025

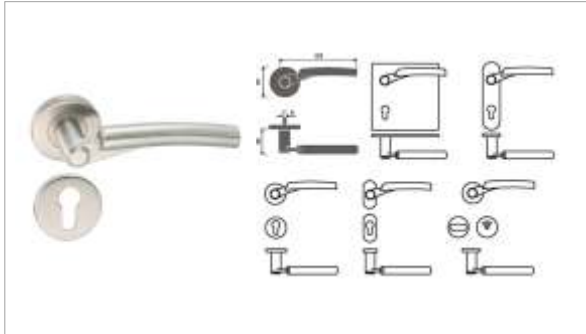

JLH026

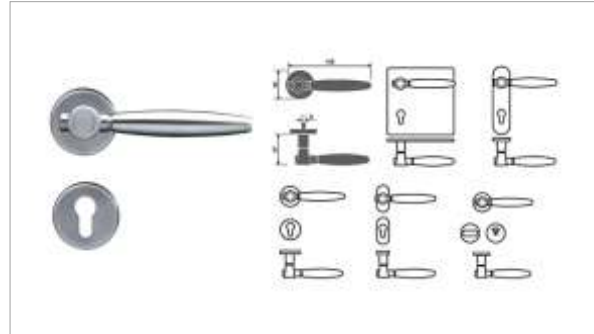

JLH027

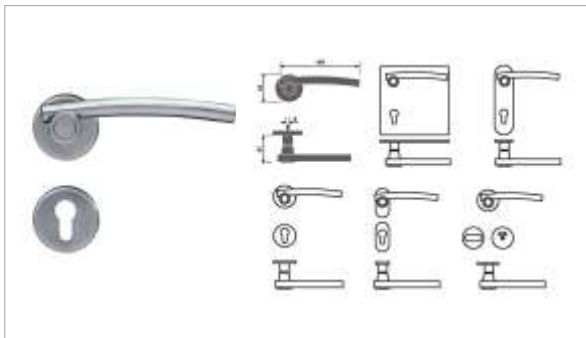

JLH028

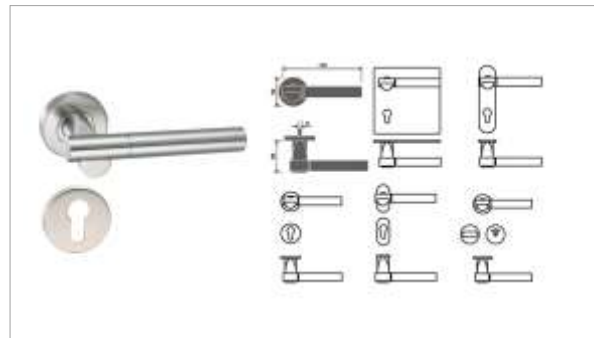

JLH029

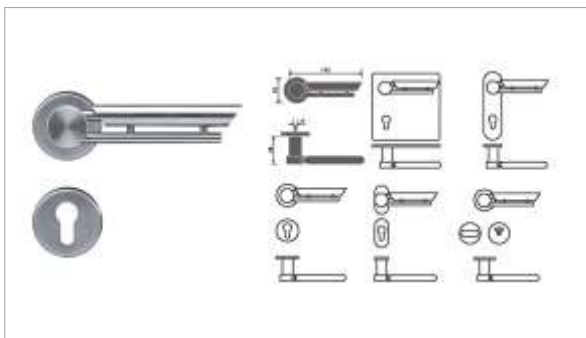

JLH030

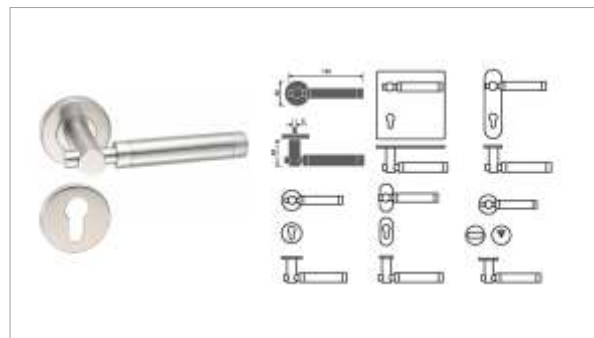

JLH031

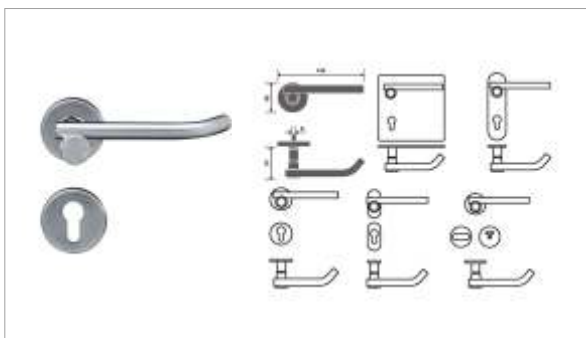

JLH032

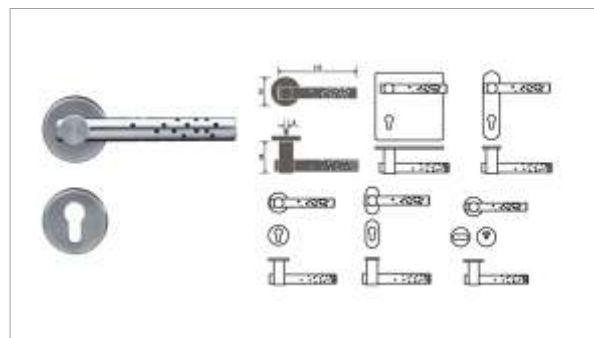

JLH033

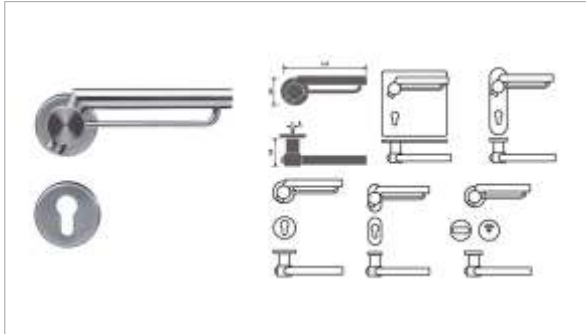

JLH034

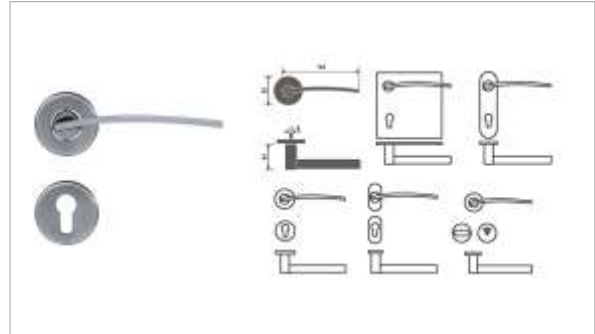

JLH035

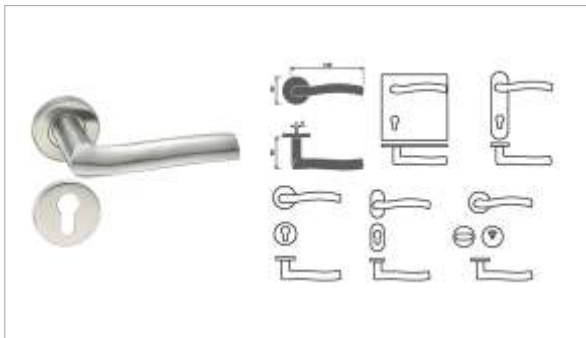

JLH036



JLH037

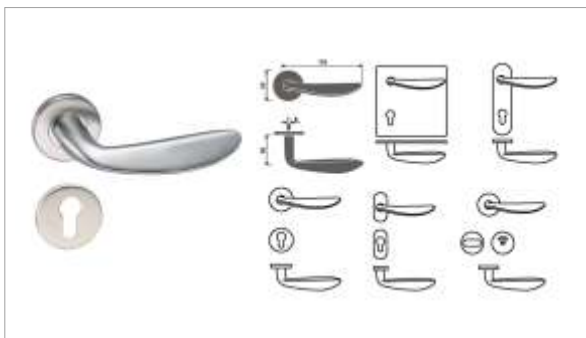

JLH038

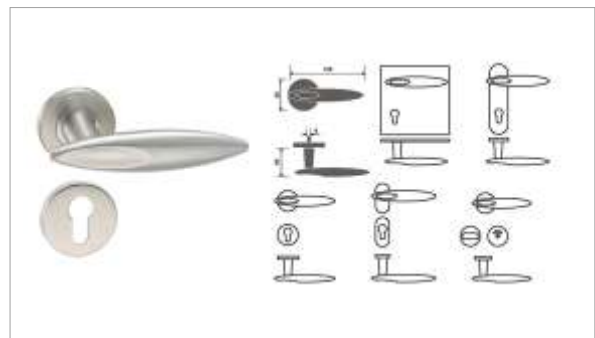

JLH039

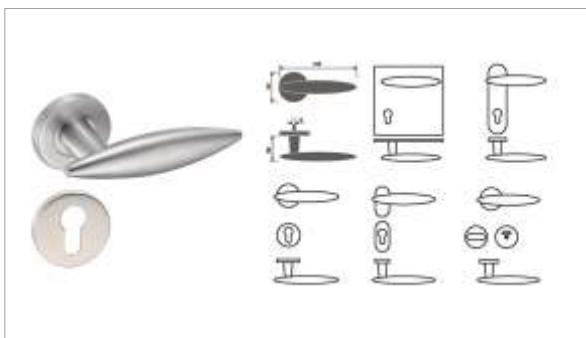

JLH040

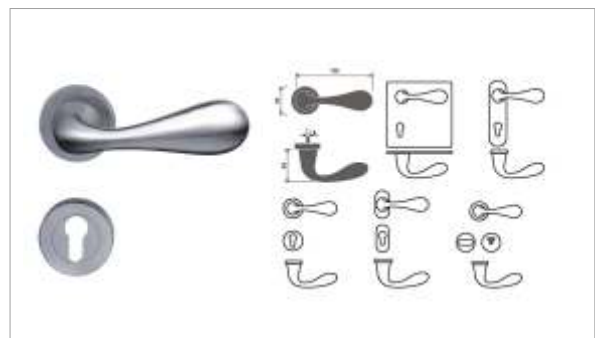

JLH041

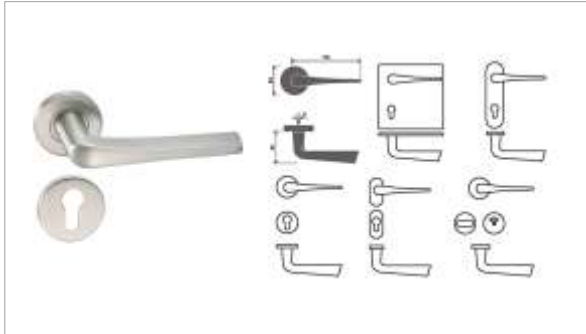

JLH042

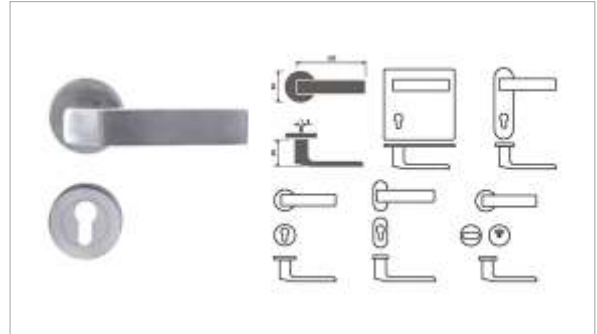

JLH043

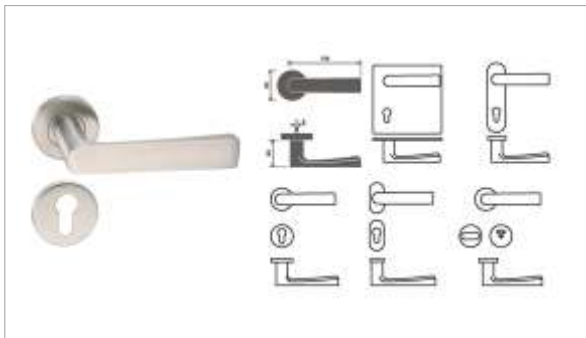

JLH044

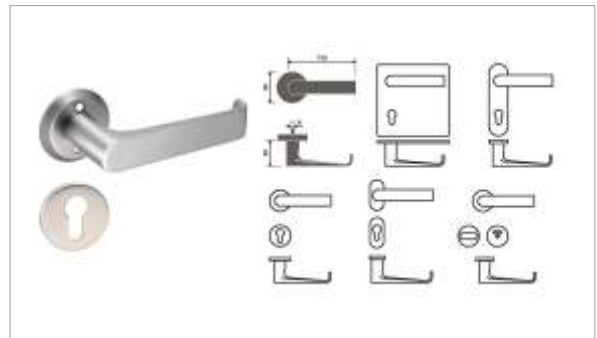

JLH045

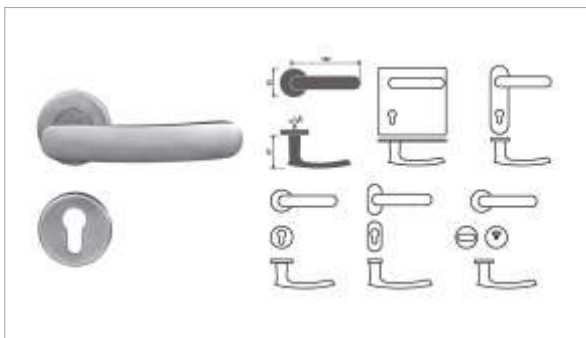

JLH046

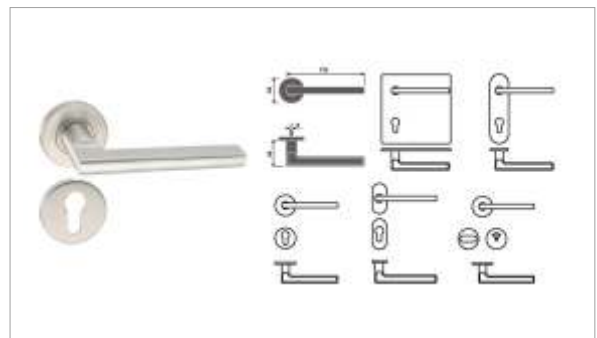

JLH047

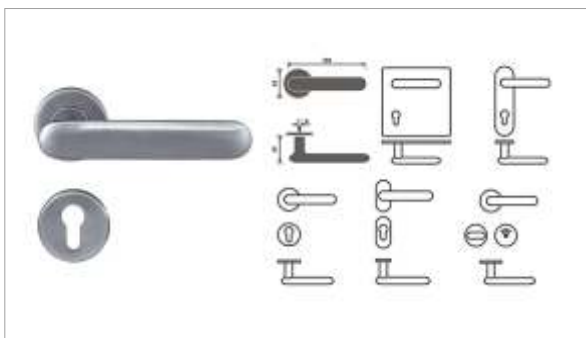

JLH048

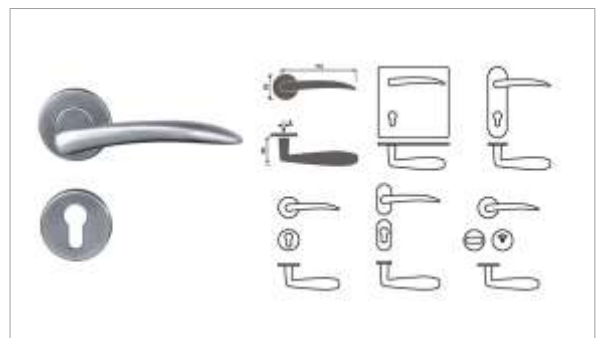

JLH049

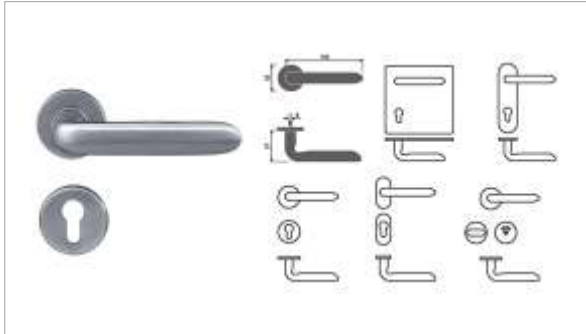

JLH050

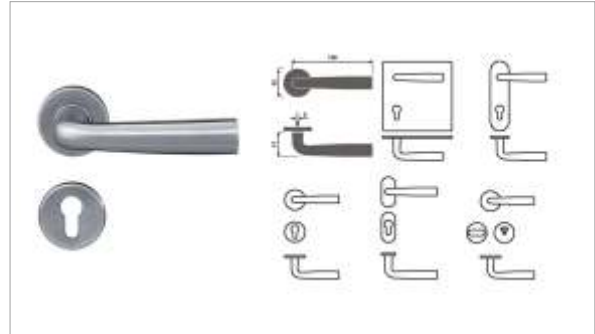

JLH051

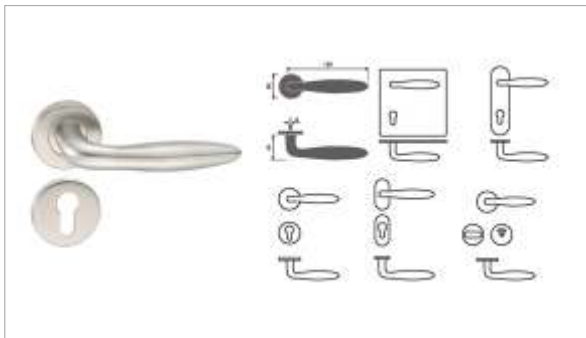

JLH052

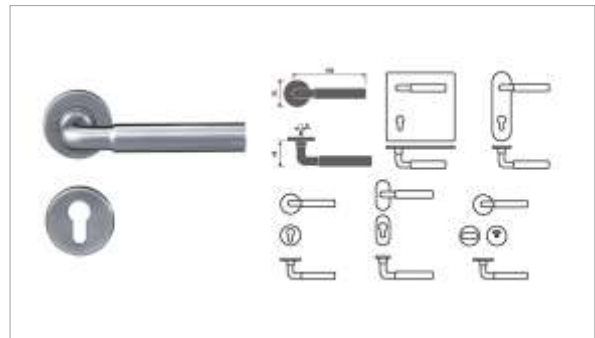

JLH053

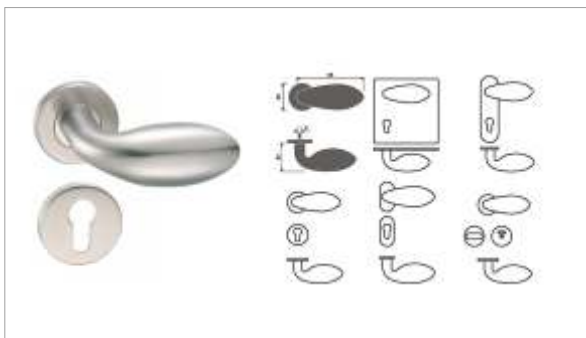

JLH054



JLH055



JLH056

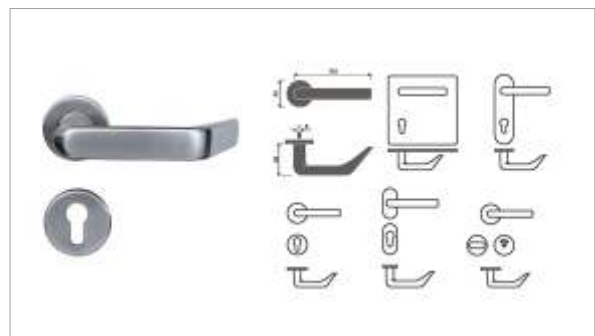

JLH057

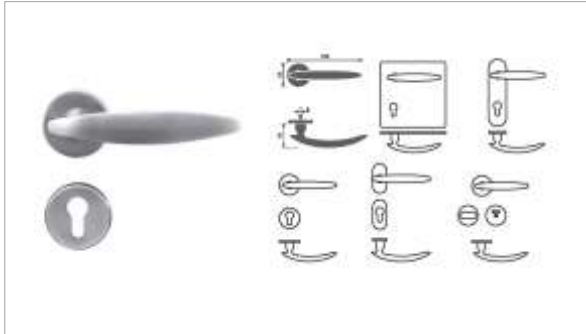

JLH058

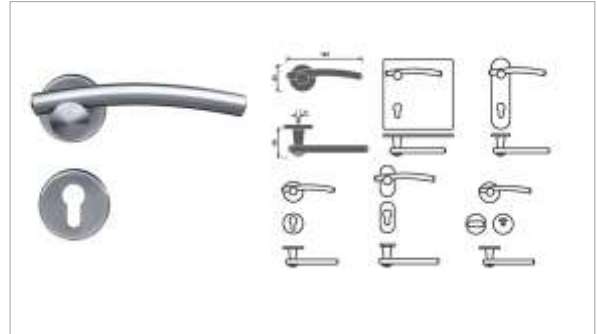

JLH059

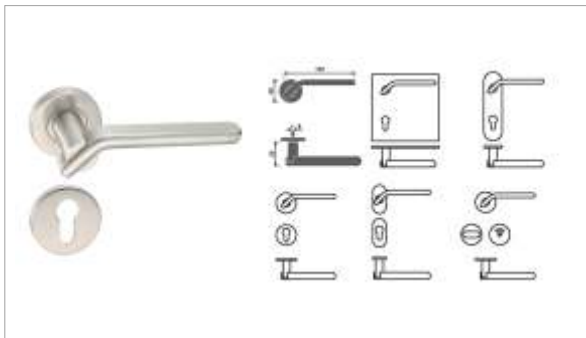

JLH060

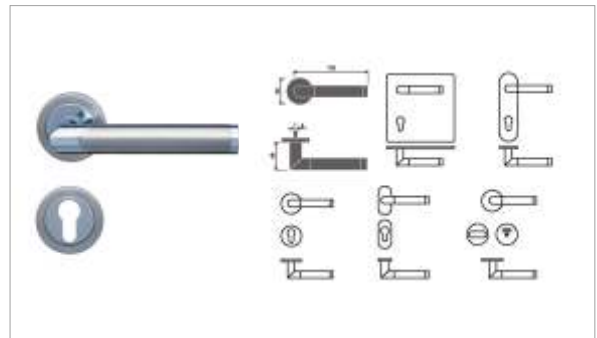

JLH061

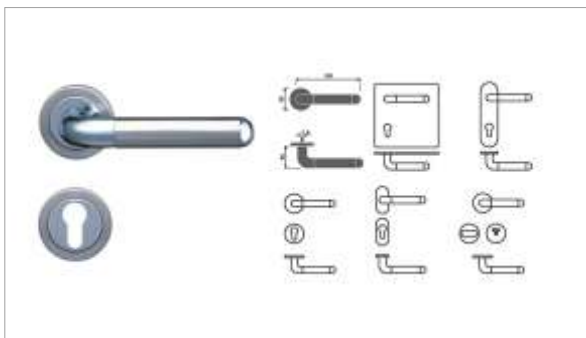

JLH062

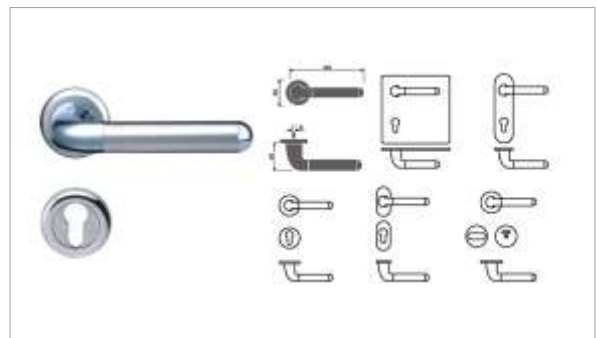

JLH063

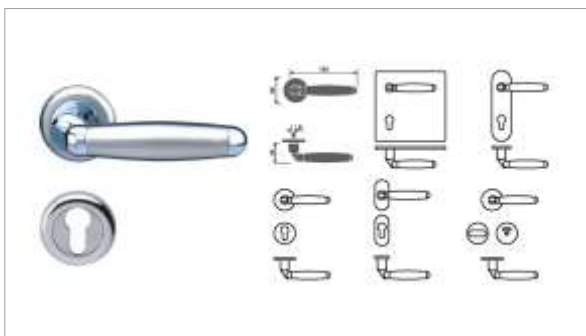

JLH064

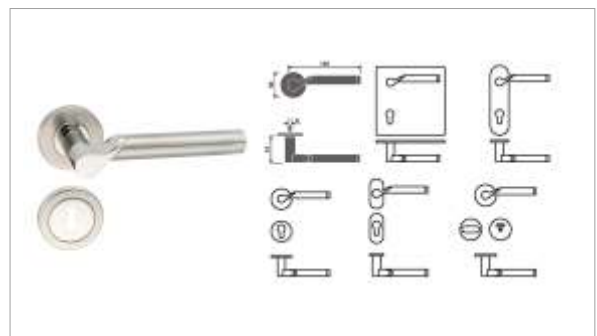

JLH066

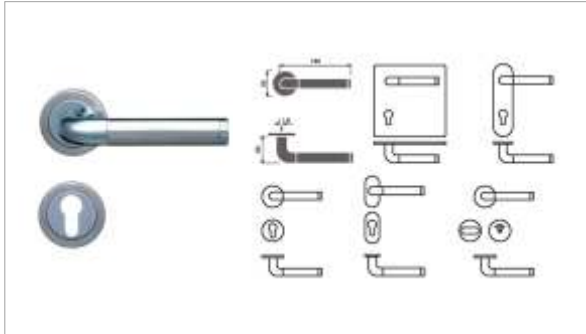

JLH067

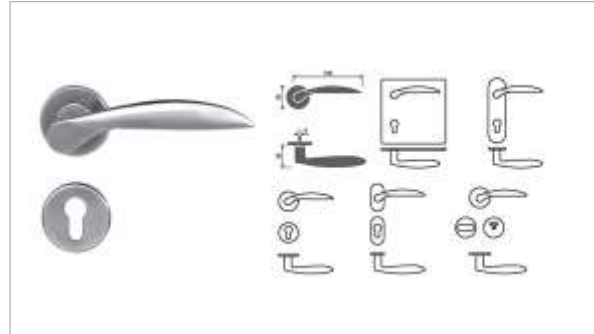

JLH068

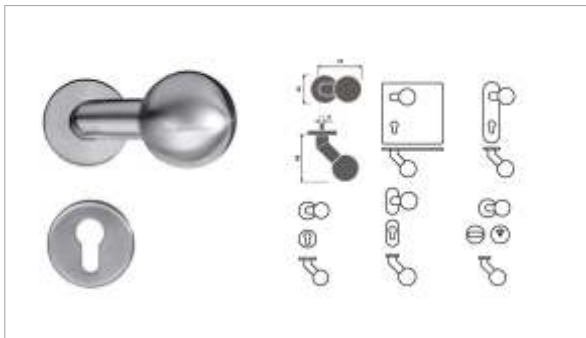

JLH169

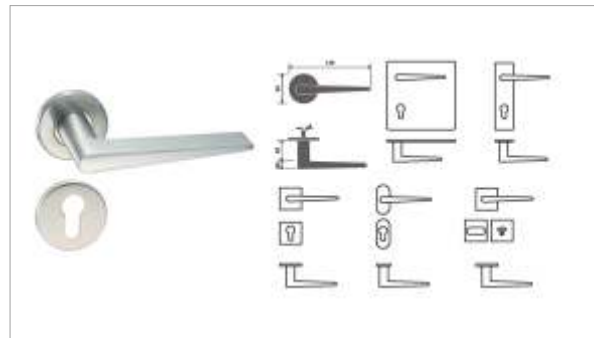

JLH070



JLH071



JLH072



JLH073

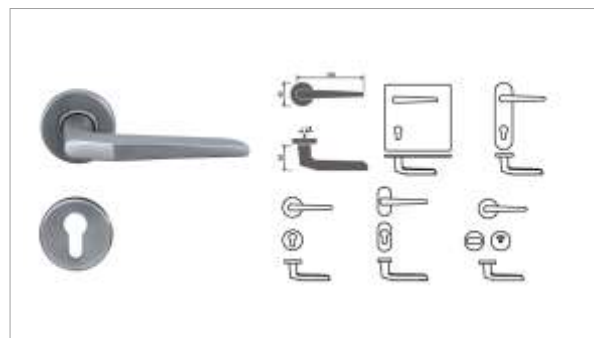

JLH074

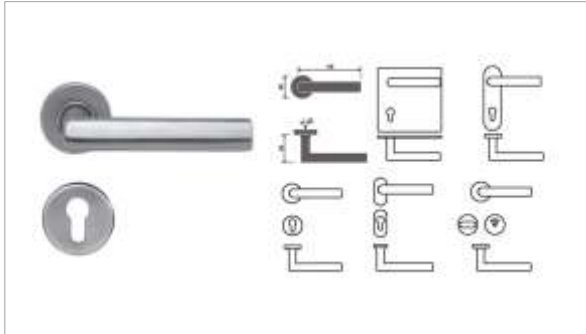

JLH076

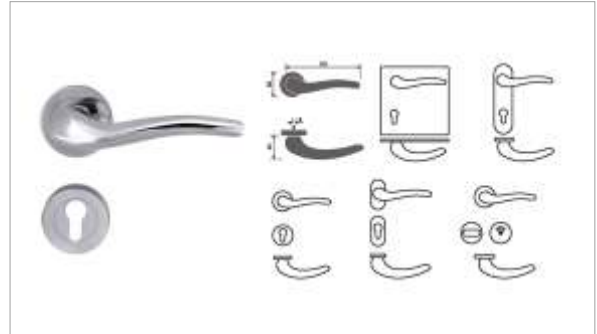

JLH077

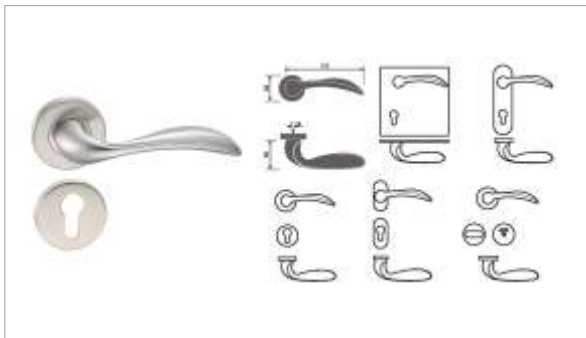

JLH078



JLH079



JLH080

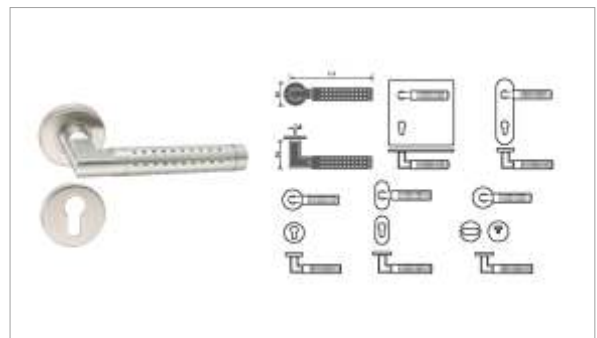

JLH081



JLH082

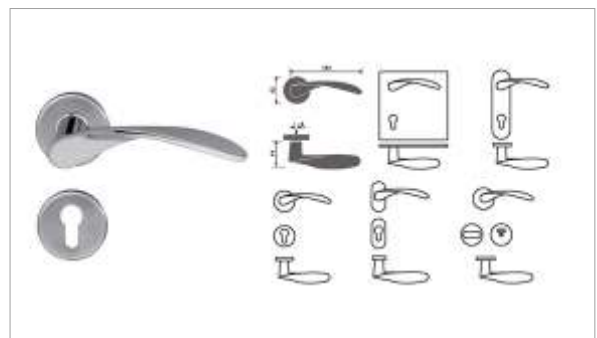

JLH083



JLH084

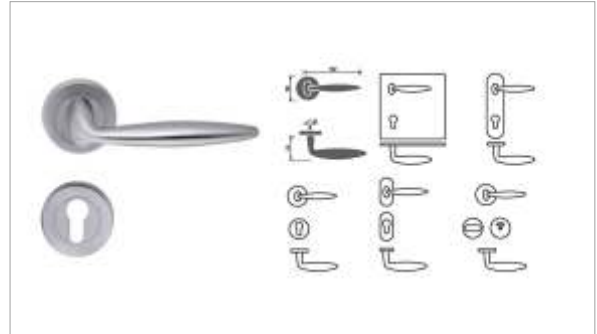

JLH085

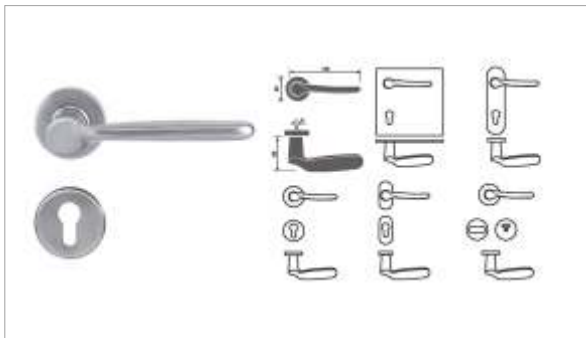

JLH086

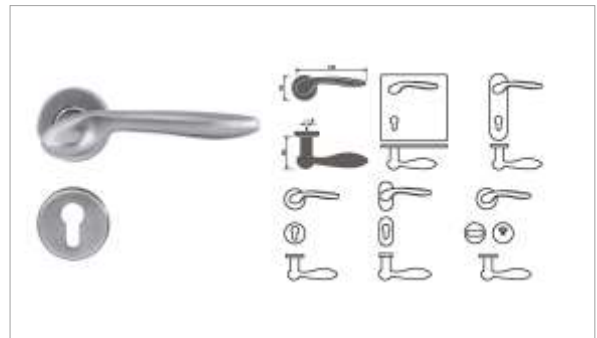

JLH087



JLH088

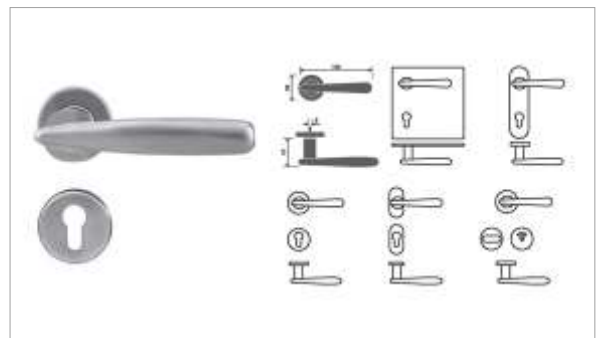

JLH089



JLH090

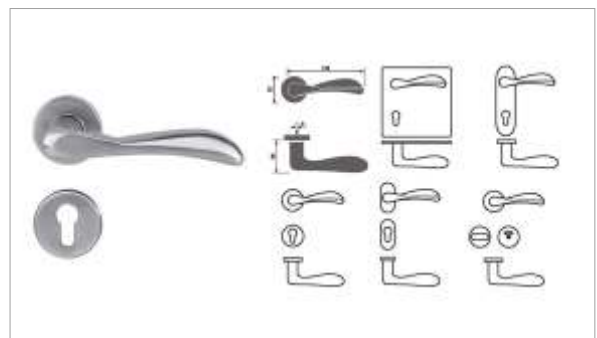

JLH091



JLH092



JLH093

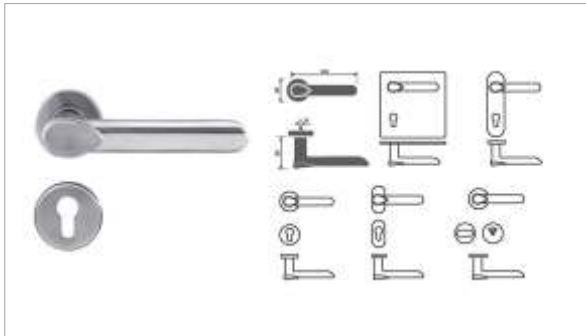

JLH094

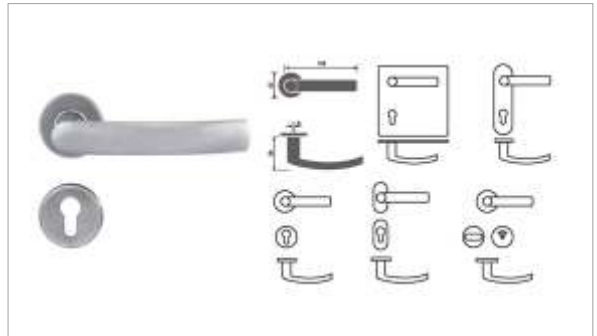

JLH095

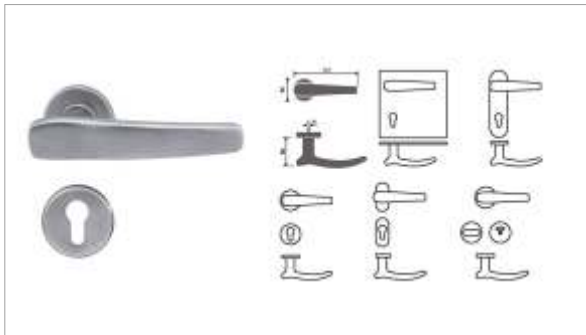

JLH096



JLH097

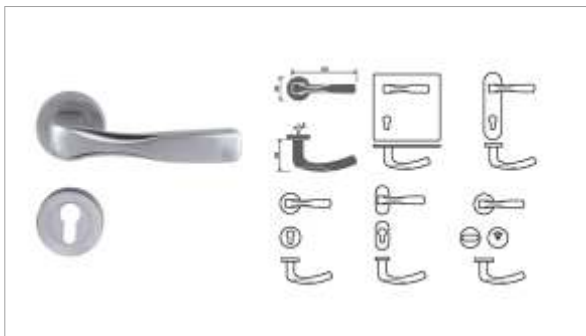

JLH098



JLH099



JLH100

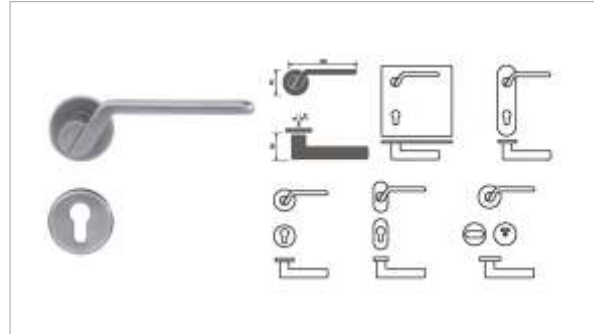

JLH101

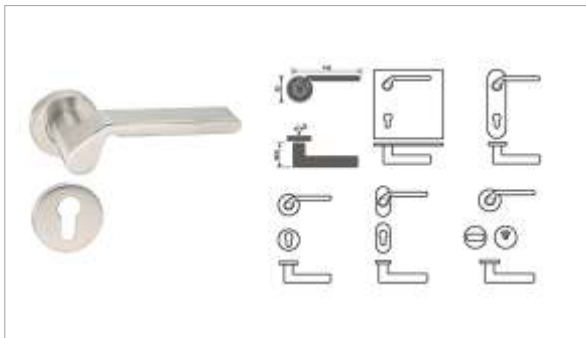

JLH102



JLH103

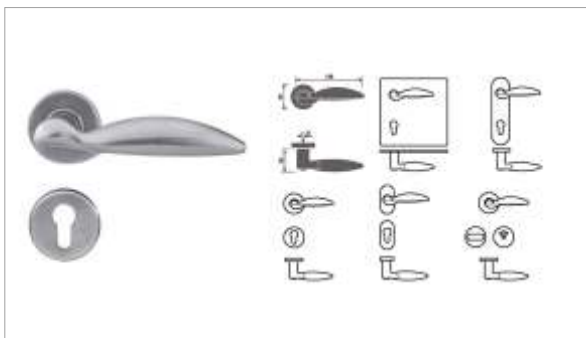

JLH104



JLH105

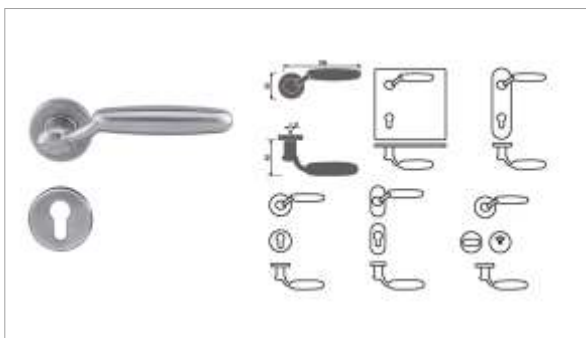

JLH107

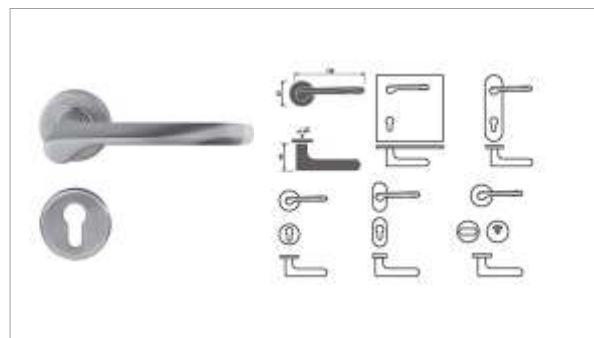

JLH108

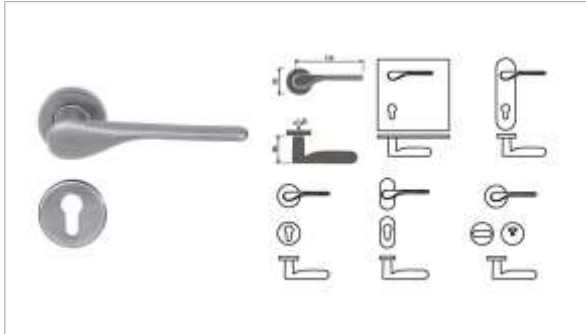

JLH109



JLH110

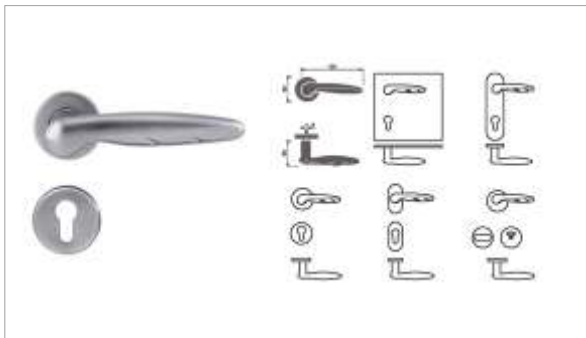

JLH111

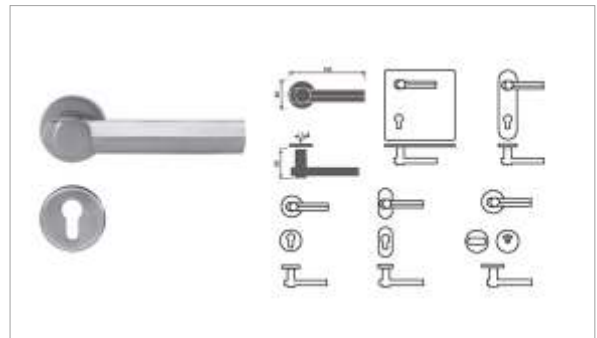

JLH112

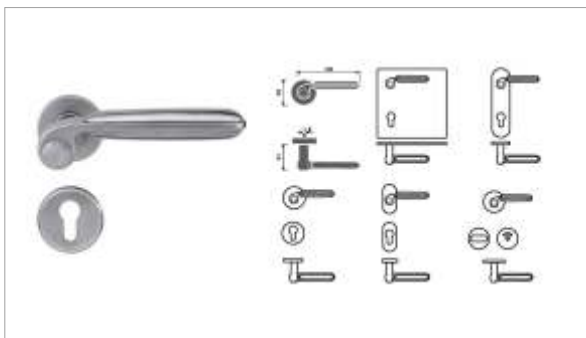

JLH113

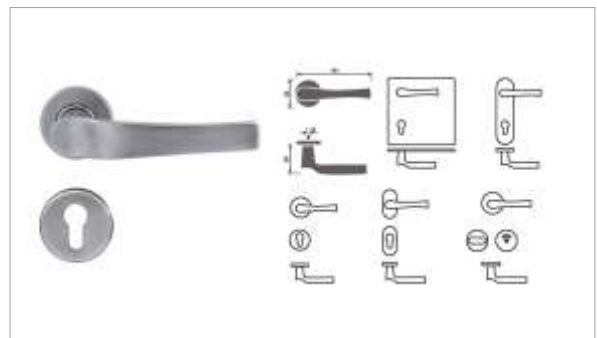

JLH114

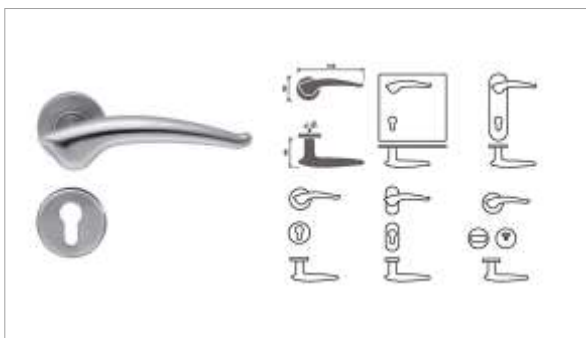

JLH115

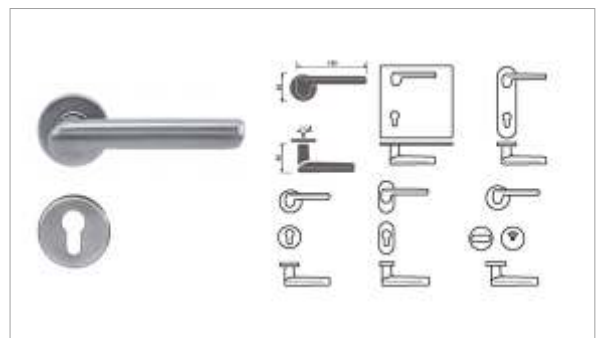

JLH117

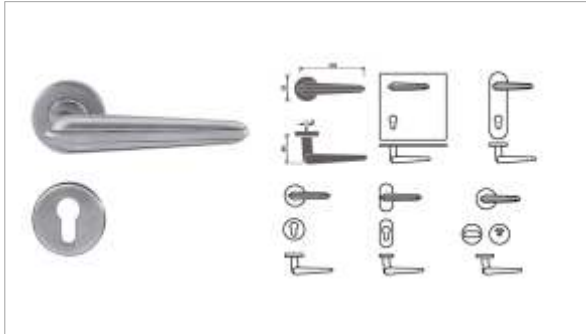

JLH119

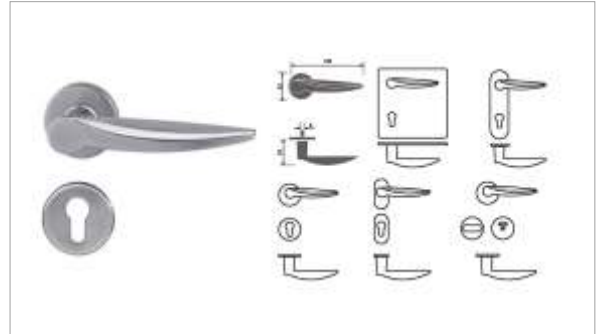

JLH120

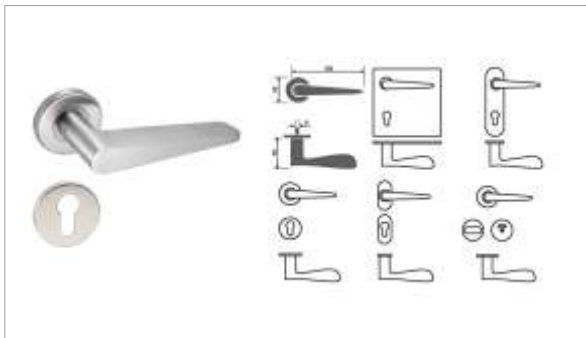

JLH121

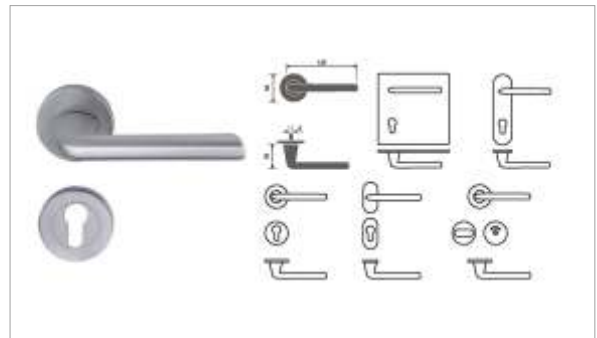

JLH122

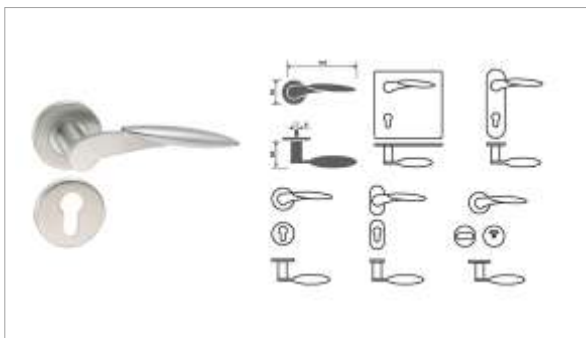

JLH123

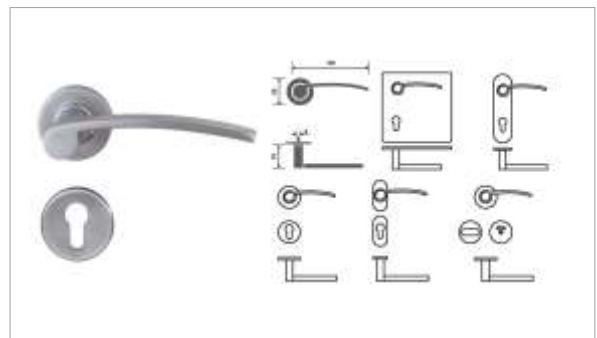

JLH124

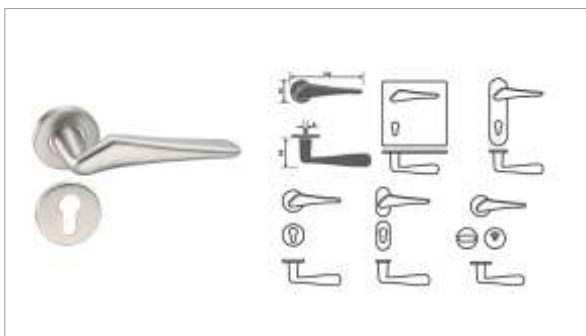

JLH125

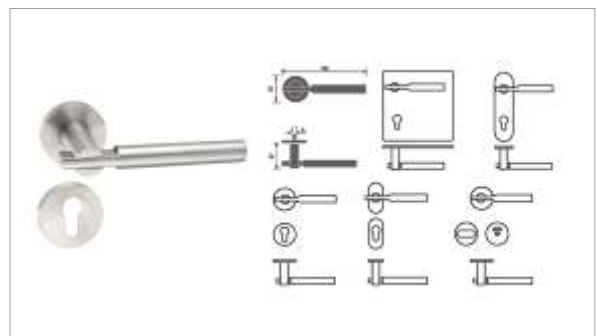

JLH126

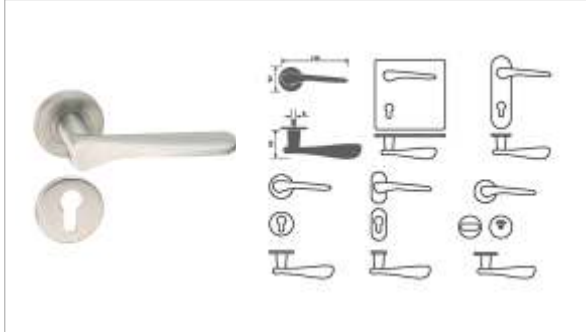

JLH127



JLH128

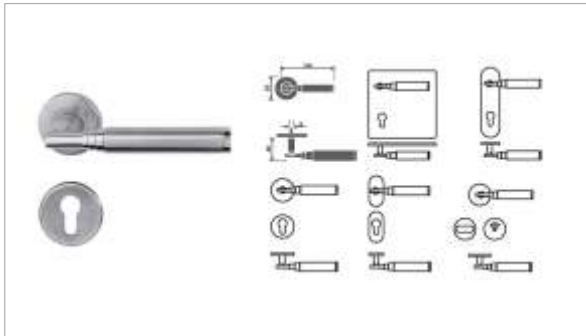

JLH129

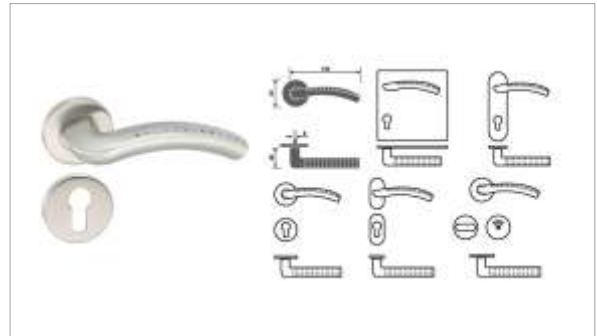

JLH130

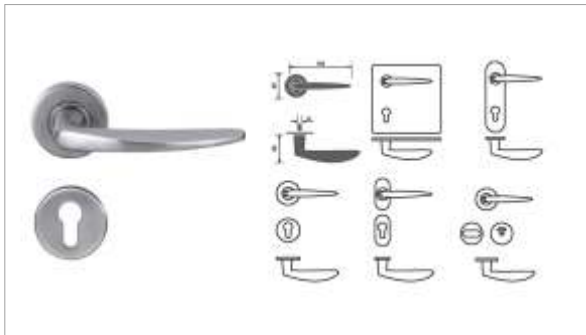

JLH131

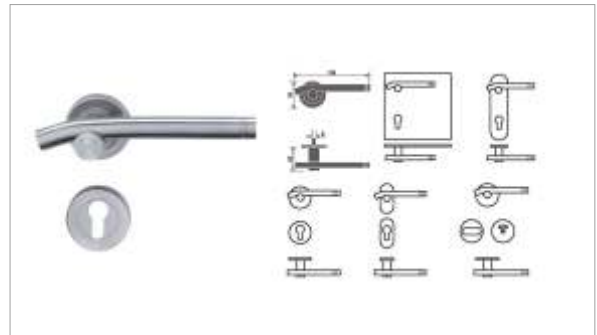

JLH132

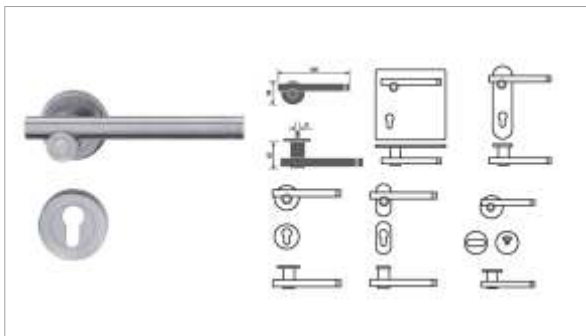

JLH133

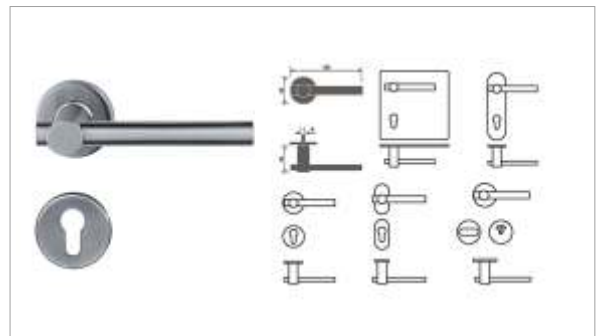

JLH134

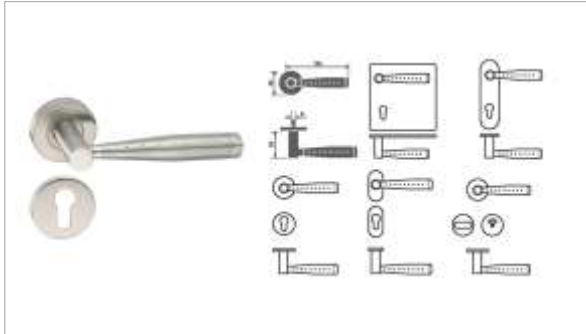

JLH135

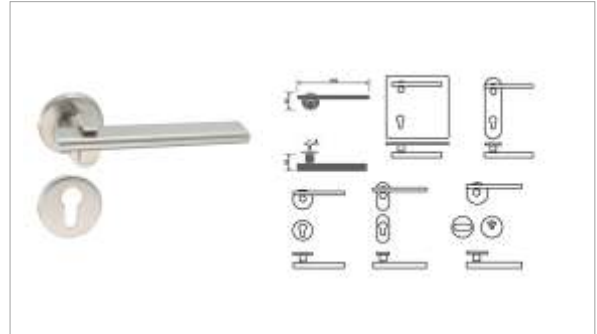

JLH136

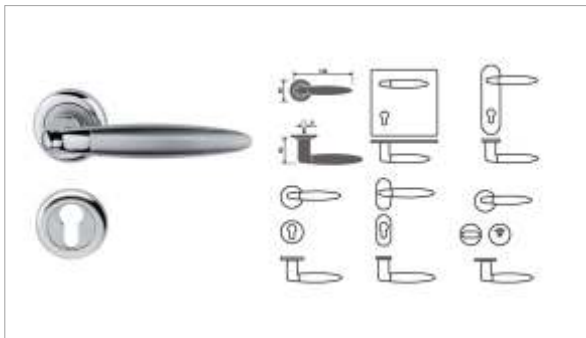

JLH137

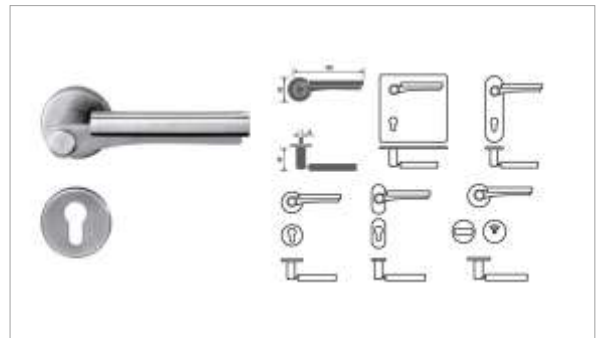

JLH138

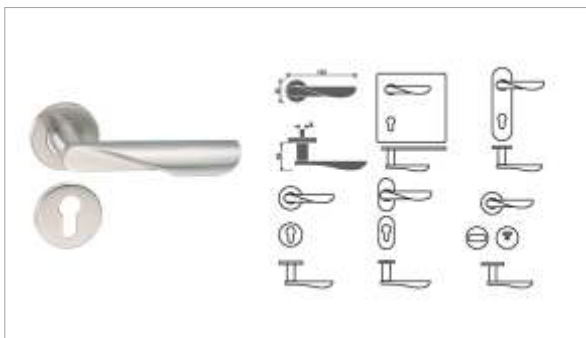

JLH140

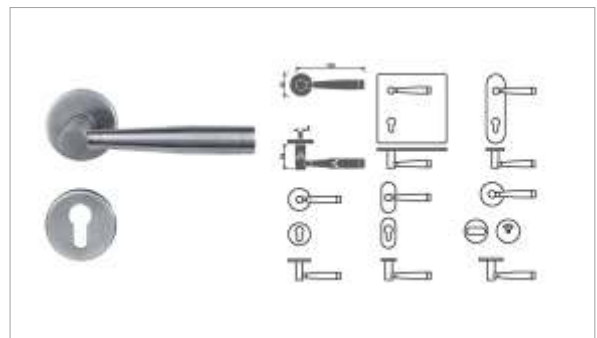

JLH141

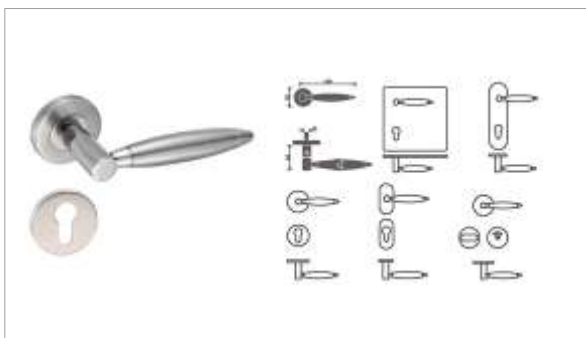

JLH142

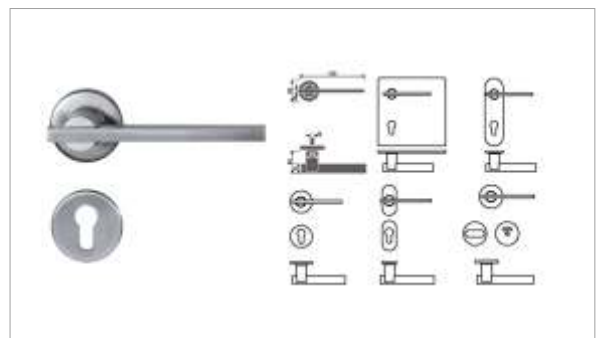

JLH143

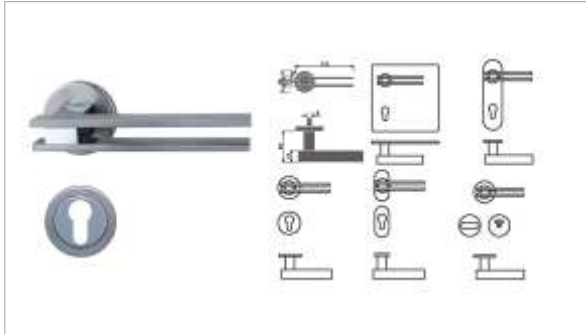

JLH144

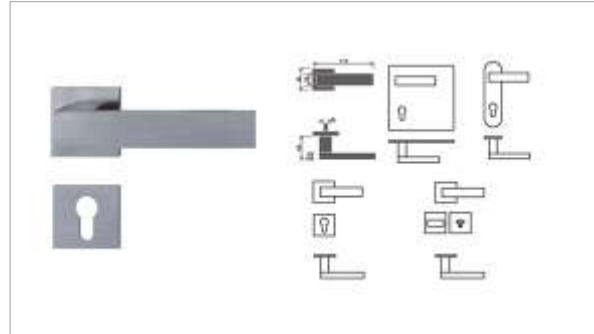

JLH145

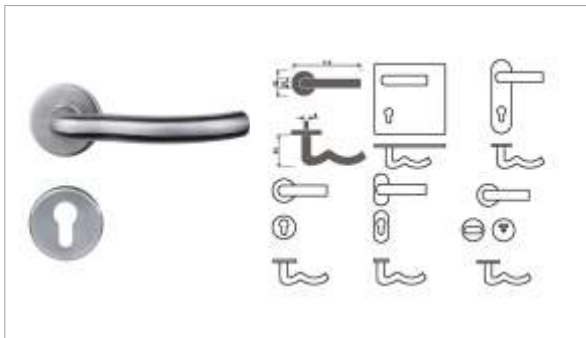

JLH146

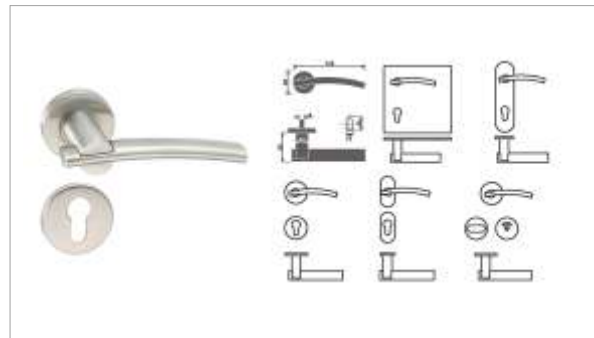

JLH147

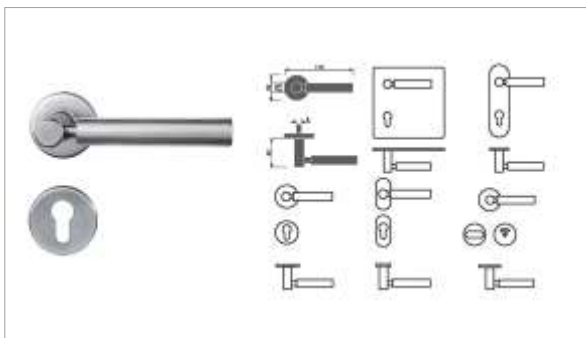

JLH148



JLH149

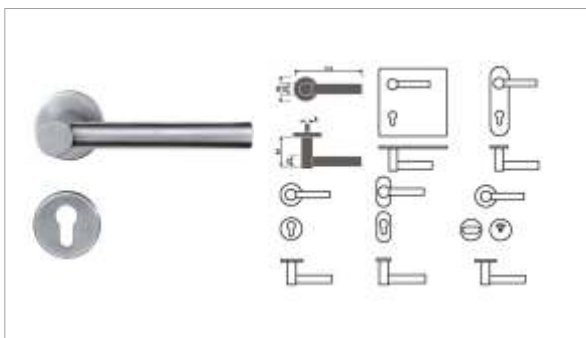

JLH150

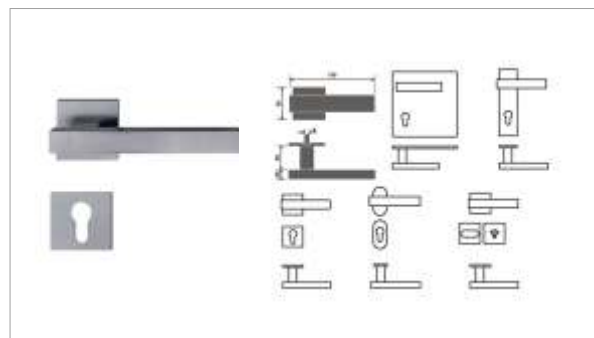

JLH159

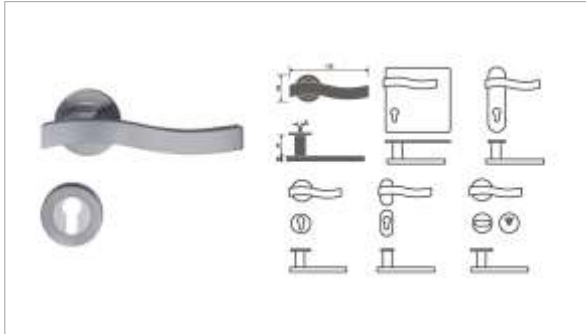

JLH160

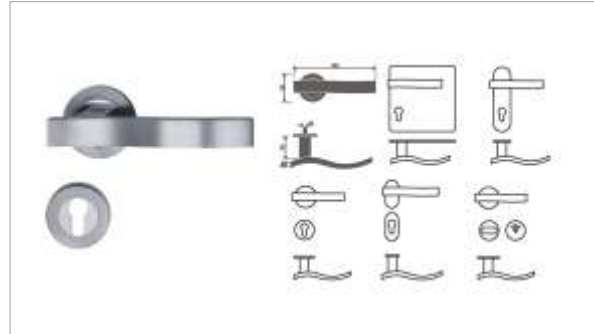

JLH161

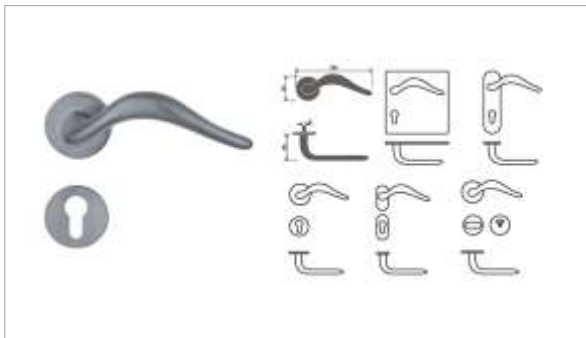

JLH162

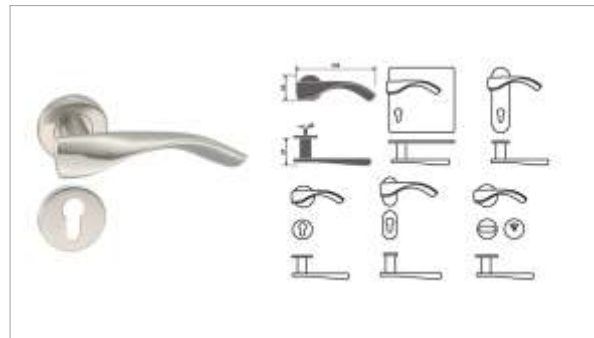

JLH163



JLH164

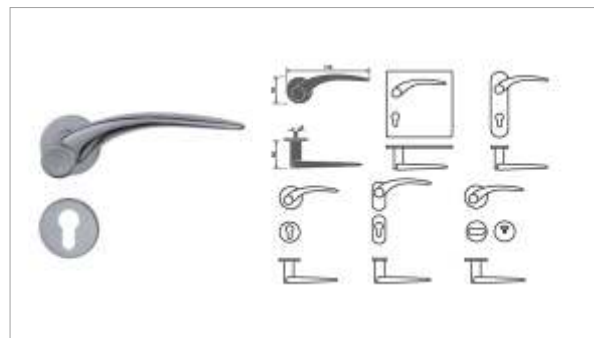

JLH165

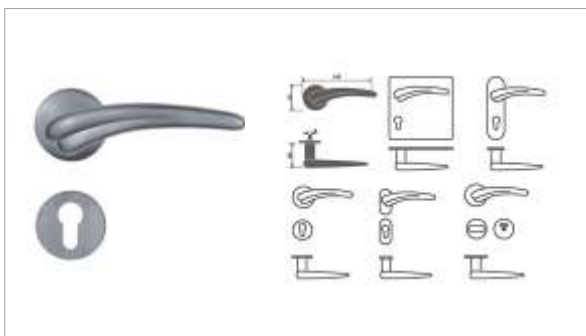

JLH166



JLH167

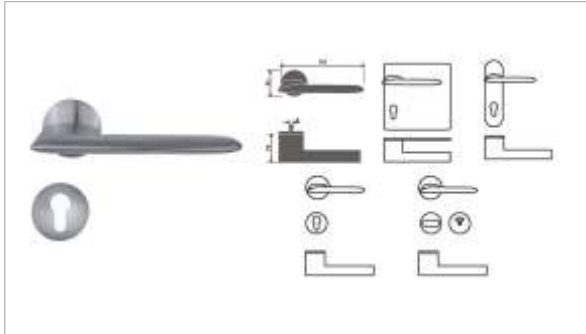

JLH168

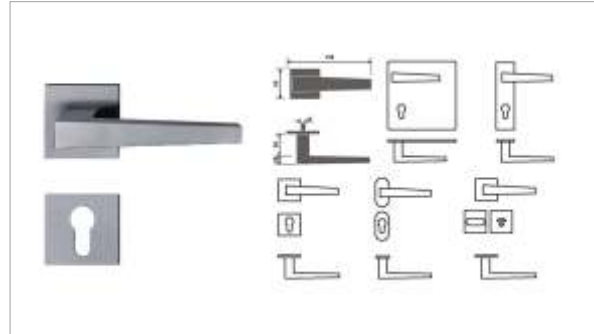

JLH169

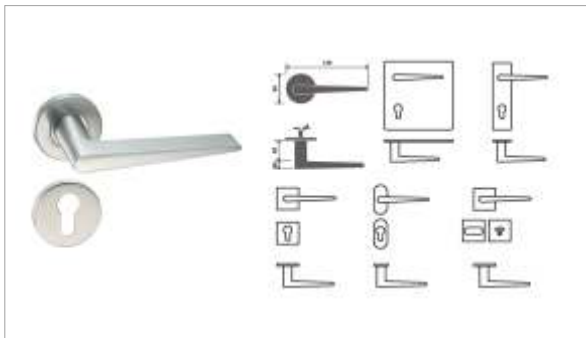

JLH170

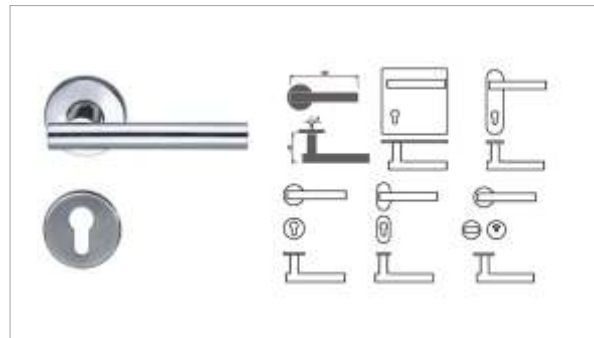

JLH171

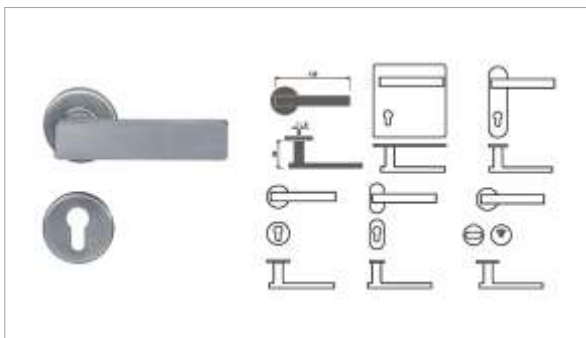

JLH172

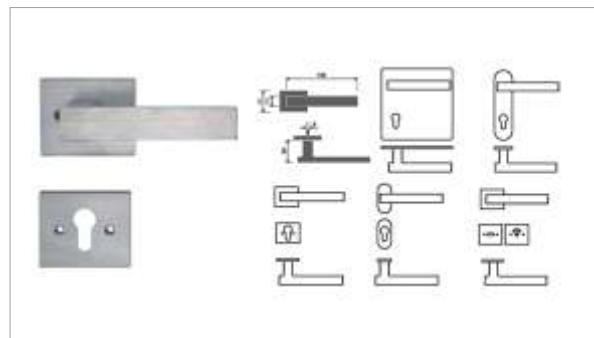

JLH173

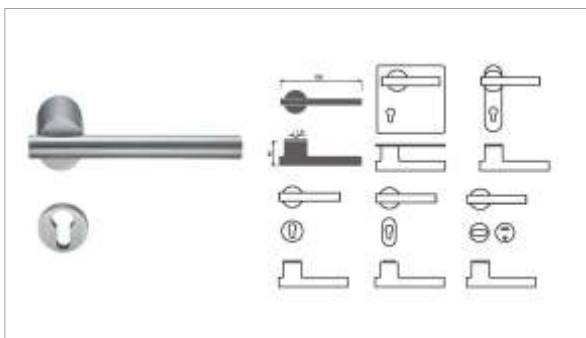

JLH174

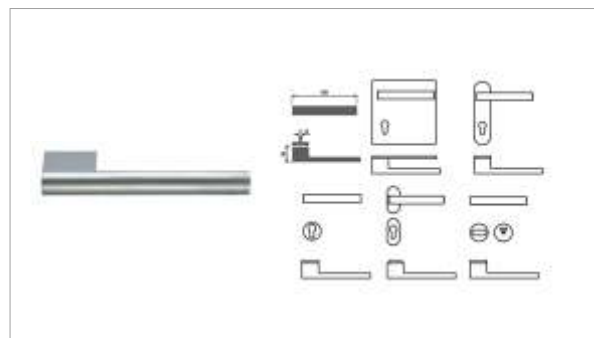

JLH176



JLH177

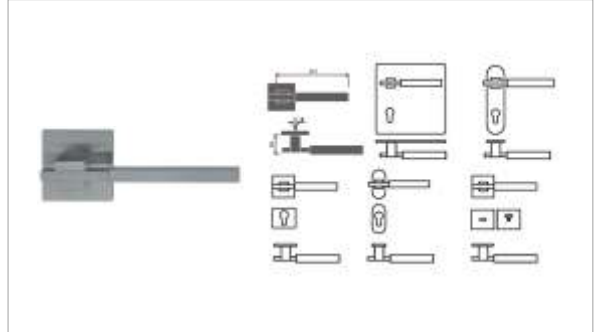

JLH178

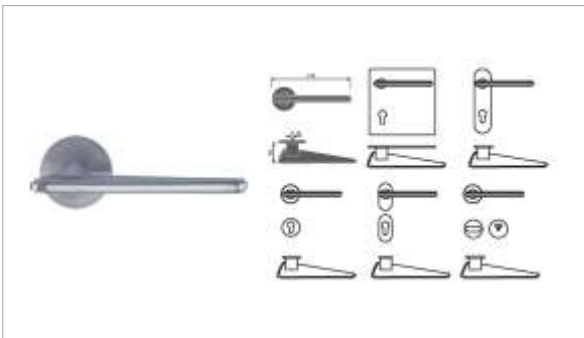

JLH179

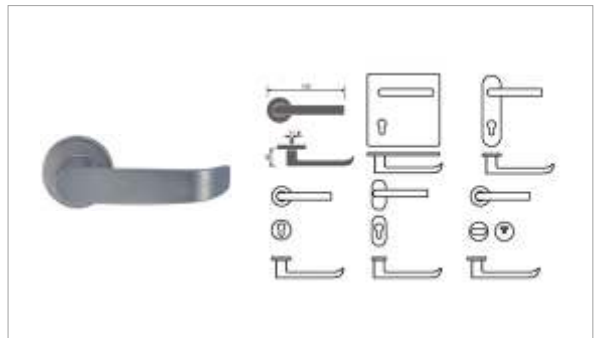

JLH180

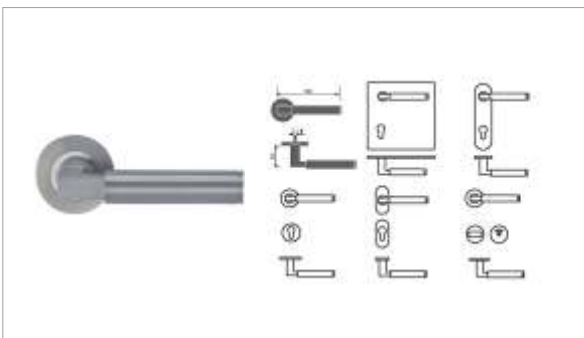

JLH181

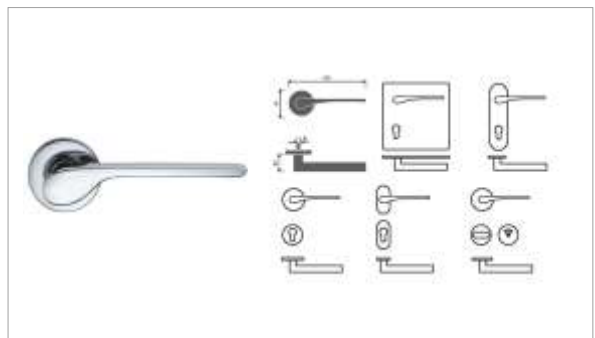

JLH182

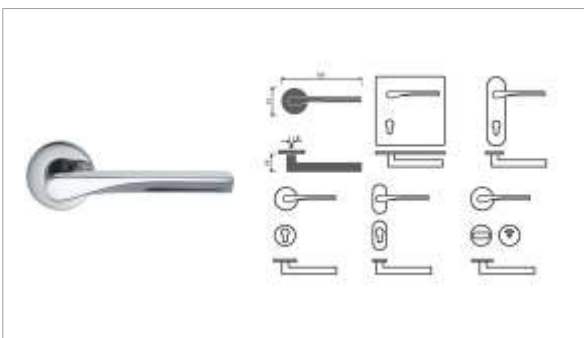

JLH183

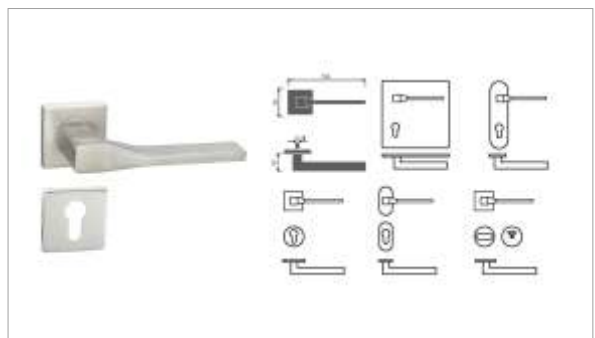

JLH184

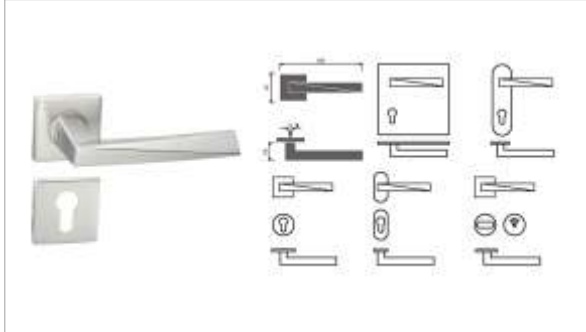

JLH185

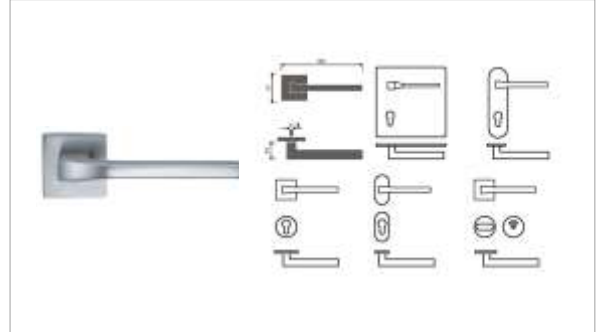

JLH186

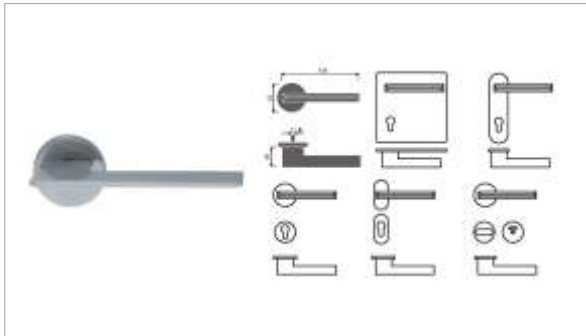

JLH187

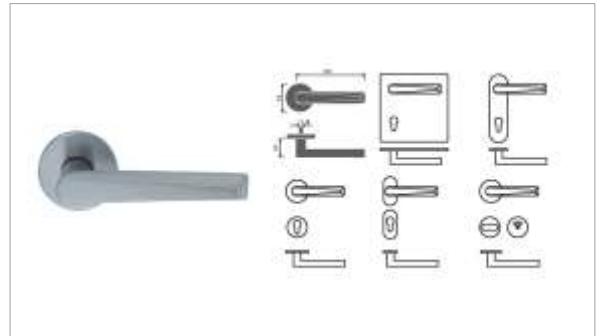

JLH188

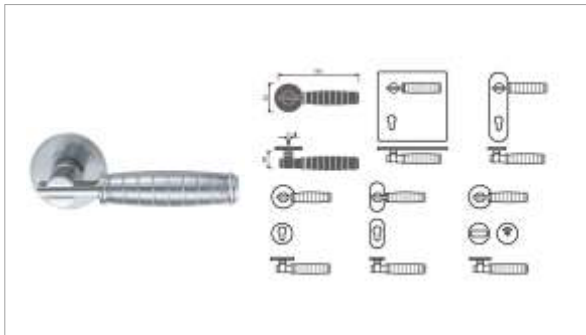

JLH189

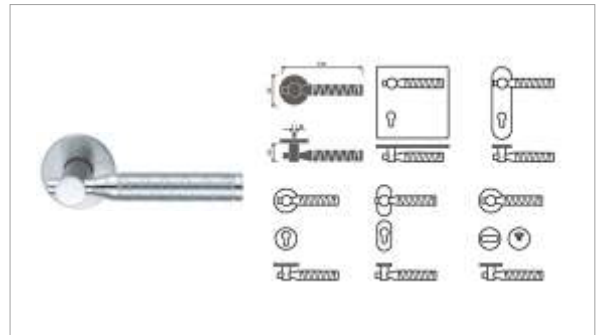

JLH190

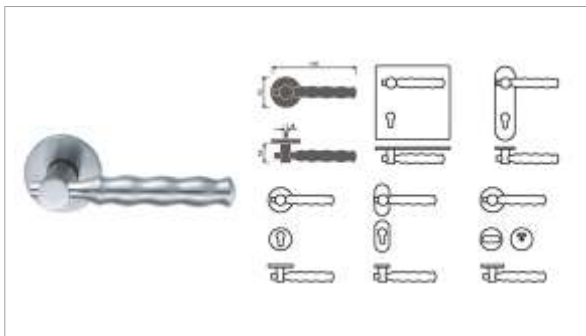

JLH191

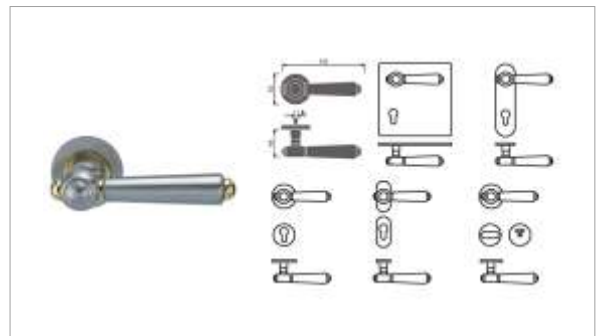

JLH192

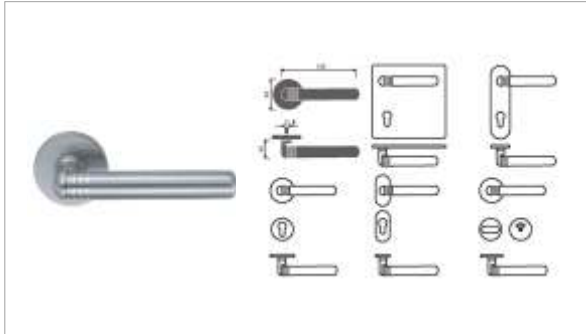

JLH193

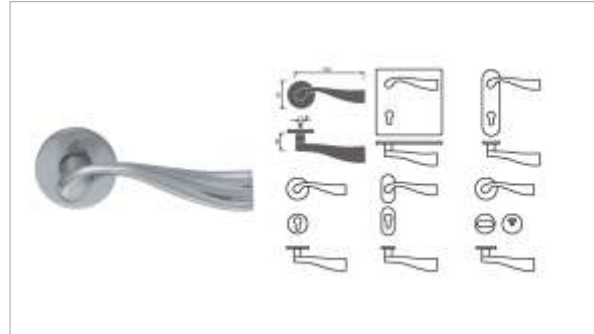

JLH194

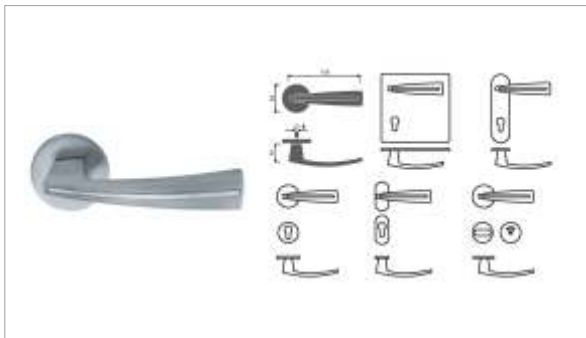

JLH195

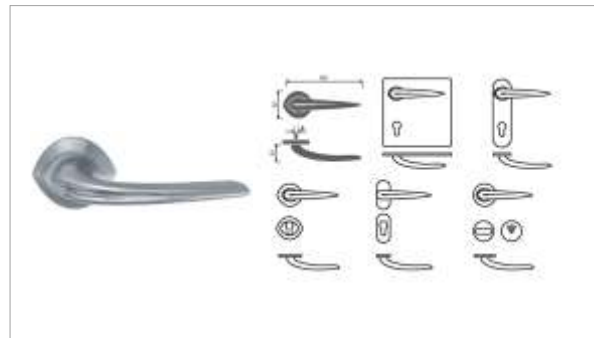

JLH196

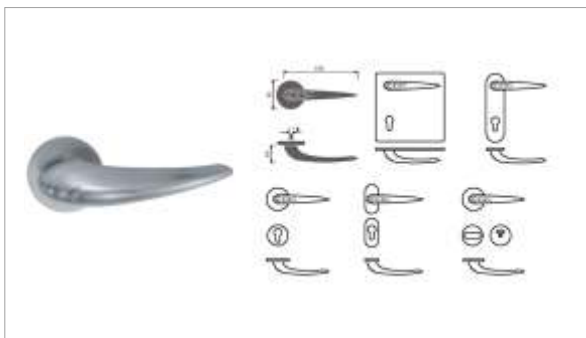

JLH197

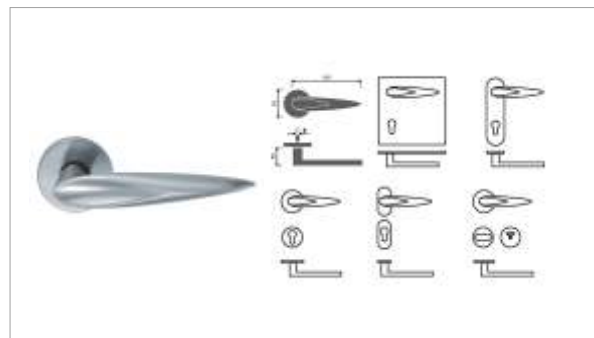

JLH198

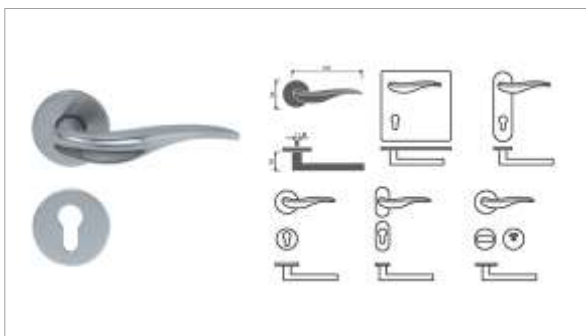

JLH199

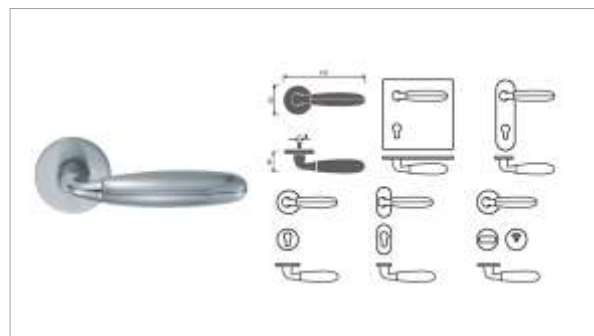

JLH201



JLH202



JLH203



JLH204



JLH205



JLP-01



JLP-01S-WC

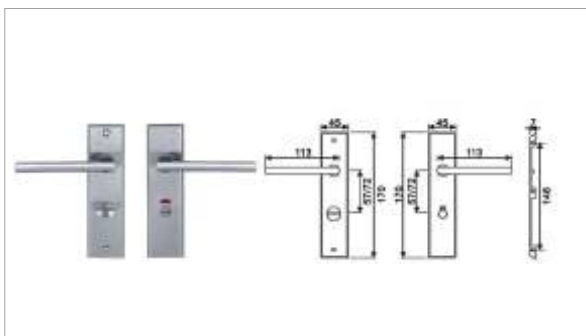

JLP-02

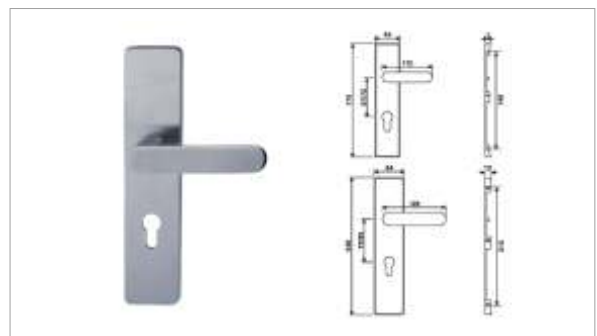

JLP-02S-WC

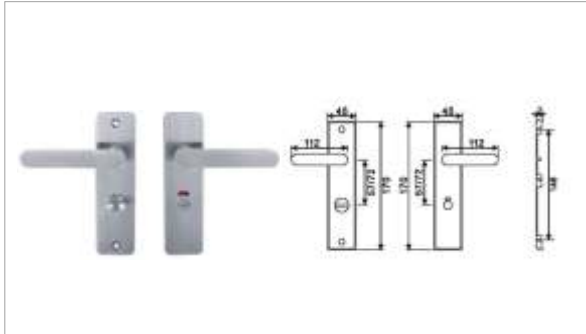

JLP-03

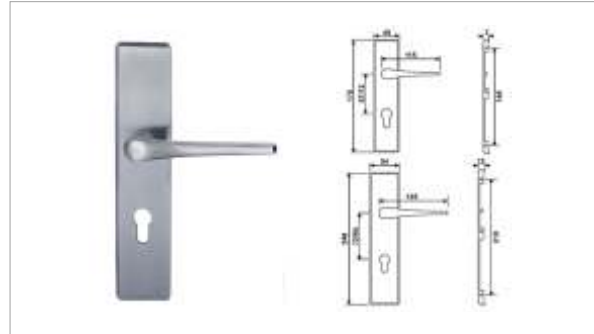

JLP-03S-WC

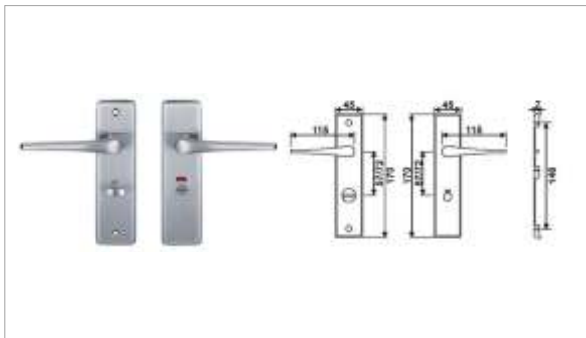

JLP-04

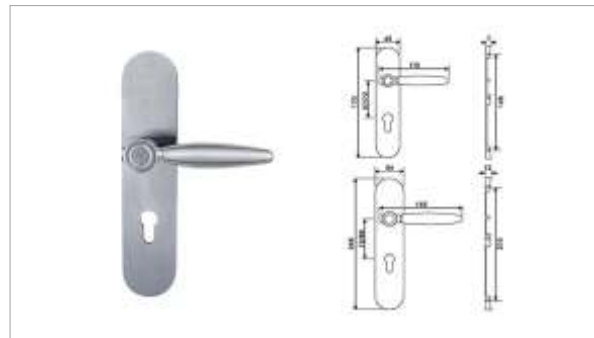

JLP-04S-WC

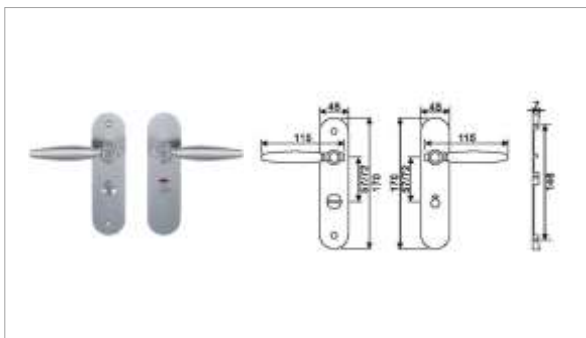

JLP-05

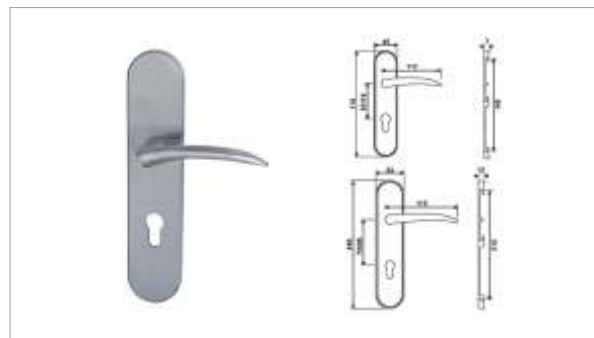

JLP-05S-WC

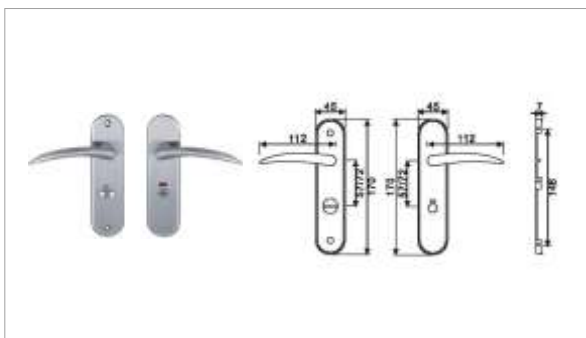

JLP-06



JLP-06S-WC

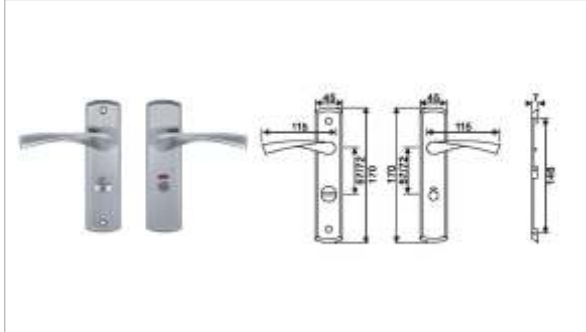

JLP-07

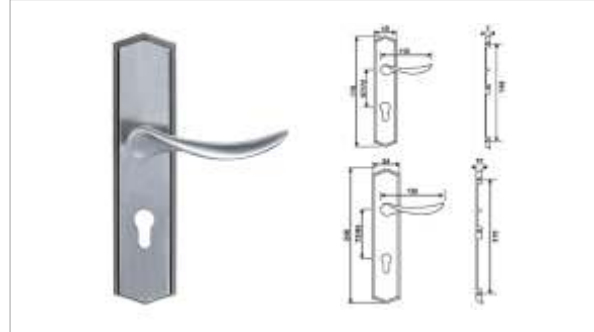

JLP-07S-WC

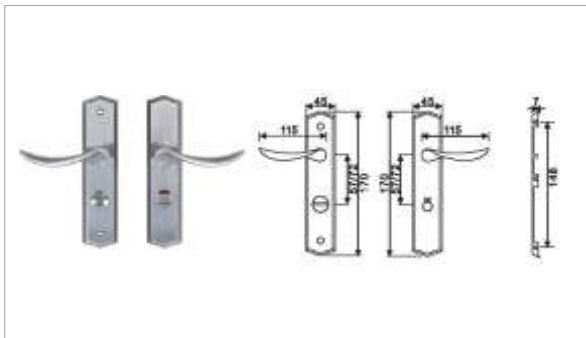

JLP-08



JLP-08S-WC

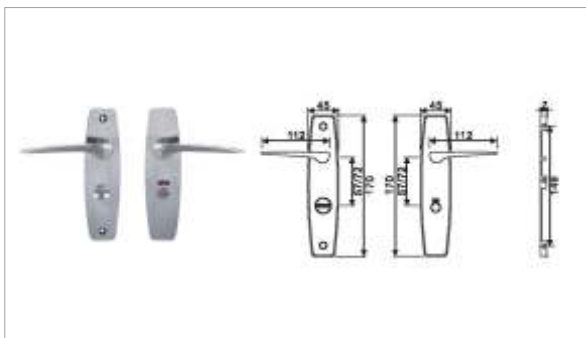

JLP-09

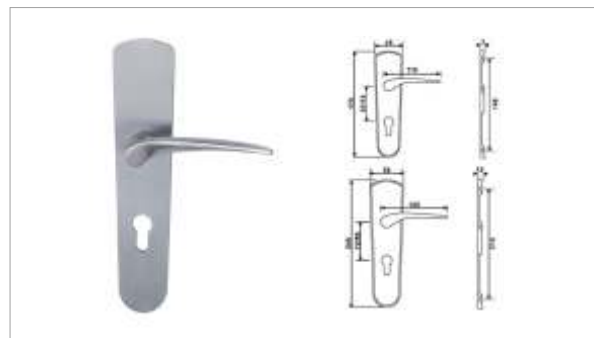

JLP-09S-WC

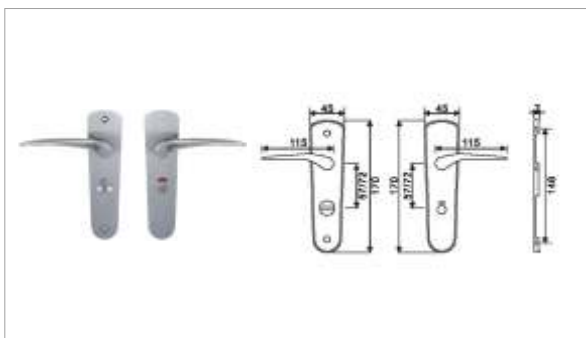

JLP-10



JLP-10S-WC

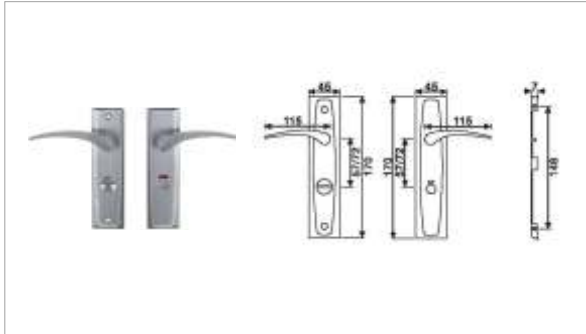

JLP-11



JLP-11S-WC

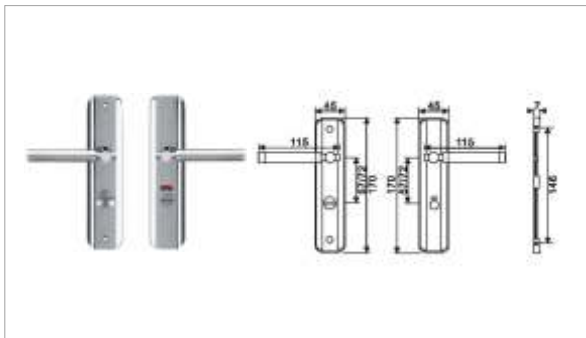

JLP-12

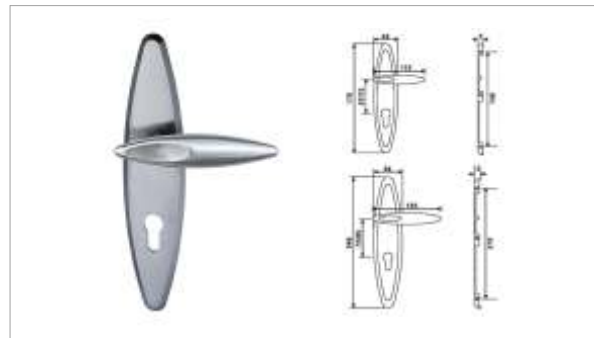

JLP-12S-WC

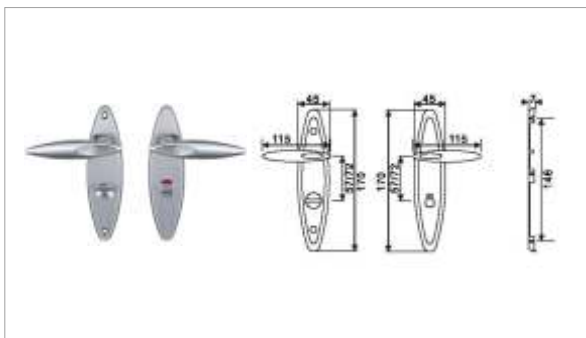

JLP-13

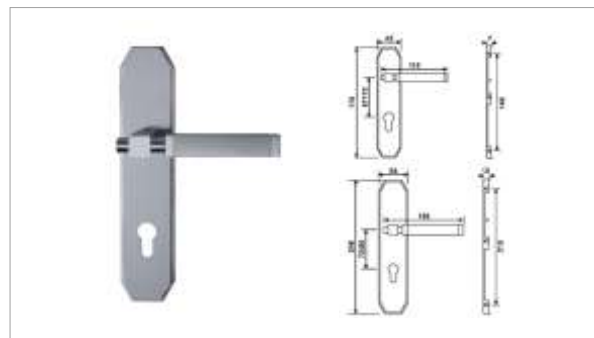

JLP-13S-WC

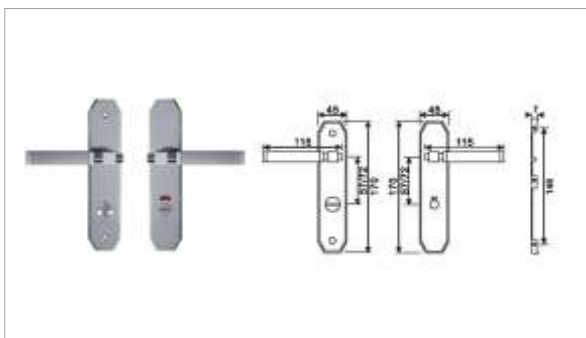

JFK002

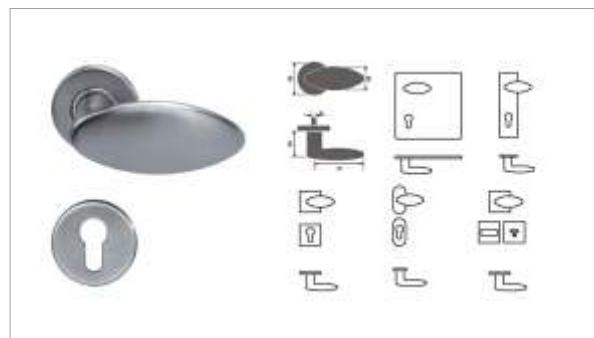

LB401

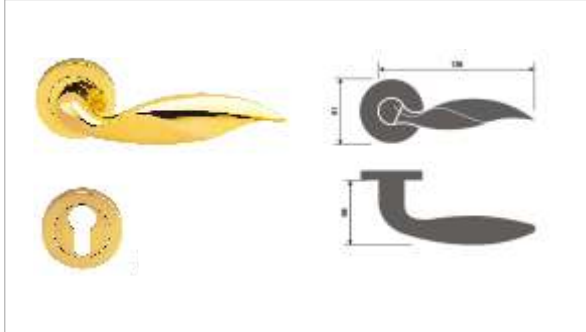

LB402

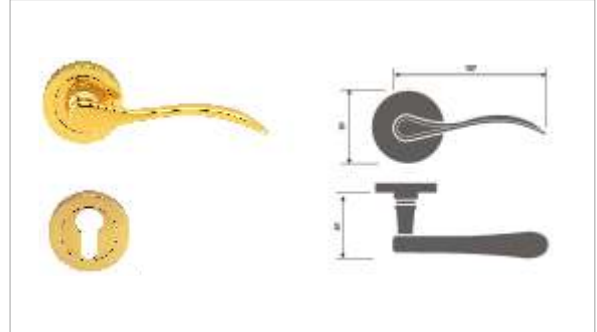

LB403



LB404



LB405

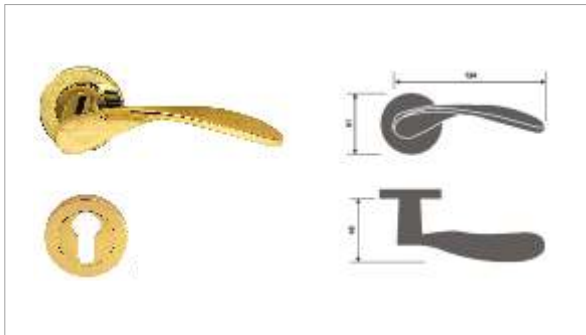

LB406

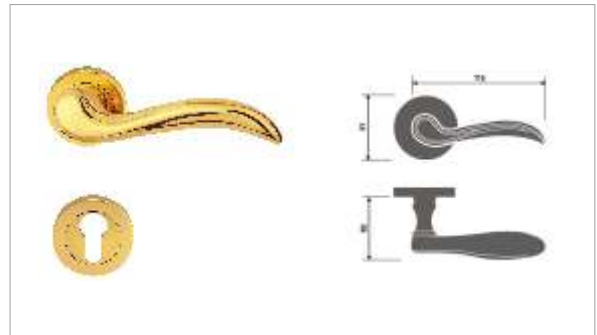

LB407

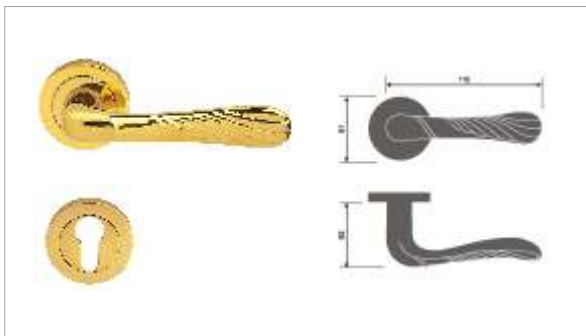

LB408

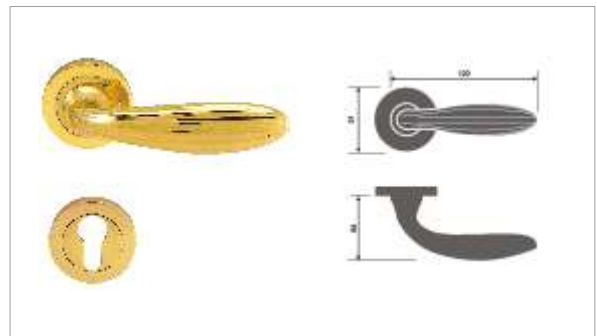

A5-704 BL



A5-592 SN



A5-559 BL



A5-801 SN



A25-811 BL/CP



A25-813 BL/CP

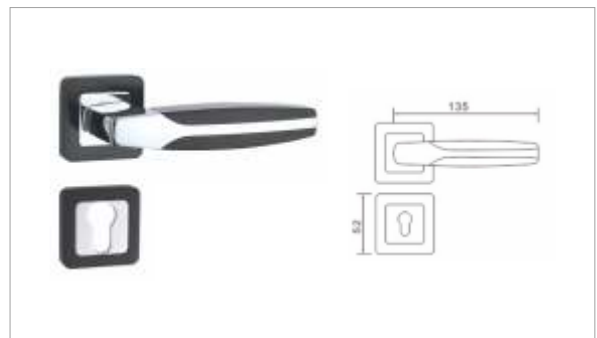

A9-653 SN

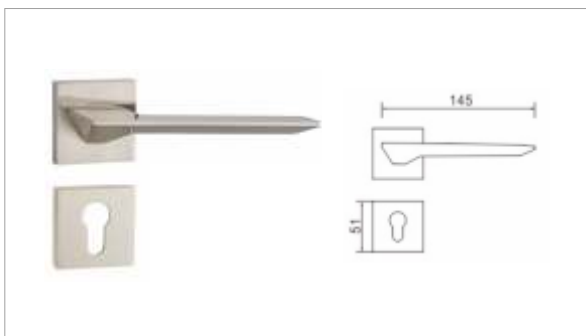

A7-685 SN

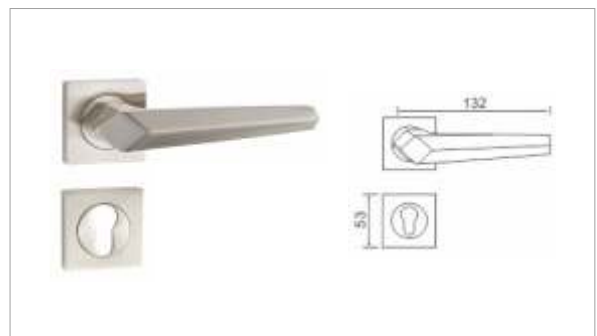

A9-690 ORC

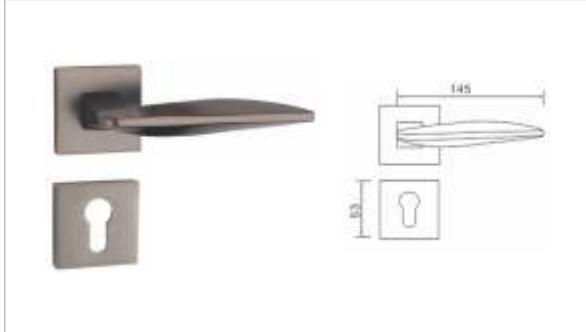

A9-691 ORC

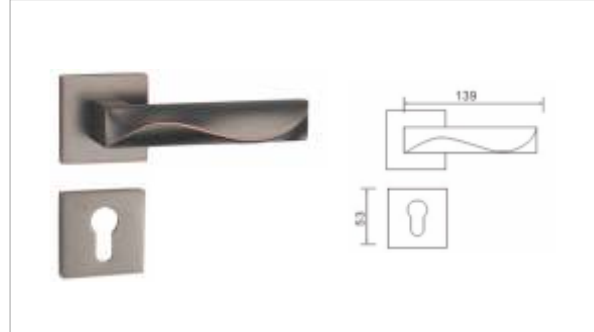

5881-592 PVD

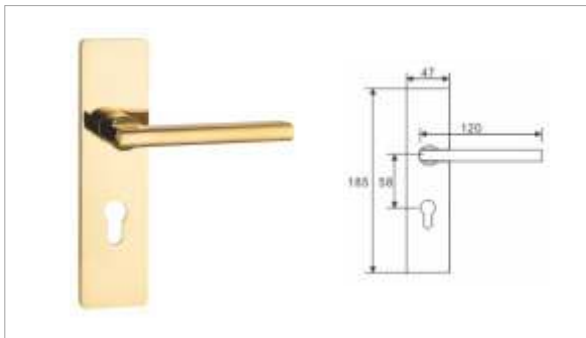

5881-704 BL

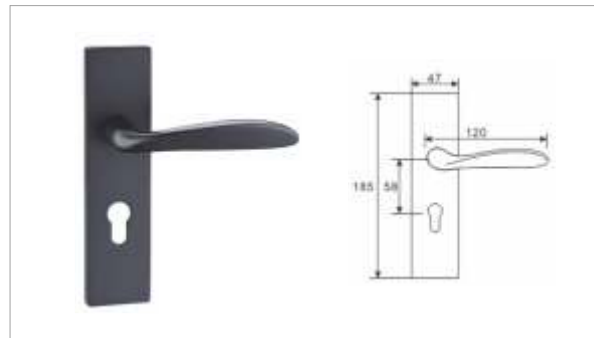

5025-326 ORB

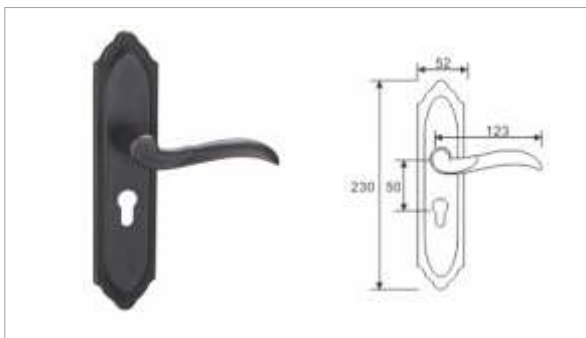

5027-328 COF

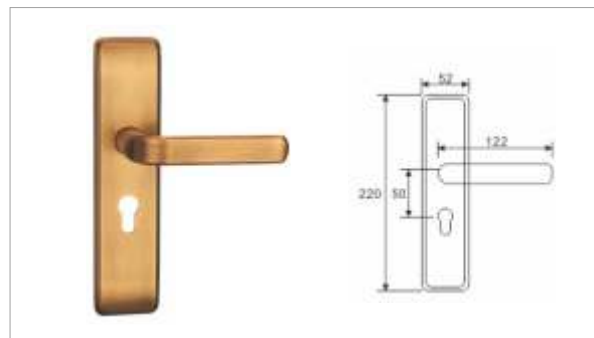

58150-704 DAB

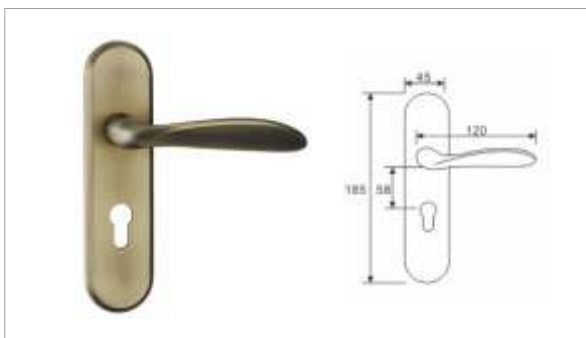

58150-704 SN

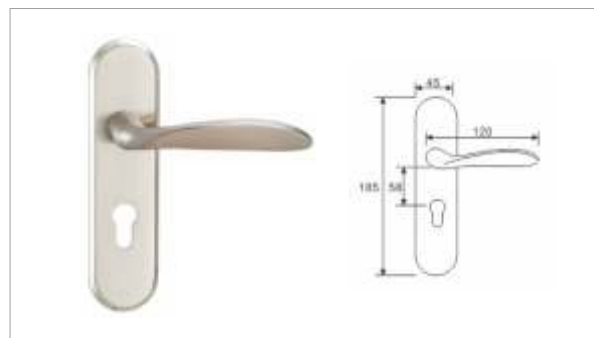

AL-112 OX

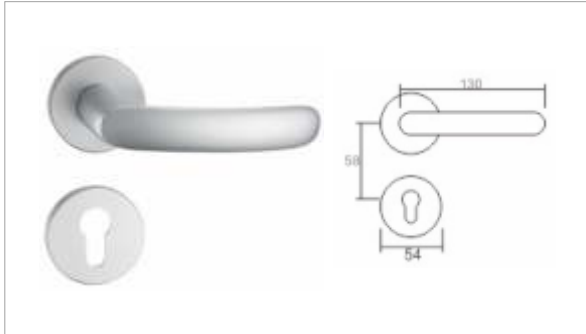

AL-113 OX

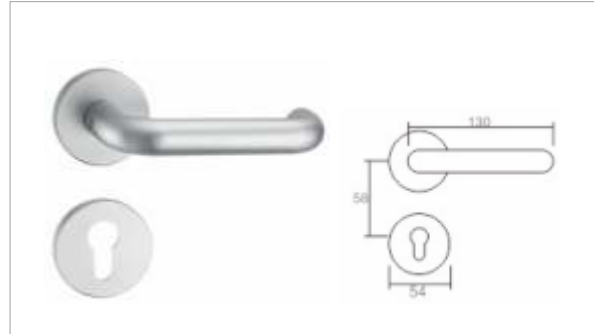

AL-114 OX

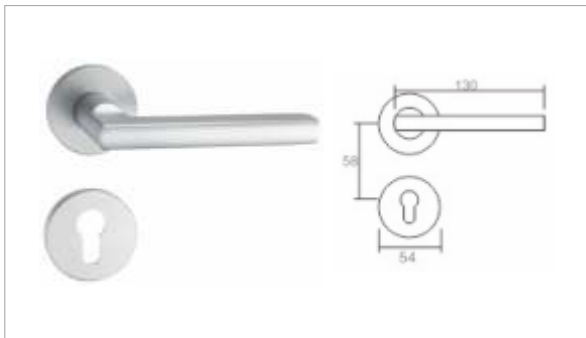

AL-115 OX

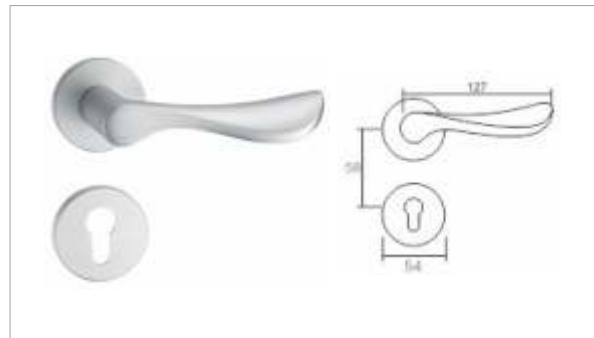

AL5802-111 BL

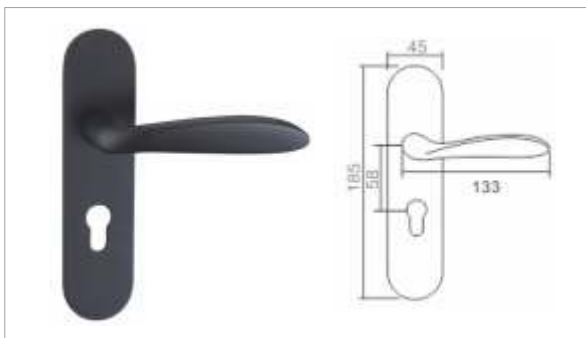

AL5802-115 BL

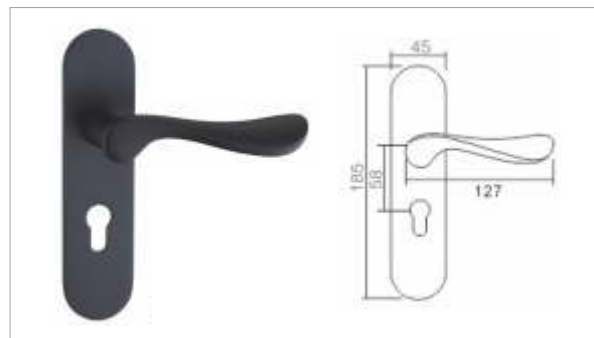

AL5803-114 SG

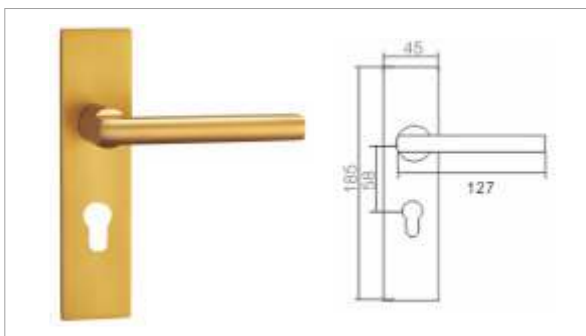

AL5804-133 SG

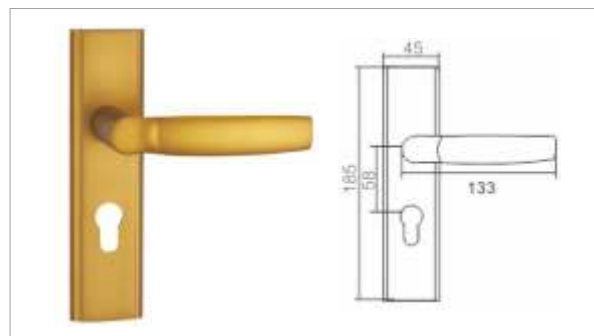

Rose-A

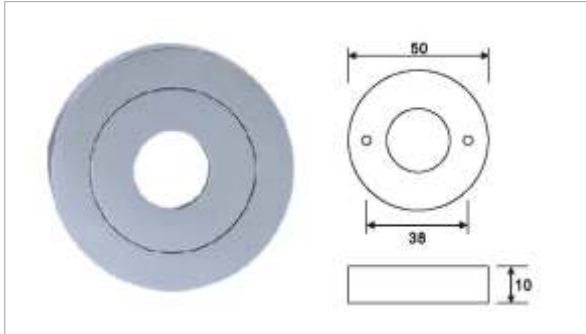

Rose-B

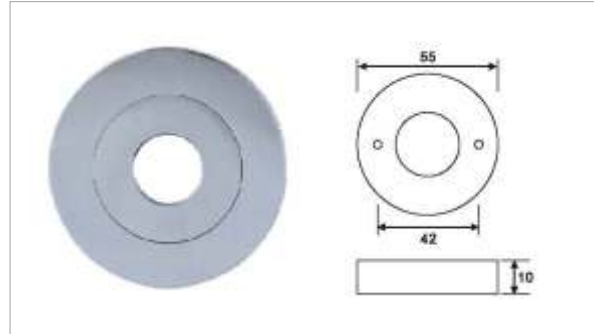

Rose-C

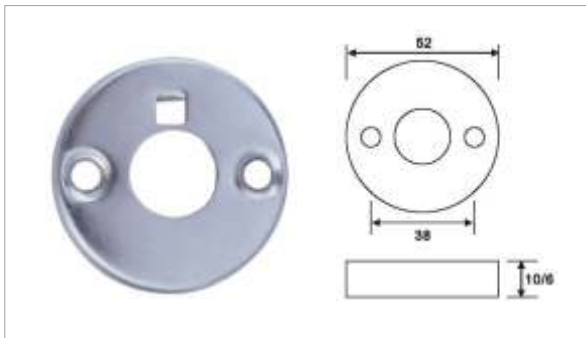

Rose-D



Rose-E

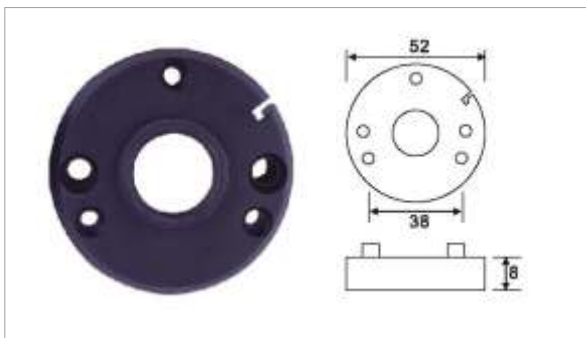

Rose-F

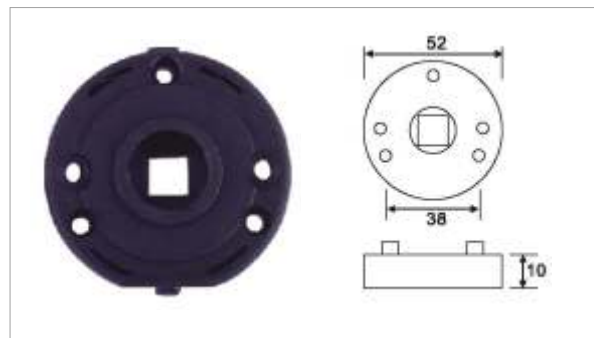

Rose-G

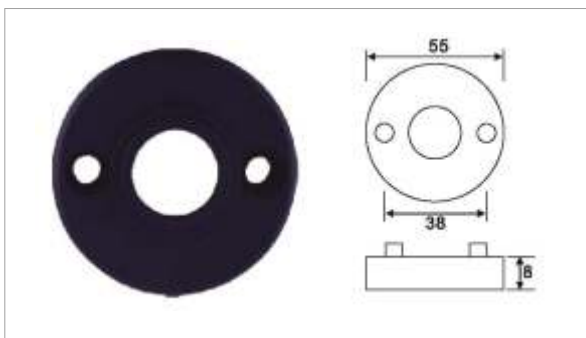

Rose-H

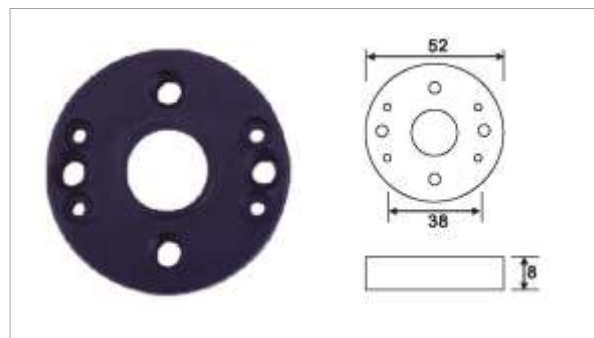

Rose-I

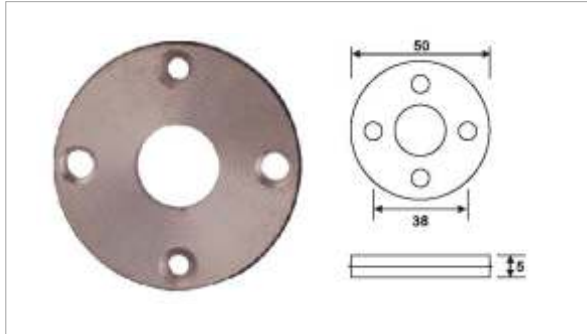

Rose-J

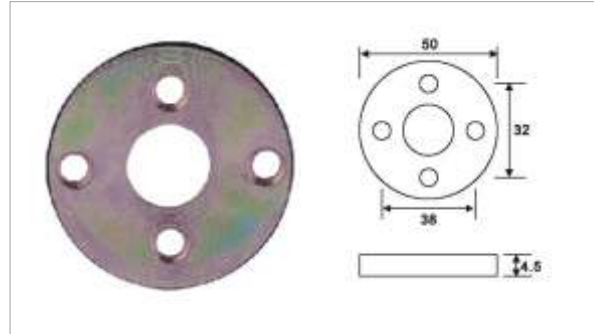

Rose-K

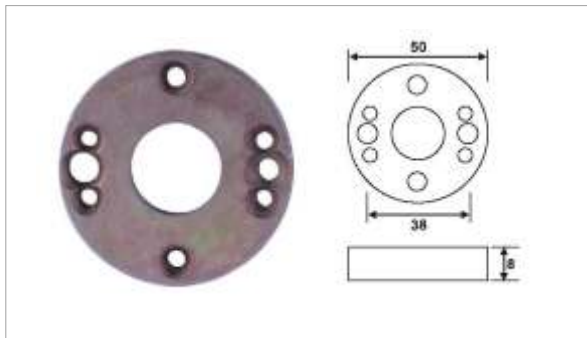

Rose-L

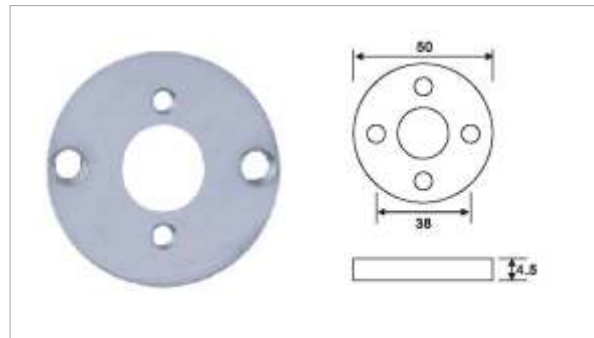

E-1

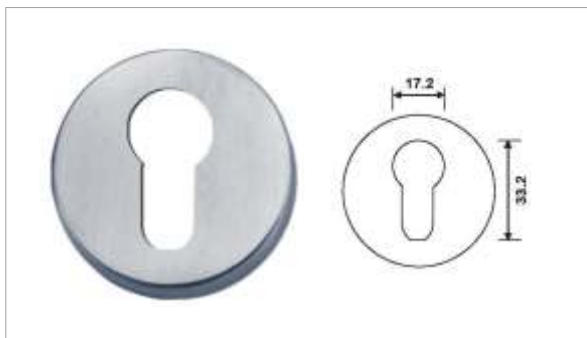

E-2

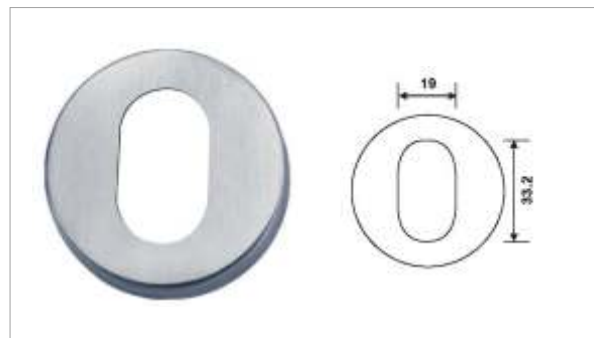

E-3

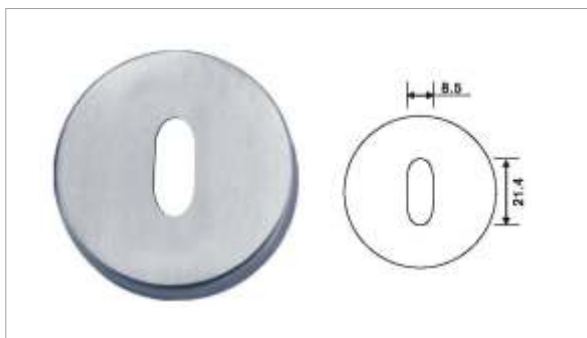

E-4

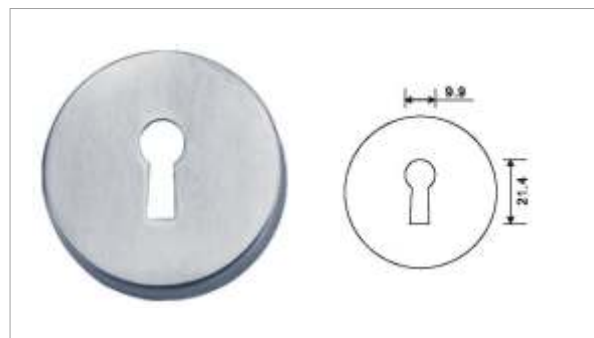

E-5

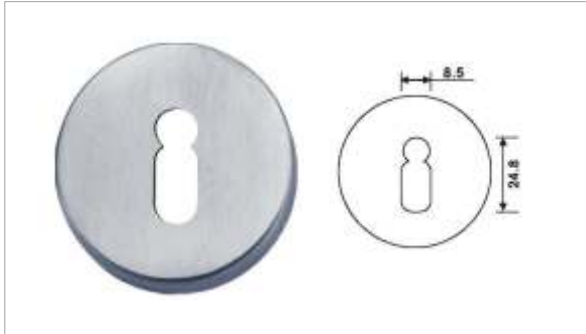

E-6

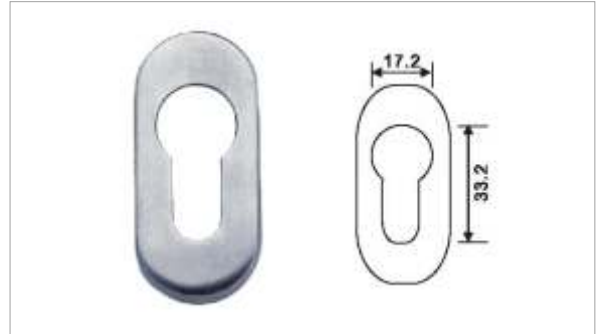

E-7

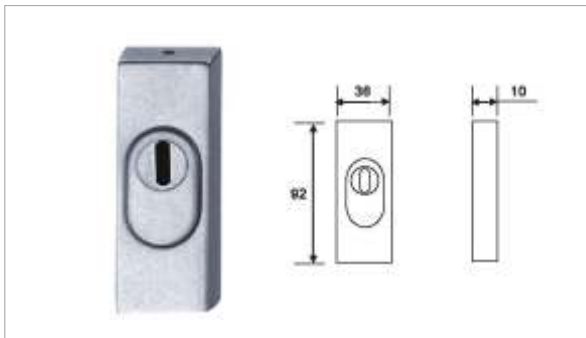

E-8

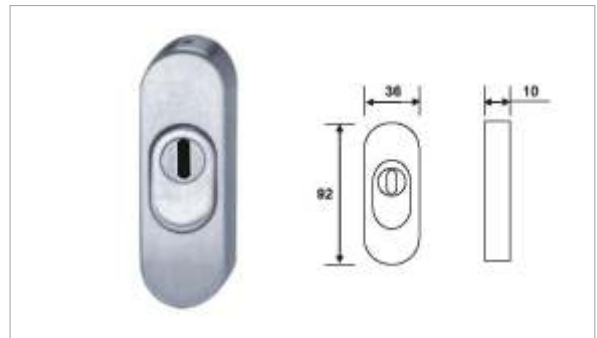

E-9

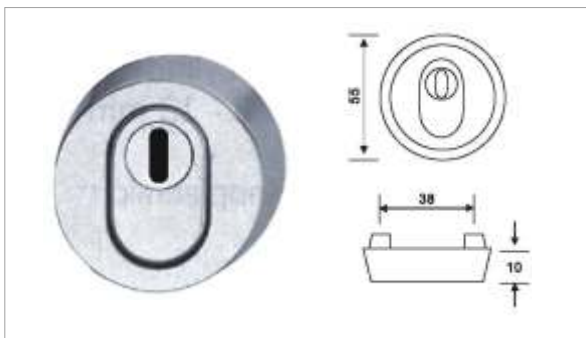

E-10



E-11



S-1

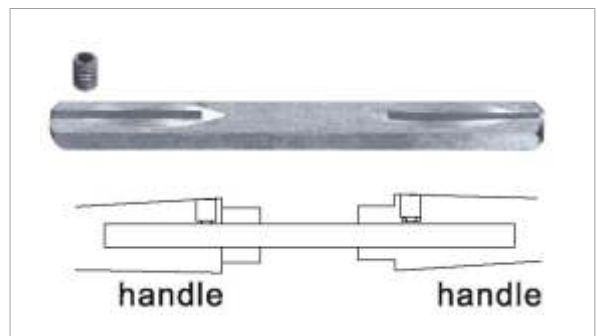

S-2

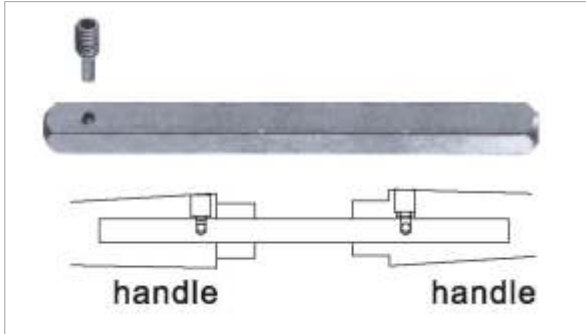

S-3

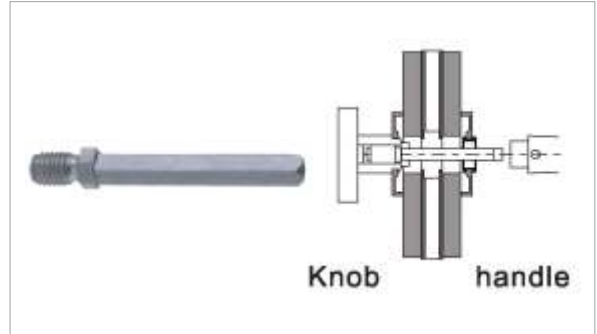

S-4

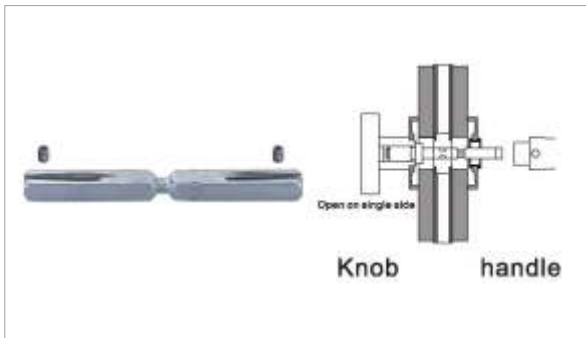

WH201



WH202

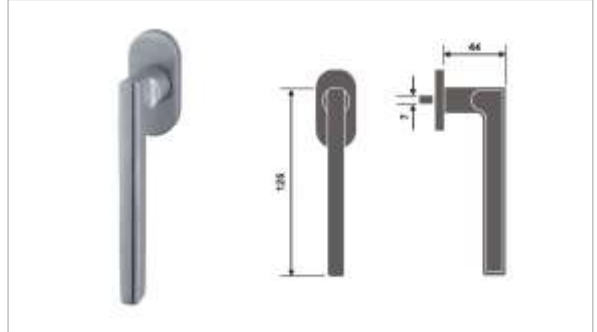

WH203

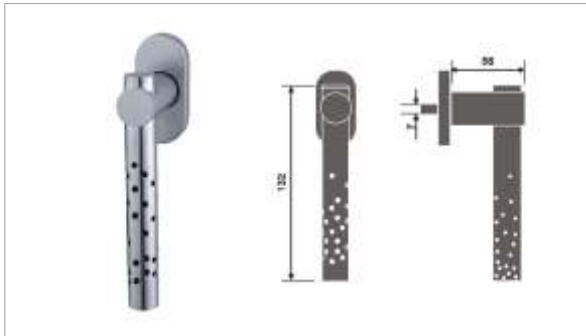

WH204



WH205



WH206

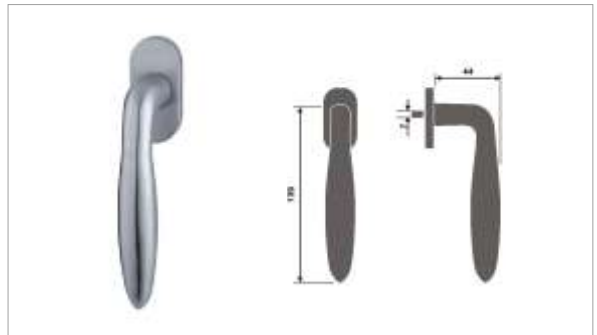

WH207

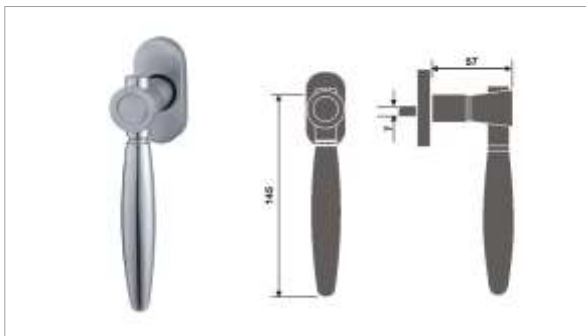

WH208

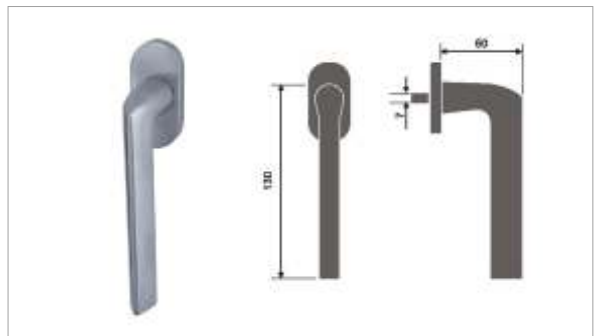

WH101



WH102



WH103



WH104



WH109



WH110



WH111



44





Hinge

- EN1935 Certification S/S Hinge
- **2-1:** Stainless Steel
- **2-2:** Brass
- **2-3:** Other

HINGES





STANDARDS

CLASSIFICATIONS

DIN EN 1935

As with any other building hardware hinges are also classified in an 8 digit code system. The classification standard divides the hinges in four use classes, and defines the maximal hinge moment that results from the generated frictional resistance in a hinge during its endurance test.

This standard is valid for door and window hinges for door leaves with a maximum weight of 160 Kg.

The standard specifies testing procedures and requirements with regard to:

- Uniaxial screw-on hinges
- Hinges with consolidated bolts
- For use on entrance doors and windows
- The currently valid DIN EN 1935 was published in April 2002 and has status of a national standard. It has been included in the German Building Standards Guide-lines B/Part 1 since 2005, meaning that it is anchored in the German Building Laws.

The 8 digit code is found according to these standards:

Digit 1 - Category of use - 4 grades are identified.

- Grade 1 Light duty
- Grade 2 Medium duty
- Grade 3 Heavy duty
- Grade 4 Severe duty

Digit 1 - Durability - 3 grades are identified.

for single-axis hinges MANUFACTURERd to this European standard:

Grade 3

10.000 test cycles, for light duty hinges on windows only

Grade 4

25 000 test cycles, for light duty hinges on windows and doors

Grade 7

200 000 test cycles, for medium, heavy and severe duty hinges on doors only

Digit 3 - Test door mass

Eight door mass grades related to single-axis hinges are identified in this European standard as shown below.

Test door mass grade	Door mass
0	10 kg
1	20 kg
2	40 kg
3	60 kg
4	80 kg
5	100 kg
6	120 kg
7	160 kg



Digit 4 - Suitability for fire/smoke door use

Two grades of suitability are identified for single-axis hinges:

Grade 0

Not suitable for fire/smoke resistant door assemblies

Grade 1

Suitable for fire/smoke resistant door assemblies subject to satisfactory assessment of the contribution of the single-axis hinge to the fire resistance of the specified fire/smoke door assemblies. Such assessment is beyond the scope of this European standard (see EN 1634-1)

Digit 5 - Safety

Single-axis hinges are required are identified in accordance with EN 1670:

Grade 0 No defined corrosion resistance.

Grade 1 Mild resistance.

Grade 2 Moderate resistance.

Grade 3 High resistance.

Grade 4 Very high resistance.

Digit 7 - Safety

Two grades of security are identified for single-axis hinges:

Grade 0

Not suitable for use on burglar-resistant door assemblies.

Grade 1

Suitable for applications requiring a degree of security. Annex C of this European standard details the hinge grade to use for the level of security required.

Digit 8 - Hinge grade

Fourteen grades are identified in this European standard and are detailed below.

GRADE	USAGE	DOOR MASS	DOOR MASS
1	WINDOW	10 000	10 KG
2	WINDOW	10 000	20 KG
3	WINDOW/DOOR	25 000	20 KG
4	DOOR	200 000	20 KG
5	WINDOW	10 000	40 KG
6	WINDOW/DOOR	25 000	40 KG
7	DOOR	200 000	40 KG
8	WINDOW	10 000	60 KG
9	WINDOW/DOOR	25 000	60 KG
10	DOOR	200 000	60 KG
11	DOOR	200 000	80 KG
12	DOOR	200 000	100 KG
13	DOOR	200 000	120 KG
14	DOOR	200 000	160 KG

INFORMATION

HINGES

GENERAL HINGE INFORMATION

There are a few factors determining proper hinge selection.

THE APPLICATION

Primary consideration is given to the type of door and frame for selection of a proper hinge configuration.

THE HINGE SIZE

Determined by door size, thickness, weight, frequency of use, and clearance required.

THE HINGE TYPE

The weight of the door frequency of use determine whether a heavy weight, standard weight or a plain bearing hinge should be used. Heavy weight hinges should always be used on heavy doors and doors where high frequency is expected.

WHICH METAL AND FINISH

Determined by considerations such as atmospheric conditions, location of doors, or special conditions in chemical laboratories, sewage disposal plants, etc.

While ferrous metal can be given a good rust-resisting base, it cannot be given the same absolute guarantee against rust as nonferrous metals and should not be used for extreme exposure.

HANDING OF HINGES

Loose joint hinges, pivot reinforced, electric, etc. are handed and should be specified right or left hand.

The hand of a hinge is determined from the outside of the door to which it is applied.

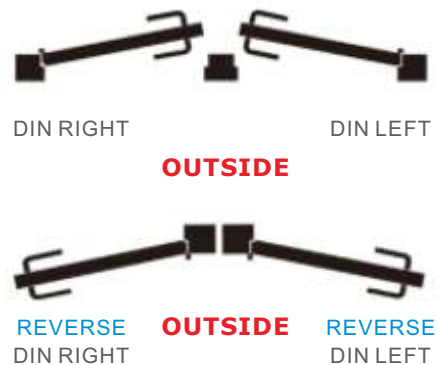

TIP OPTIONS

Institutions often require hospital type tips (barrel ends sloped) making it difficult to attach rope, wearing apparel, etc. Flat button tip is universally used as standard.

SPECIAL HINGE TYPES

Raised barrel, electric hinges, pivot reinforced hinges, hinges with non-removable pins, security studs, etc.



NUMBER OF HINGES REQUIRED

Use two hinges on doors 1000 x 2000 mm with app. 1435 mm between them.

Please note, that especially in public buildings where extra loads are incurred due to the high opening frequency and stress which is not always calculable (kindergarten, barracks etc.), sufficiently dimensioned hinges should be used, even if this would not have been necessary merely based on the door weight as such.

LOCATION OF HINGES ON DOOR

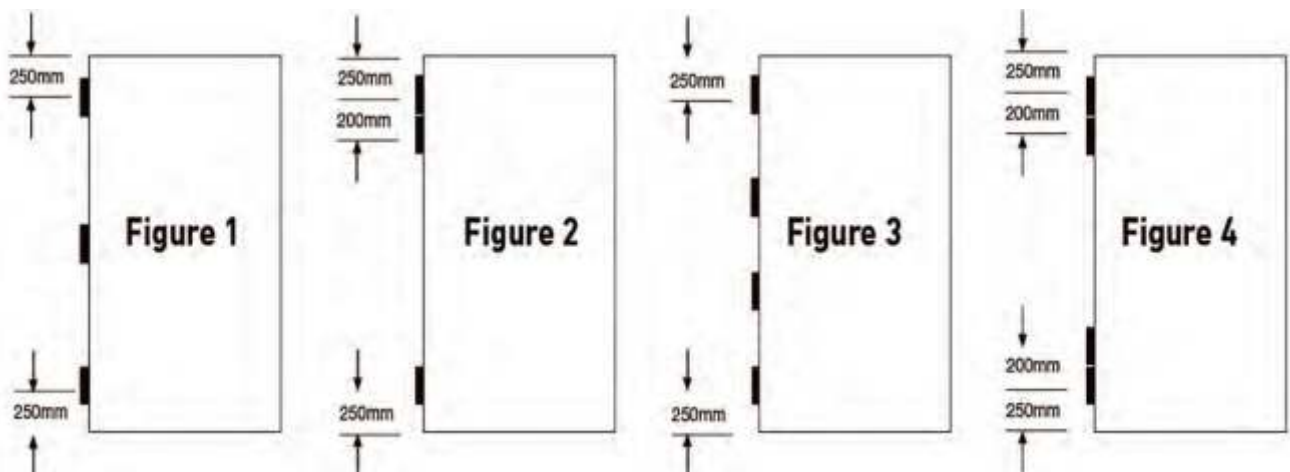

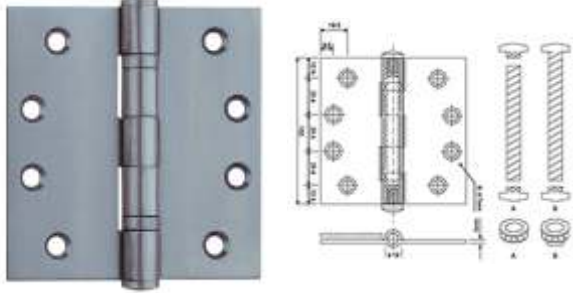

SS404030-2BB	Product	Model	CE Certification
	Hinge	4'x3'x3'mm 4'x4'x3'mm 4'x3.5'x3'mm 5'x3.5'x3'mm 5'x4'x3'mm	EN1935 : 2002 Grade : 476113013

3.3.864,-,25,34,,1/0,7G6dd:g76e:ba,9fcG6:a98

7TSTe,-,6DeGSbcg,bH,fdG

- Grade 1: light duty
- Grade 2: medium duty
- Grade 3: heavy duty
- **Grade 4: severe duty**

Digit 3 - Test door mass

- Grade 0: 10kg
- Grade 1: 20kg
- Grade 2: 40kg
- Grade 3: 60kg
- Grade 4: 80kg
- Grade 5: 100kg
- **Grade 6: 120kg**
- Grade 7: 160kg

7TSTe,0,-,DHGeg

- **Grade 1: Safe to use**

7TSTe,2,-,GFfcTeg

- **Grade 0: not suitable for use on, burglar-resistant doorassemblies.**
- Grade 1: suitable for applications requiring a degree of security.

4 7 6 1 1 3 0 13

Digit 2 - Durability

- Grade 3: 10,000 test cycles, for light duty hinges on windows only
- Grade 4: 25,000 test cycles, for light duty hinges on windows and doors
- **Grade 7: 200,000 test cycles, for medium, heavy and severe duty hinges on doors only.**

Digit 4 - Fire suitability

- Grade 0: not suitable for fire/smoke resistant door assemblies
- **Grade 1: suitable for fire/smoke , resistant door assemblies**

7TSTe,1,-,6bccbdTba,cGdTdeDaFG

- Grade 0: no resistance
- Grade 1: mild resistance
- Grade 2: moderate resistance
- **Grade 3: high resistance**
- Grade 4: very high resistance

Digit 8 - Hinge grade

- Grade 1: 10,000 test cycles / 10kg
- Grade 2: 10,000 test cycles / 20kg
- Grade 3: 25,000 test cycles / 20kg
- Grade 4: 200,000 test cycles / 20kg
- Grade 5: 10,000 test cycles / 40kg
- Grade 6: 25,000 test cycles / 40kg
- Grade 7: 200,000 test cycles / 40kg
- Grade 8: 10,000 test cycles / 60kg
- Grade 9: 25,000 test cycles / 60kg
- Grade 10: 200,000 test cycles / 60kg
- Grade 11: 200,000 test cycles / 80kg
- Grade 12: 200,000 test cycles / 100kg
- **Grade 13: 200,000 test cycles / 120kg**
- Grade 14: 200,000 test cycles / 160kg

SS-RT-05

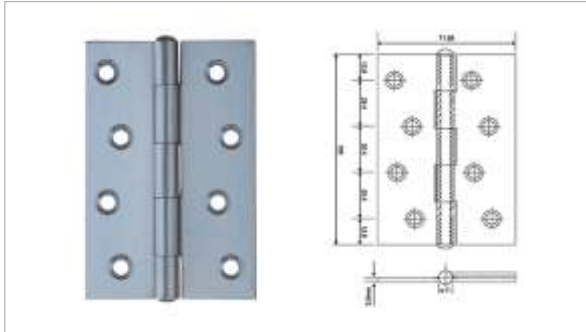

SS403030-PJ

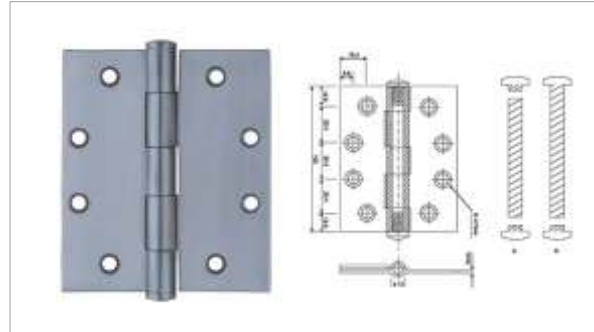

SS403020-NW

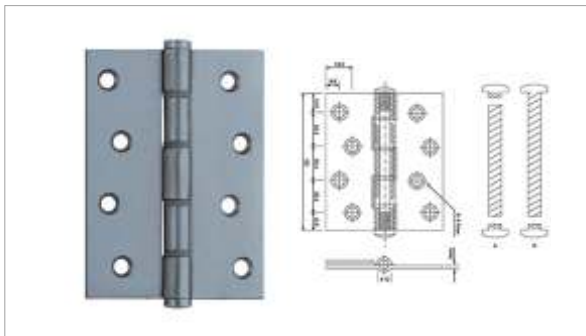

SS404030-SW

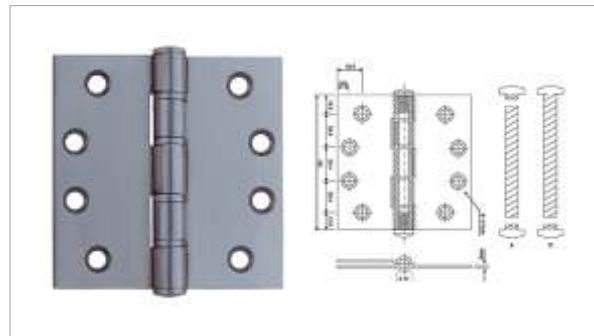

SS403020-DW

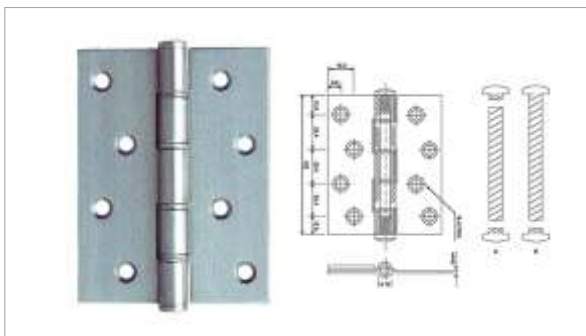

SS404030-2BB

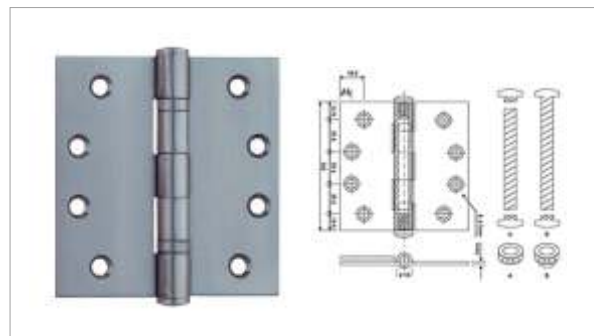

SS404030-4BB

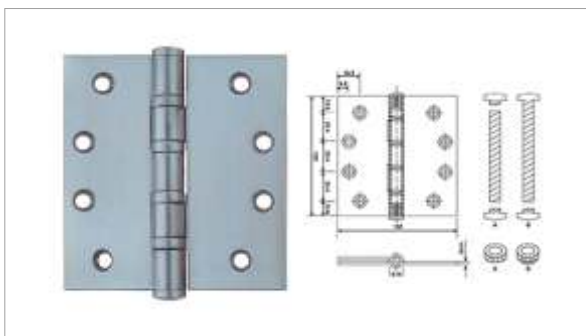

SS403520-3K-DW

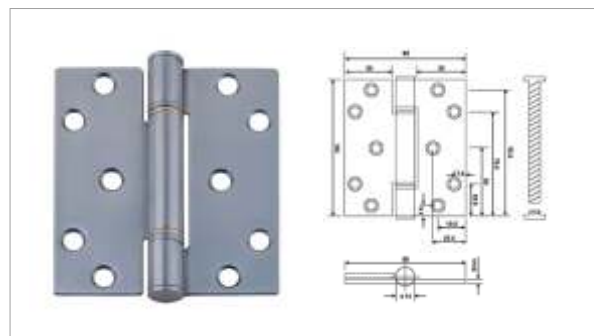

➤ This page product size can be customized.

SS404020-3K

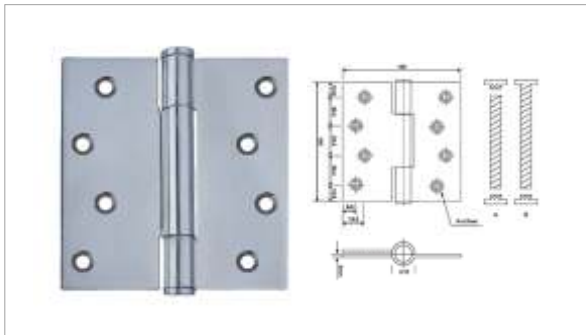

SS403030-RC

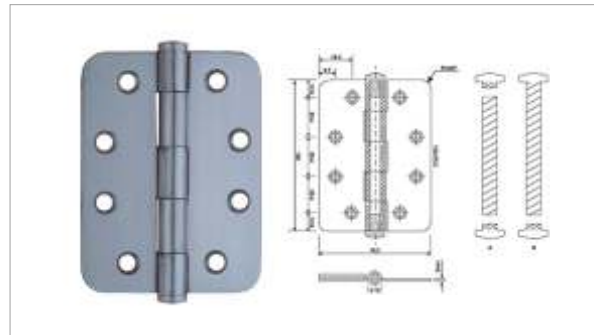

SS403020-OR

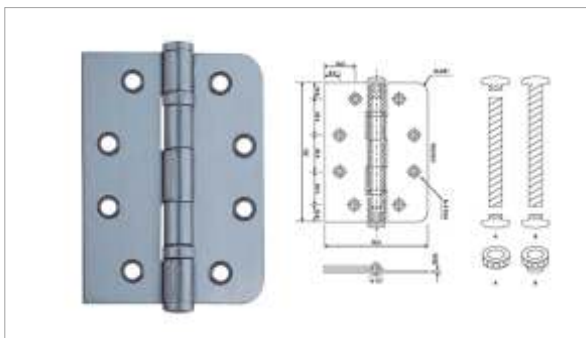

SS403020-L1

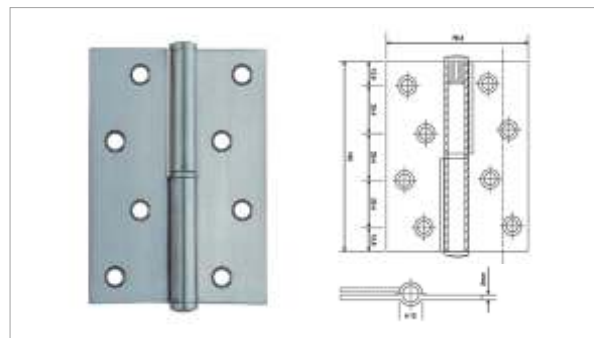

SS352525-L2

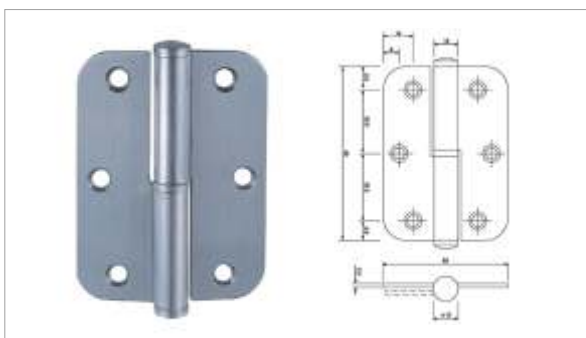

SS403530-L3

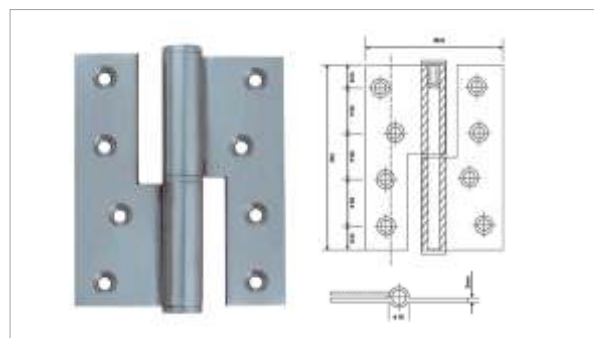

SS403530-L4

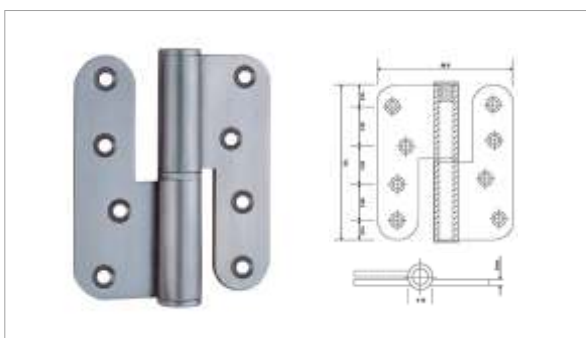

SS403030-RH

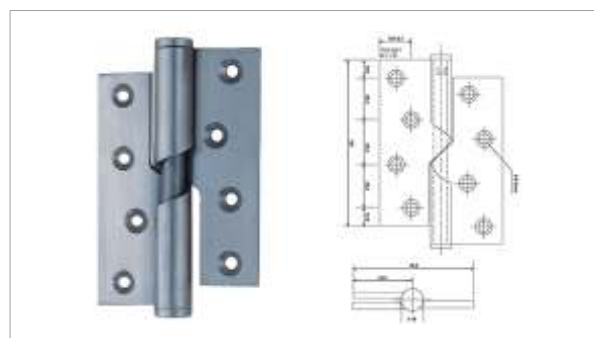

➤ This page product size can be customized.

SS403530-FH

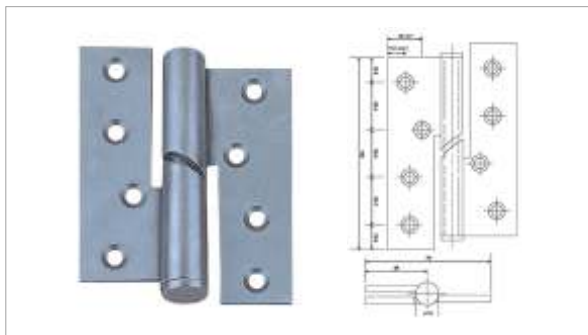

SS-FG-05

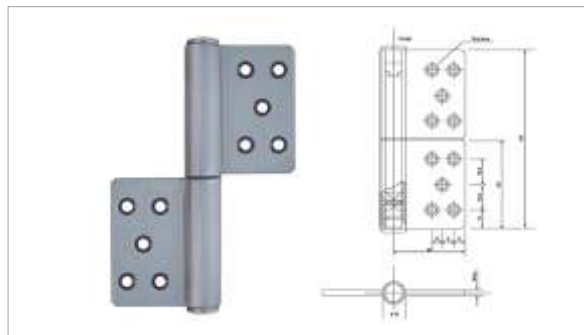

SS-FG-07

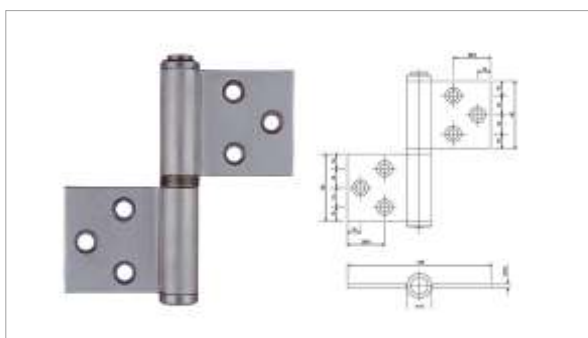

SS-FG-08

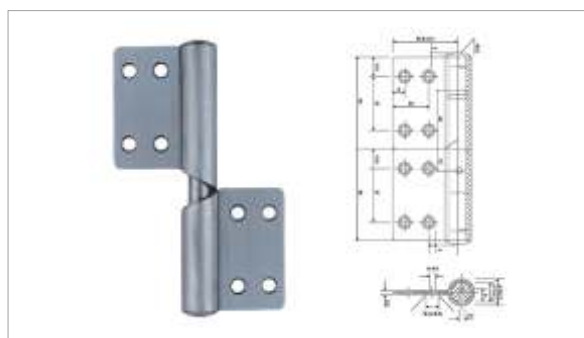

SS-FG-09

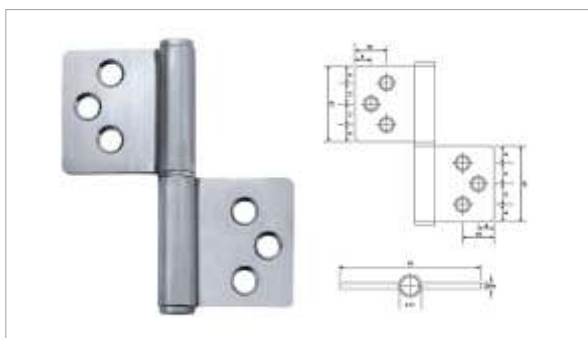

SS-FG-010

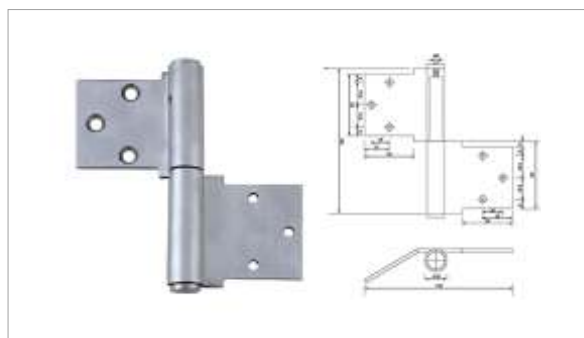

SS404030-S2

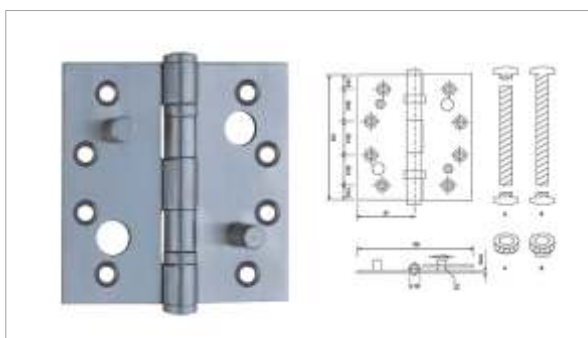

SS403025-S1

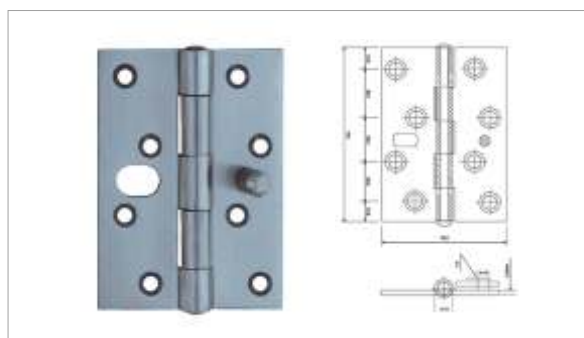

➤ This page product size can be customized.

SS403030-CK1

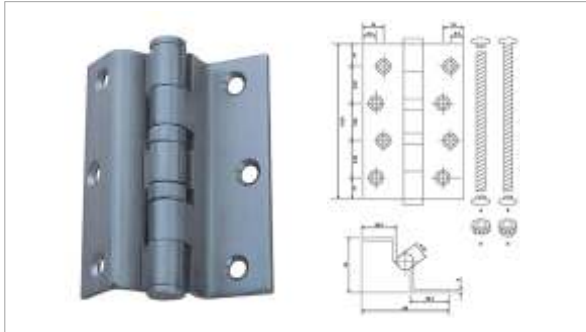

SS404030-CK2

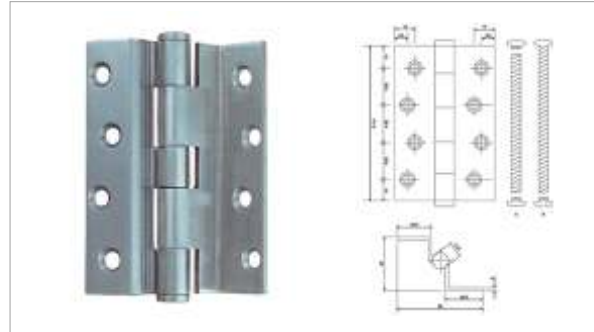

SS404020-CK3

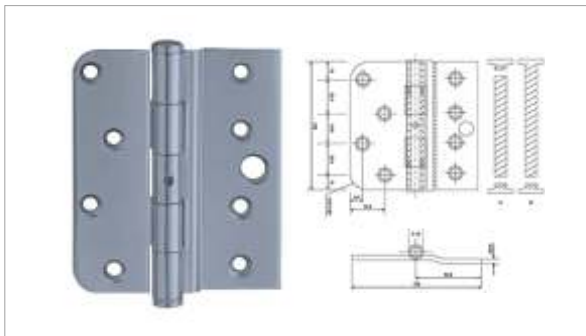

SS302415-CK4

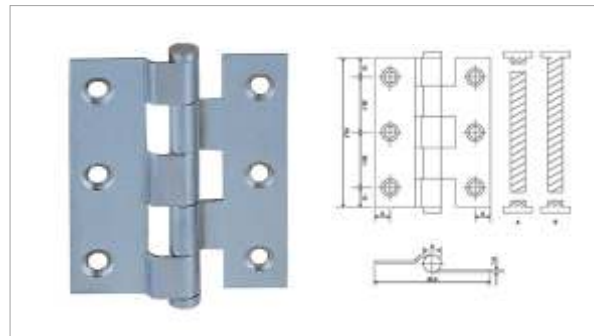

SS-DAS01-4"

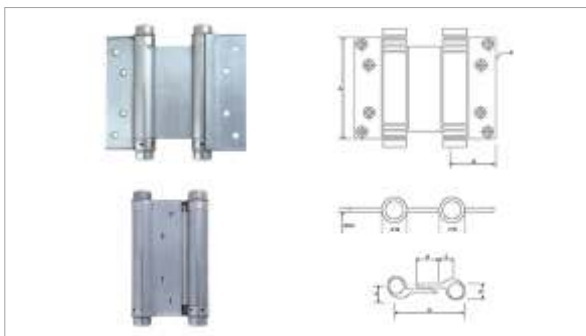

MS-DAS02-3"

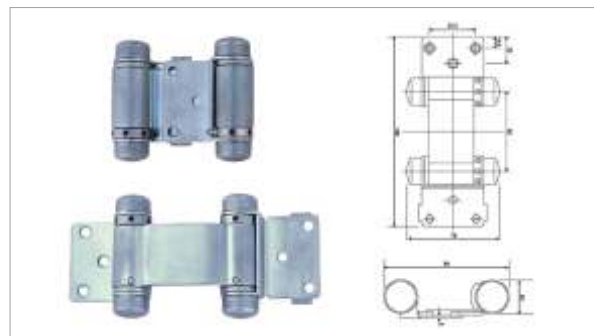

SS-SAS02-4"

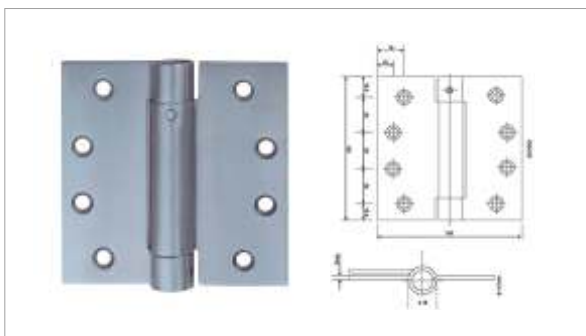

SS-SAS01-4"

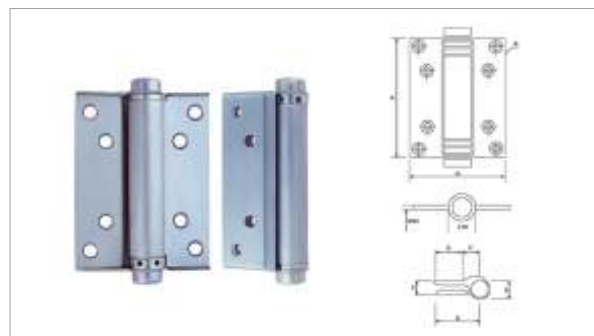

➤ This page product size can be customized.

SS-SAS03-4"

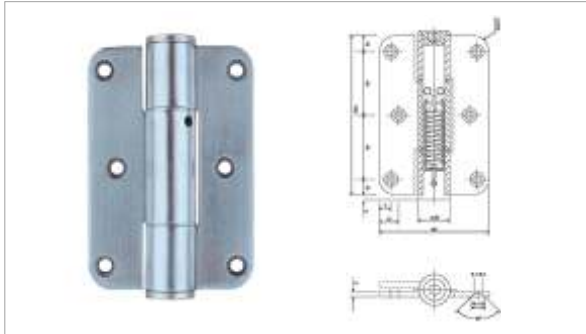

SS-SAS04-3.5"

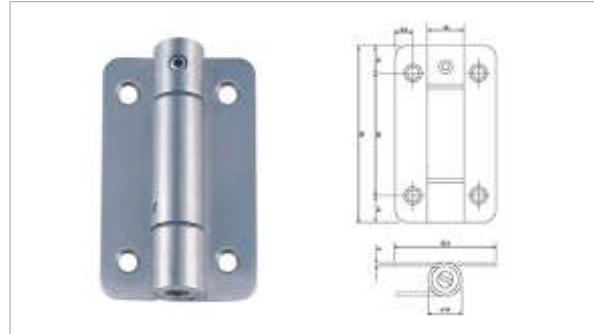

SS-HH-01

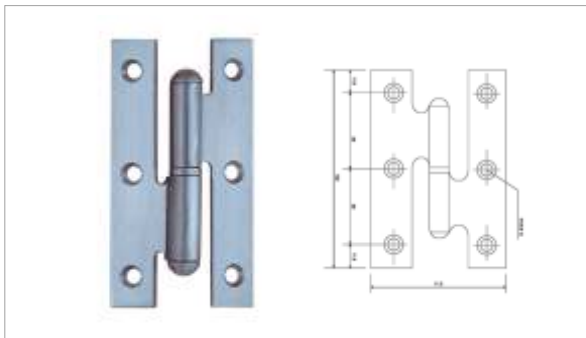

SS-HH-01-RC

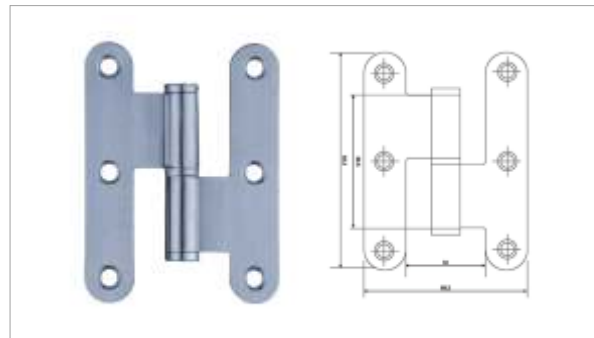

SS-FH-B02

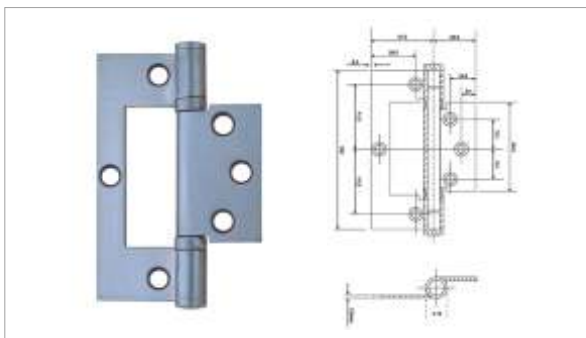

SS-FH-A01

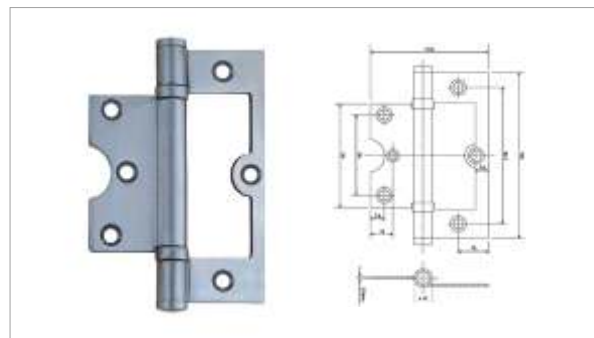

SS-PV-02

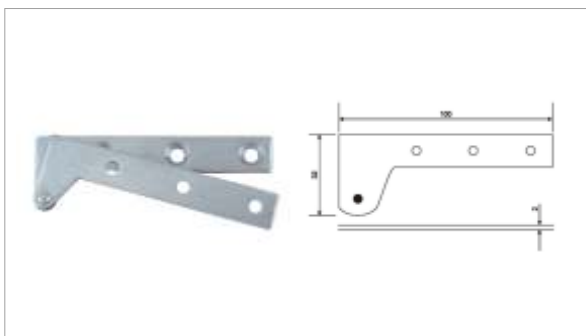

EMH158

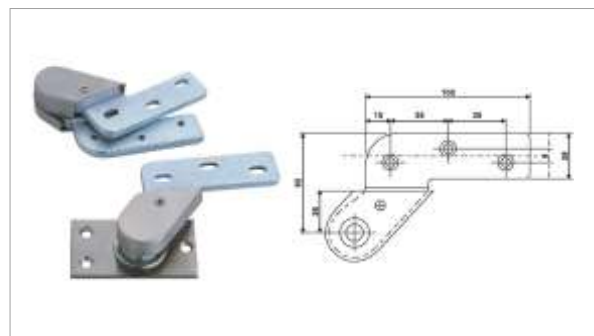

➤ This page product size can be customized.

SS-TL-01

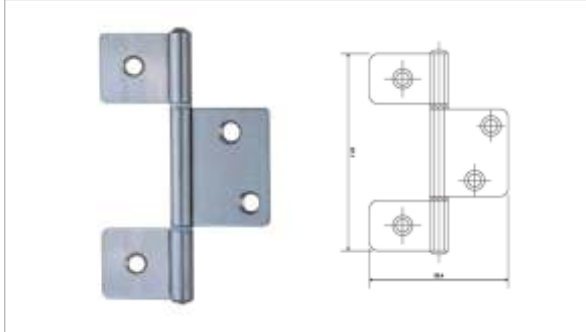

SS-TL-2BB-A01

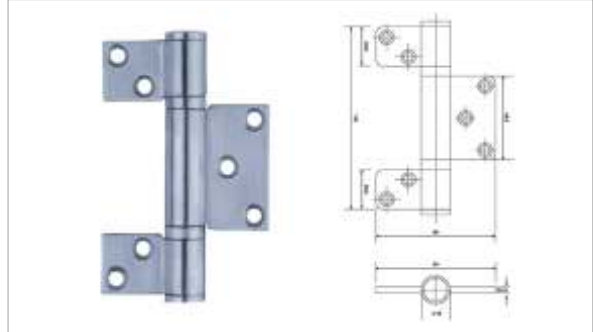

SS-TL-2BB-B01

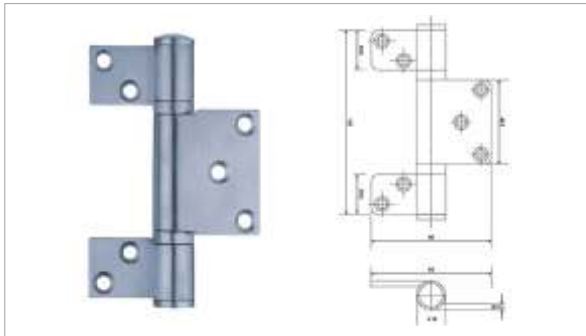

SS-TL-2BB-C01

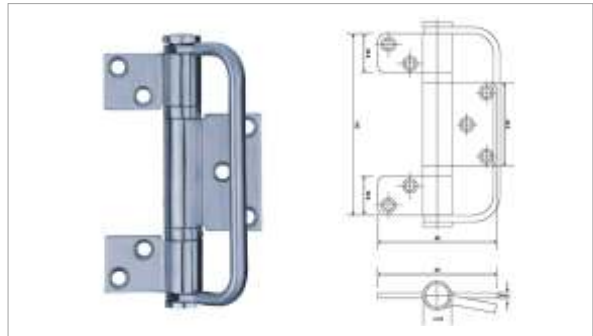

➤ This page product size can be customized.

SB-BB-016

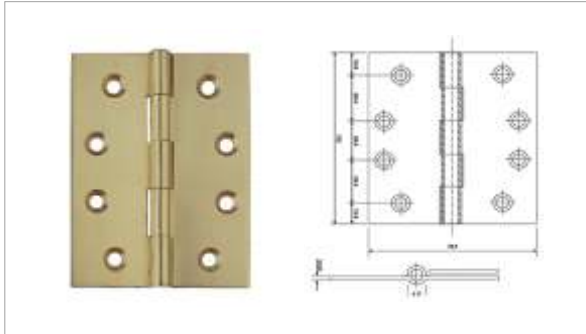

SB-DW-09

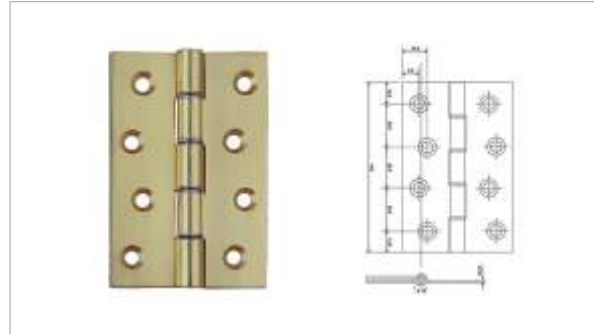

SB-DW-101

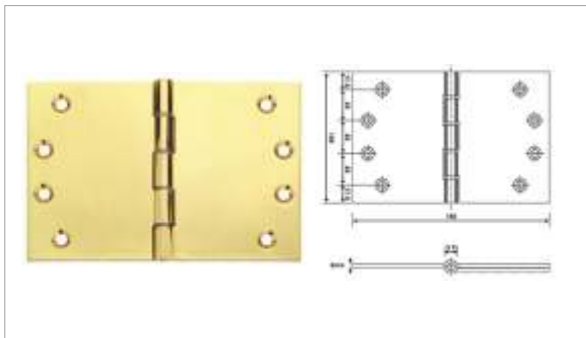

SB403030-PJ-T

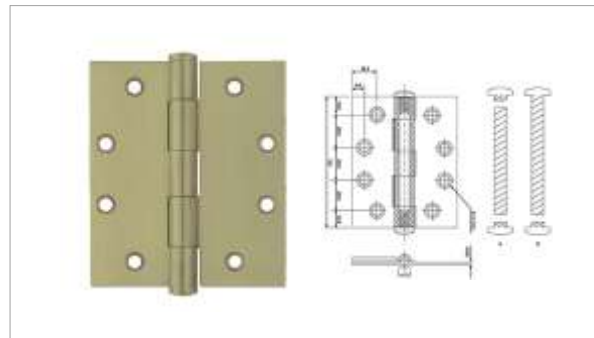

SB403030-2BB

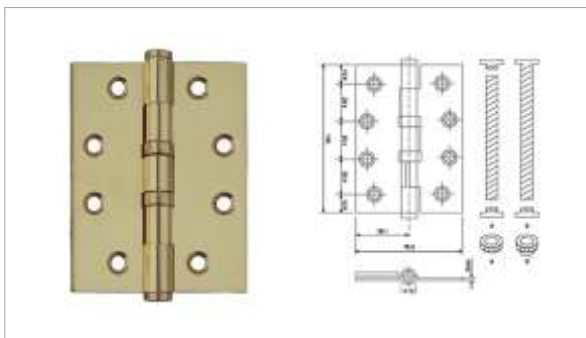

SB403030-4BB

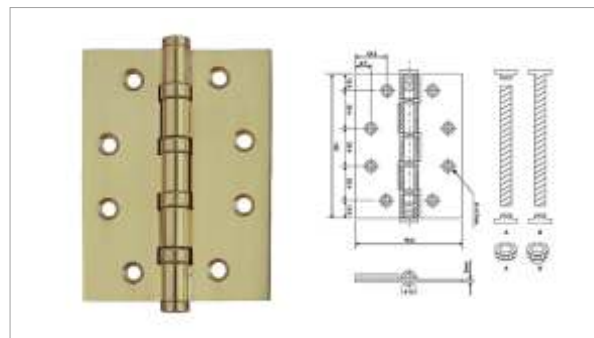

SB403530-2BB-BT

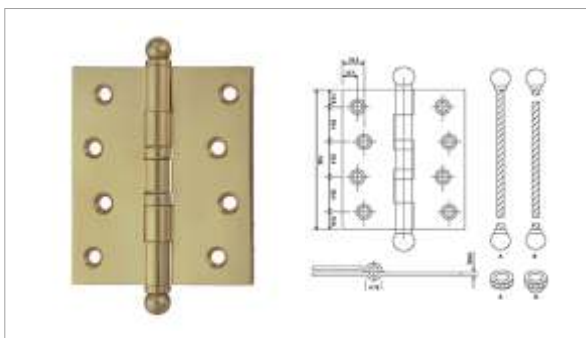

SB404030-2BB-CT

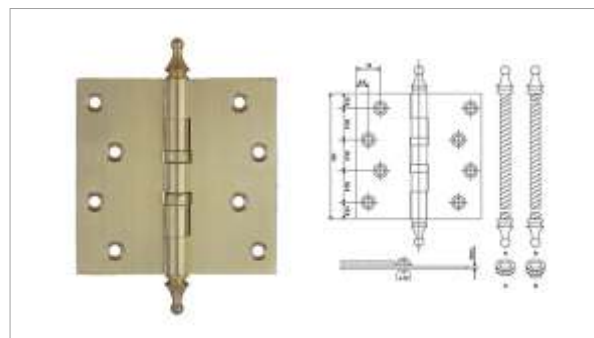

➤ This page product size can be customized.

SB403530-2BB-ST

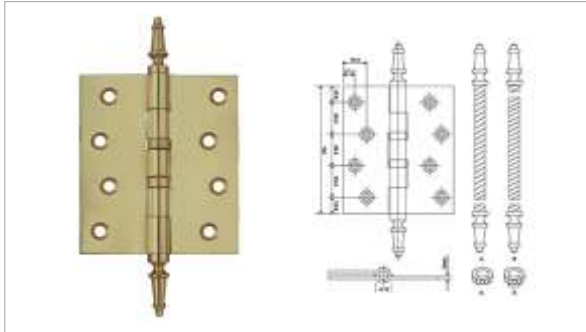

SB403530-4BB-PT

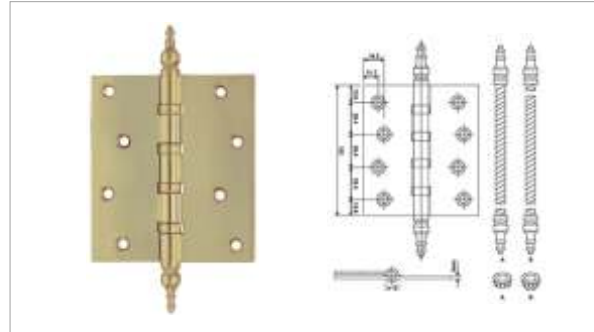

BR-DAS201-4"

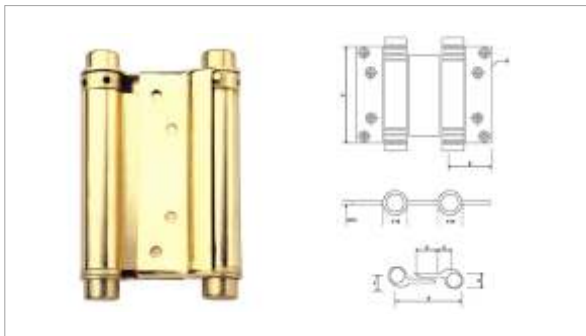

SB404030-S1

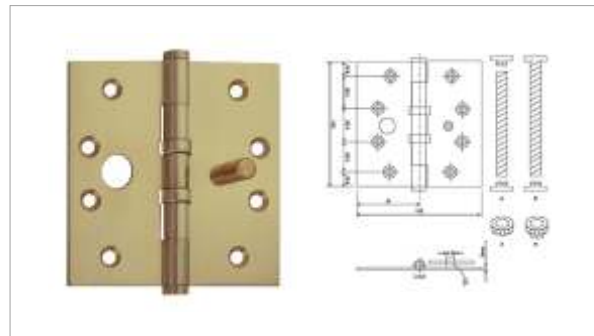

SB404030-S2

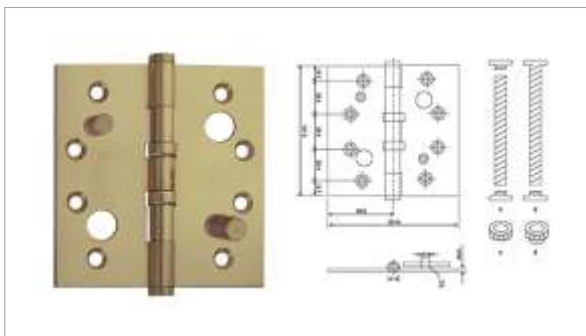

SB403030-CK1

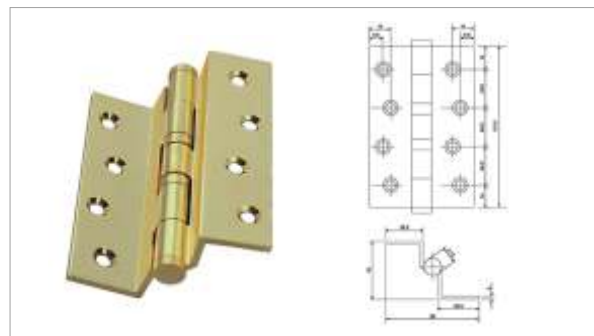

SB353530-PJ-RC

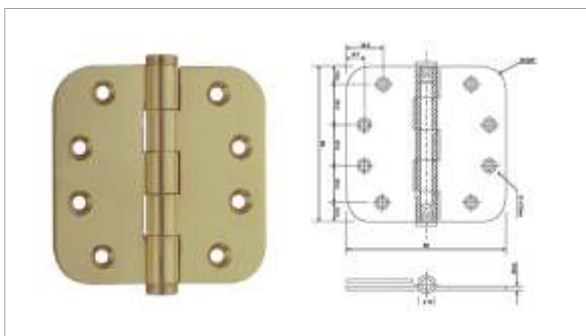

SB404040-P

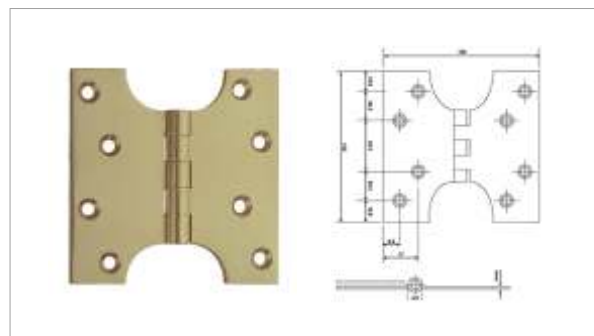

➤ This page product size can be customized.

SB-1



Model No.	Dimension (H x W x T)
SS-CH-1"	25.4 x 1830 x 1mm
SS-CH-1 $\frac{1}{4}$ "	32 x 1830 x 1mm
SS-CH-2"	50.4 x 1830 x 1.2mm
SS-CH-3"	76 x 1830 x 1.2mm

SB-2



Model No.	Dimension (H x W x T)
SB-CH-1"	25.4 x 1830 x 1mm
SB-CH-1 $\frac{1}{4}$ "	32 x 1830 x 1mm
SB-CH-2"	50.4 x 1830 x 1.2mm

SB-IH-01-04



Model No.	Dimension
SB-IH-01	10mm
SB-IH-02	12mm
SB-IH-03	14mm
SB-IH-04	16mm
SB-IH-05	18mm
SB-IH-06	24mm

ZA-CC07

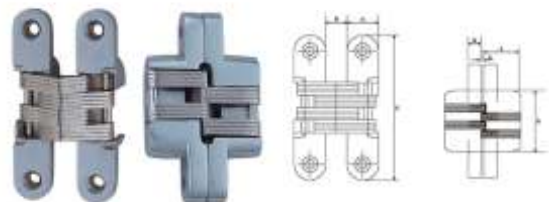

SG-HC3040

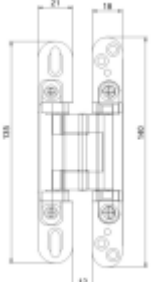
SG-HC4060

SG-HC50120

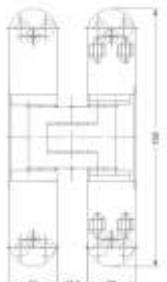

SG-HC101

➤ This page product size can be customized.

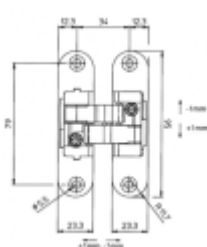

Mortise Lock & Cylinder

- 3-1: Mortise Lock
- 3-2: Cylinder
- 3-3: America Style Brass Handle



LOCK CASES



STANDARDS

CLASSIFICATIONS

DIN EN 1303 - CYLINDERS FOR LOCKS

The cylinders that JinCheng Solutions supply all comply with DIN EN 1303 where applicable.

Digit 1 - Category of use

1 category is identified.

Grade 1 For use by people with a high incentive to exercise care and with a small chance of misuse.

Digit 2 - Durability

3 grades are identified according to the number of test cycles achieved.

Grade 4 25 000 cycles

Grade 5 50 000 cycles

Grade 6 100 000 cycles

Digit 3 - Door mass

No requirement

Digit 4 - Fire resistance

2 grades are identified.

Grade 0 Not suitable for fire/smoke resistant door assemblies

Grade 1 Suitable for fire/smoke resistant door assemblies subject to satisfactory assessment of the contribution of the cylinder to the fire resistance of the specified fire/smoke door assemblies. Such assessment is beyond the scope of this European standard (see EN 1634-1:2014), it must be possible to demonstrate compliance with the Essential Requirements of the Construction Products (Amendments) Regulations.

Digit 5 - Safety

No requirement

Digit 6 - Corrosion and temperature resistance

4 grades are identified.

Grade 0 No corrosion or temperature resistance requirement

Grade A EN 1670 grade 3 corrosion resistance (96 H NSS)
No temperature resistance requirements

Grade B No corrosion resistance: resistance to -20/+80 C temperature extremes

Grade C EN 1670 Grade 3 corrosion resistance: resistance to -20/+80 temperature extremes

Note. No distinction is made between the inside and the outside of either the cylinder and/or the door. On completion of the test, the cylinder must operate.

Digit 7 - Key related security

Consists of a combination of several requirements

Grade	Min. number of effective different key changes	Min. number of moving pins/tumblers
1	100	2
2	300	3
3	15.000	5
4	30.000	5
5	30.000	6
6	100.000	6

Note

Various safety mechanisms integrated in the locking cylinder



Digit 3 - Door mass and closing force

9 grades are identified with maximum figures for closing force at various door masses.

Note: Closing force is from a standing start i.e. fully extended latch bolt in contact with striking plate at start of test.

Digit 4 - Fire resistance

2 grades are identified

Class 0: Not approved for use on fire / smoke doors

Class 1: Allowable for use on fire / smoke doors

The class 1 classification means only that the lock has been designed for use on fire/smoke control doors. The actual fire test approval will be contained in a separate fire test report.

Digit 5 - Safety

No requirements

Digit 6 - Corrosion resistance

8 grades are identified

Class 0: No defined corrosion resistance. No defined temperature

Class A: Low corrosion resistance, no defined temperature

Class B: Mild corrosion resistance, no defined temperature

Class C: High corrosion resistance, no defined temperature

Class D: Very high corrosion resistance, no defined temperature

Class E: Mild corrosion resistance, temperature requirement between -20°C - +80°C

Class F: Very high corrosion resistance, temperature requirement between -20°C - +80°C

Class G: Very high corrosion resistance, temperature requirement between -20°C - +80°C

Digit 7 - Security and drill resistance

7 grades are identified with minimum figures for requirements relating to physical attack - with or without drilling of the lock case.

Class 1: Min. anti-burglary effect without drill resistance

Class 2: Low anti-burglary effect without drill resistance

Class 3: Mild anti-burglary effect without drill resistance

Class 4: High anti-burglary effect without drill resistance

Class 5: High anti-burglary effect with drill resistance

Class 6: Very high anti-burglary effect with drill resistance

Class 7: Very high anti-burglary effect with drill resistance

Digit 8 - Field of door operation

15 grades are identified for differing applications. The grading determines which application is appropriate.

Digit 9 - Key operation and locking

9 grades are identified for differing types of key operations.

The grading determines how the lock is assessed for deadlocking requirement as shown. In addition, there is a maximum key torque operating requirements of 1,5Nm and a minimum key strength requirement of 2,5Nm.

Class 0: not applicable

Class A: cylinder lock manual locking mechanism

Class B: cylinder lock automatic locking mechanism

Class C: cylinder lock manual locking mechanism with in-between locking

Class D: chubb lock manual locking mechanism

Class E: chubb lock automatic locking mechanism

STANDARDS

CLASSIFICATIONS

Class F: chubb lock manual locking mechanism with in-between locking locking

Class G: lock without key operation manual locking mechanism

Class H: lock without key operation automatic locking mechanism

Digit 10 - Spindle operation

5 grades are identified

Class 0: lock without hub

Class 1: lock for handle or knob operation with durable spring

Class 2: lock for handle operation without durable spring

Class 3: lock for knob operation with higher stress and heavy durable spring

Class 4: lock for special handle operation (designed by producers) with higher stress and heavy durable spring

Digit 11 - Key identification

9 grades are identified relating to the number of tumblers and levers. Grade 0 relates to a latch with no locking action.

Class 0: no indicated requirements

Class A: at least 3 tumblers

Class B: at least 5 tumblers

Class C: at least 5 tumblers with extended locking disparities

Class D: at least 6 tumblers

Class E: at least 6 tumblers with extended locking disparities

Class F: at least 7 tumblers

Class G: at least 7 tumblers with extended locking disparities

Class H: at least 8 tumblers with extended locking disparity

TYPE OF DOOR

The choice of mortise lock also depends on the type of the door:

Profile of a rebated door with mortise lock (forend protruding at one side)

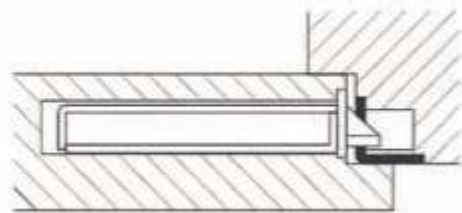

Profile of a flush door with mortise lock (forend protruding at both sides)

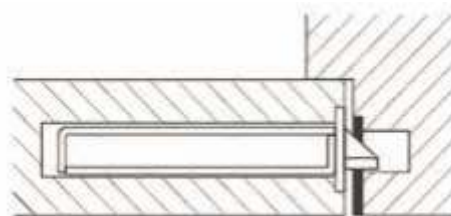

STANDARDIZATION IN COMPLIANCE WITH DIN

Mortise locks can be tested according to DIN 18251 and assigned to 5 lock categories:



STANDARDIZATION IN COMPLIANCE WITH DIN

Mortise locks can be tested according to DIN 18251 and assigned to 5 lock categories:

Grade 1

- Lock for interior doors (interior door lock for infrequently used door)
- Backset 55 mm
- Lock cover secured in two places
- Max. door weight 40 kg *)
- Infrequent use

Grade 2

- Lock for more frequently used interior doors (interior door lock)
- Backset 55 mm
- Lock cover secured in at least two places
- Door weight 40 - 50 kg *)
- Standard use

Grade 3

- Lock for external apartment doors
- Backset 55 mm
- Lock cover secured in at least three places
- Door weight 50 - 60 kg *
- Moderate use
- Type tested according to DIN 18257 with firmly ed fittings with 200,000 latch bolt operations and 50,000 deadbolt operations

Grade 4

- Lock for high user frequency and increased burglary prevention
- Backset 55 mm - 100 mm
- Lock cover secured in at least three places
- Door weight greater than 50 - 60 kg *
- Frequent use
- Type tested according to DIN 18257 with firmly ed fittings with 500,000 latch bolt operations and 100,000 deadbolt operations

Grade 5

- Lock for high user frequency and increased burglary prevention
- Backset 55 mm - 100 mm
- Lock cover secured in at least three places
- Door weight greater than 60 kg *
- Frequent use
- Type tested according to DIN 18257 with firmly ed fittings with 500,000 latch bolt operations and 100,000 deadbolt operations

*The door weight refers to a standard door with size 2 x 1 m

ML003-A-1

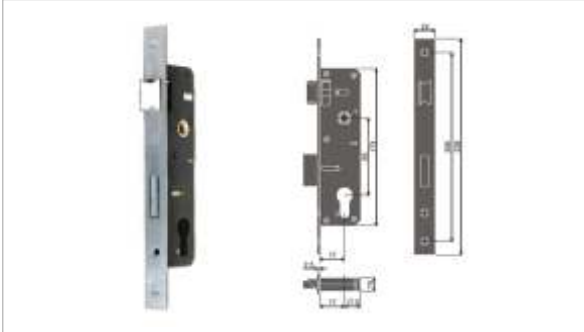

ML003-A-2

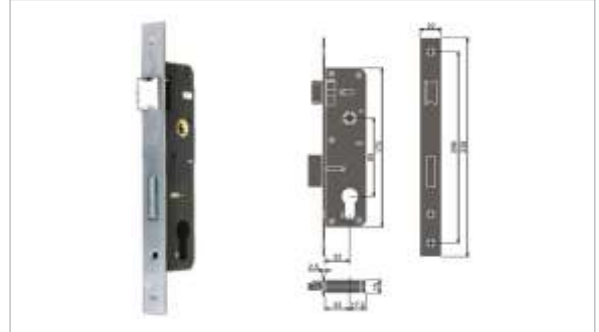

ML003-A-3

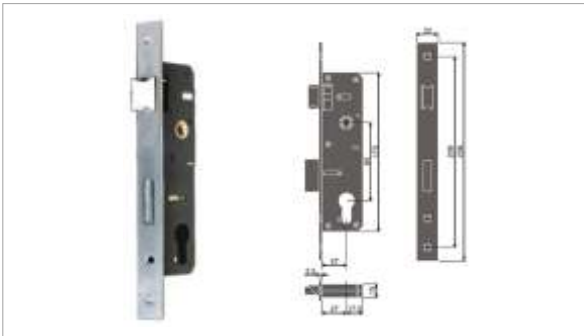

ML003-A-4



ML003-B-2

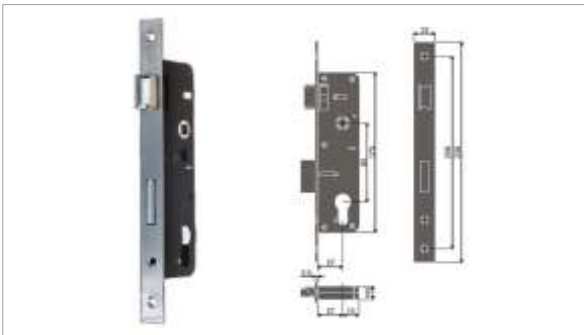

ML003-B-3

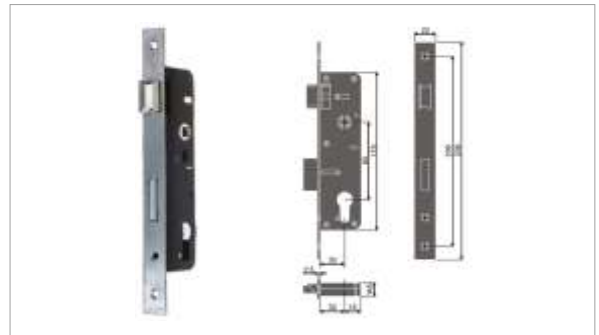

ML003-C-1

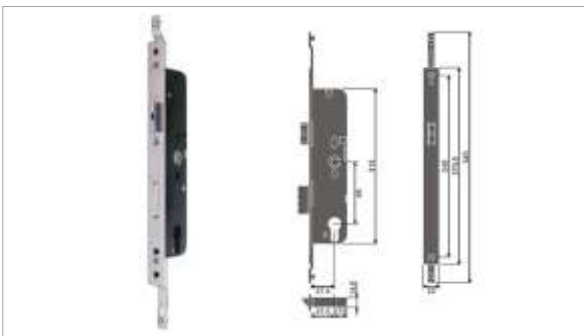

ML003-C-2

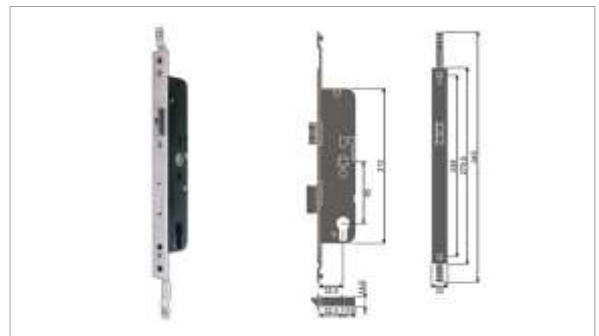

➤ This page product size can be customized.

ML001-E

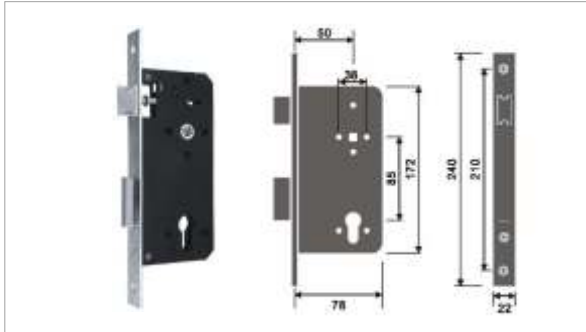

ML001-B

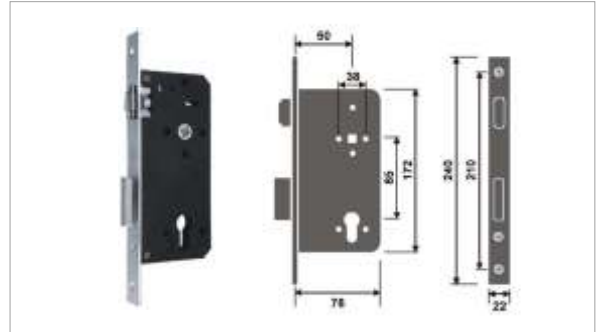

ML001-P

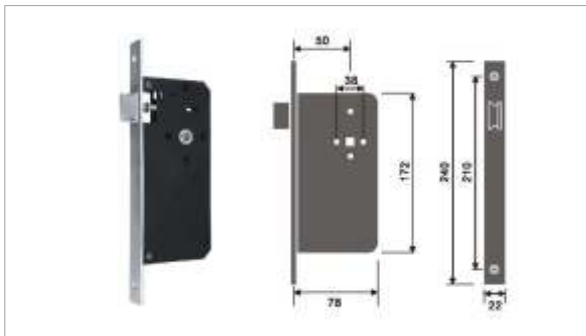

ML001-B-2

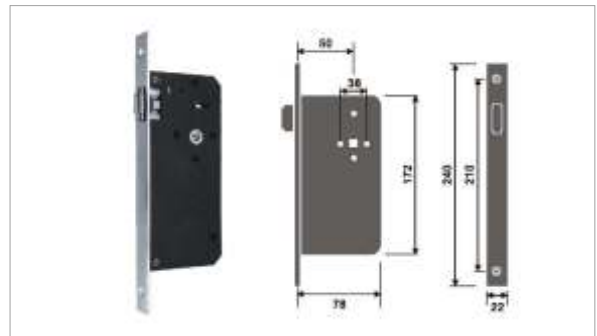

ML001-WC-2

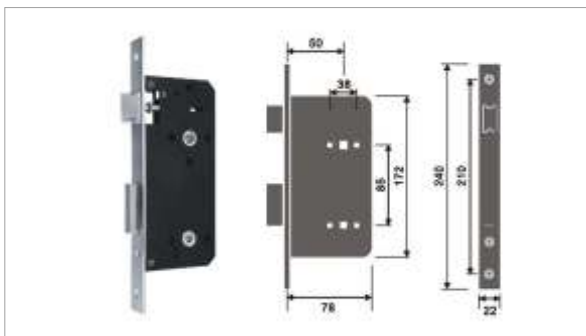

ML001-WC-3

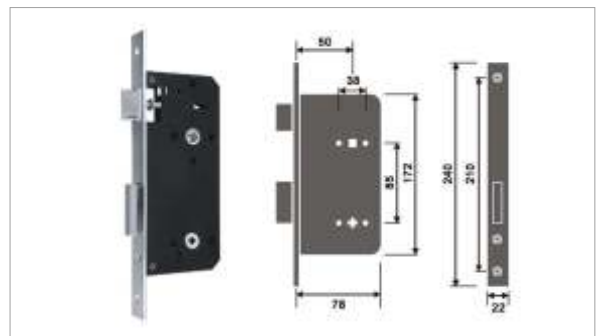

ML001-P-2

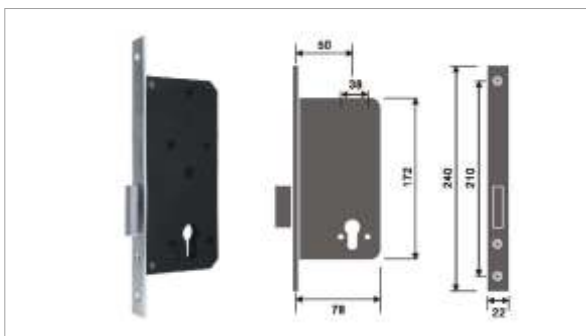

ML001-F

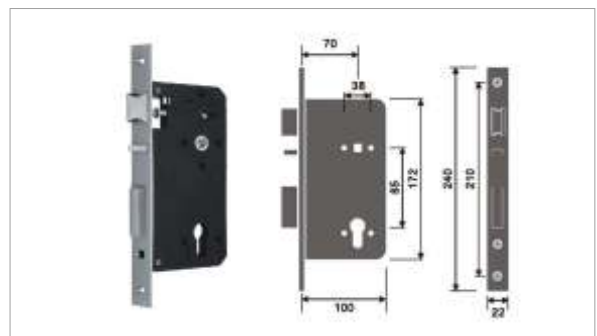

➤ This page product size can be customized.

ML012-18

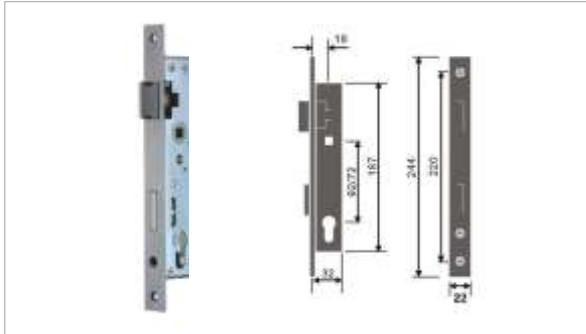

ML012-20

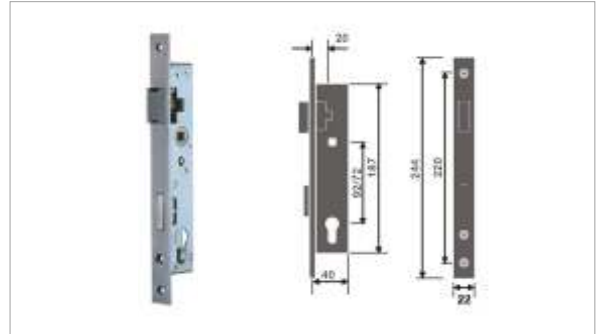

ML012-22

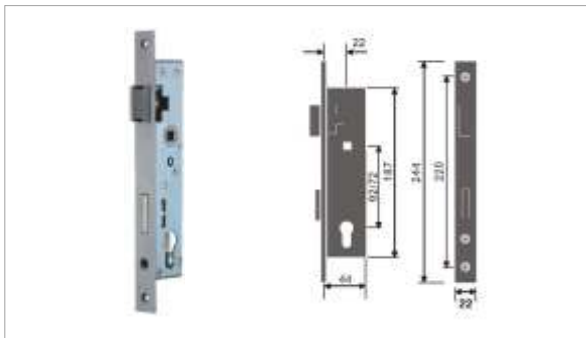

ML012-24

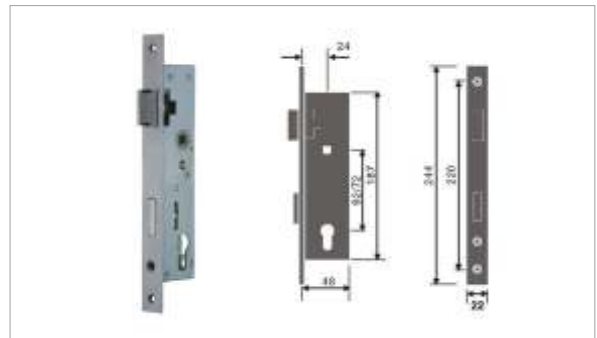

ML012-30

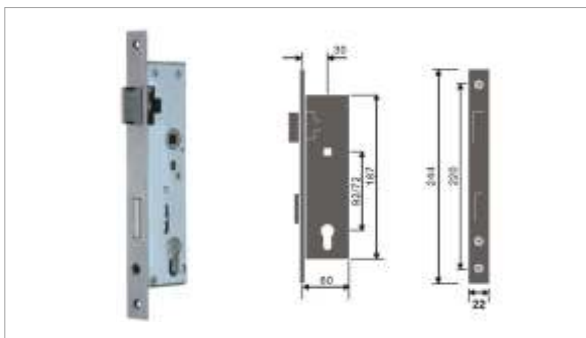

ML002-E

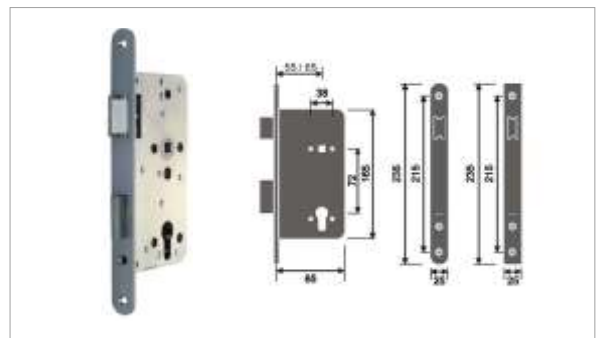

ML002-B

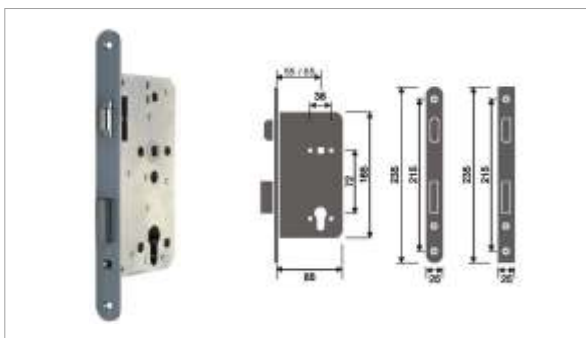

ML002-P

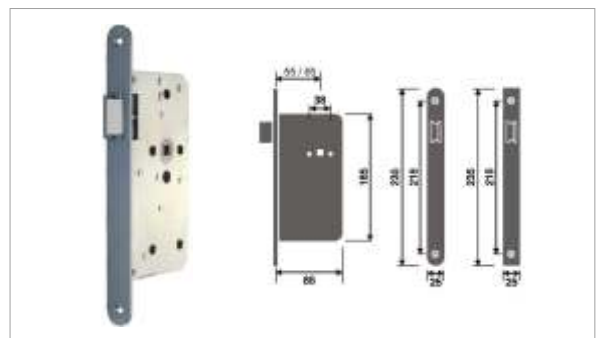

➤ This page product size can be customized.

ML002-B-2

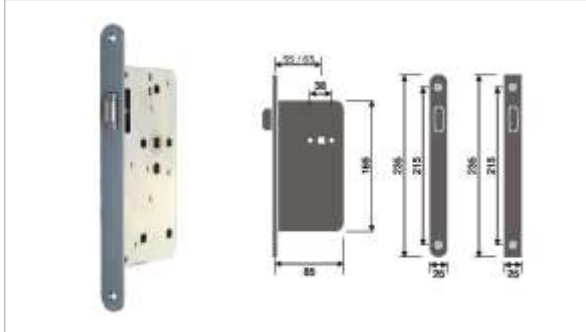

ML002-WC-2

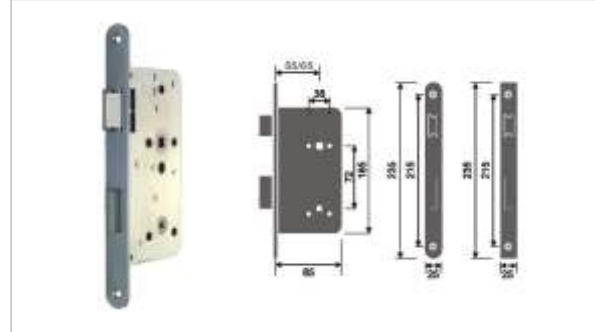

ML002-WC-3

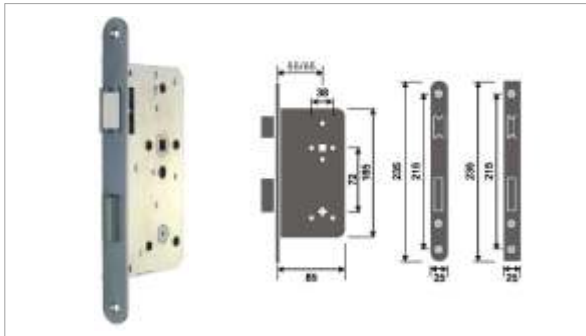

ML002-P-2

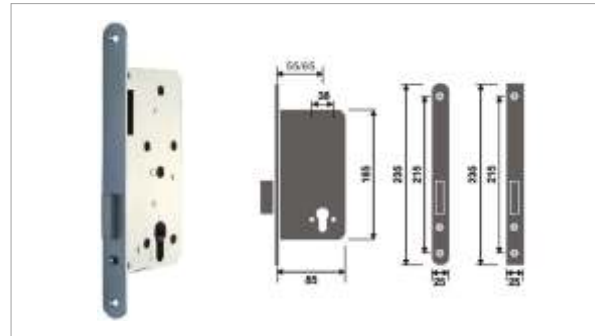

ML002-E-92

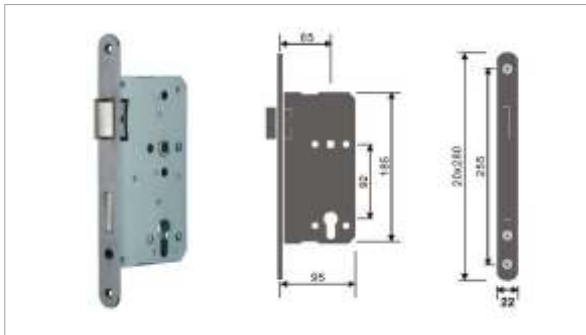

ML002-F

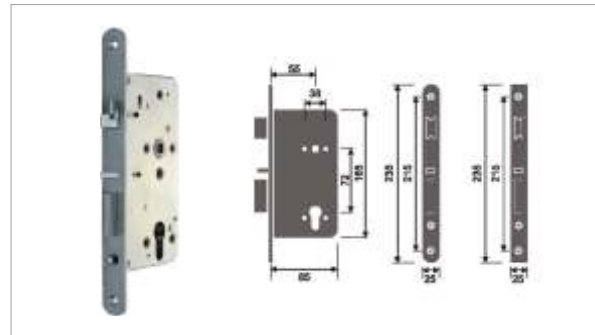

ML011-E

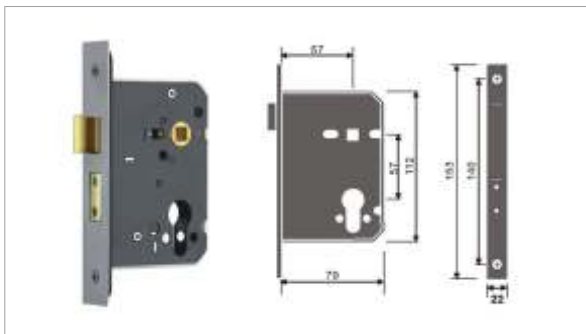

ML011-B

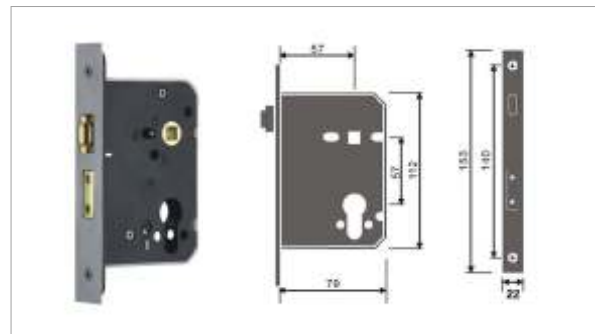

➤ This page product size can be customized.

ML011-P

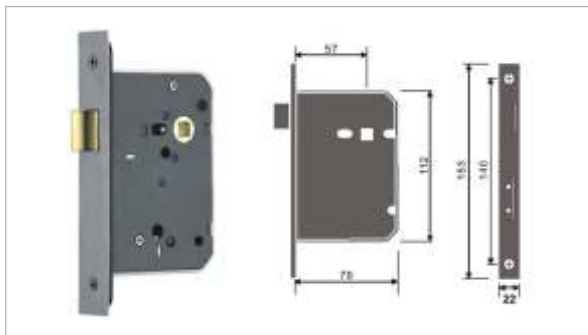

ML011-B-2



ML011-WC-2

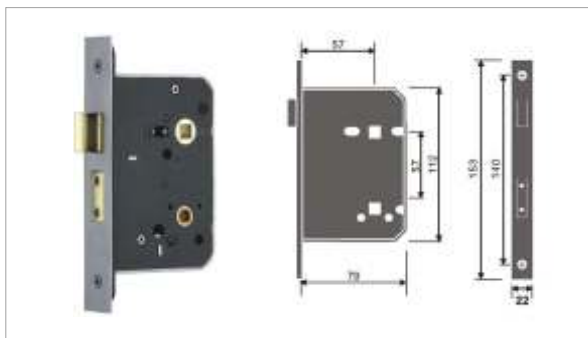

ML011-WC-3

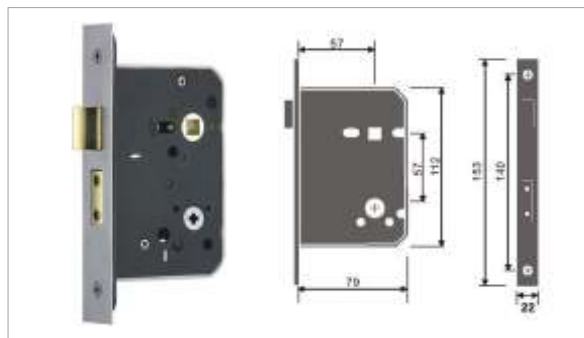

ML011-P-2

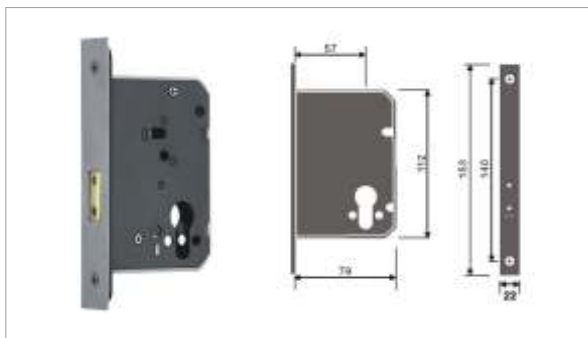

ML005-E

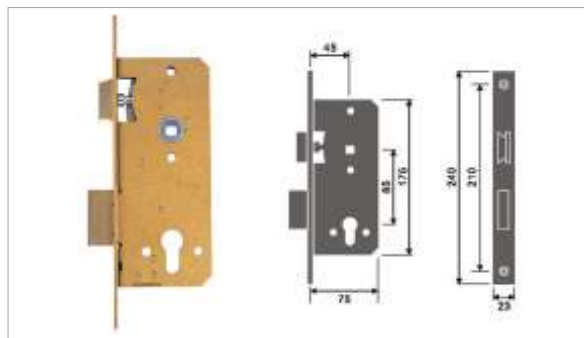

ML006-E

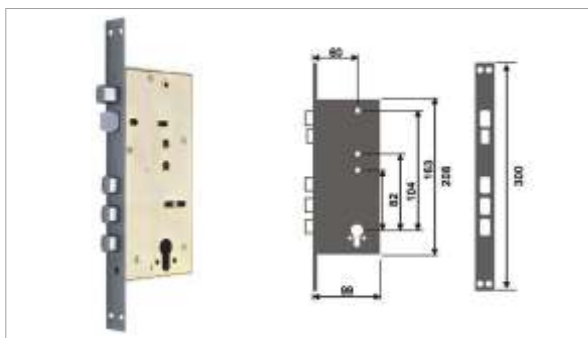

ML008-P

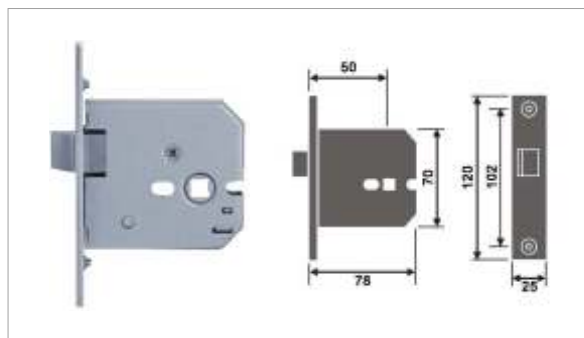

➤ This page product size can be customized.

ML010-S

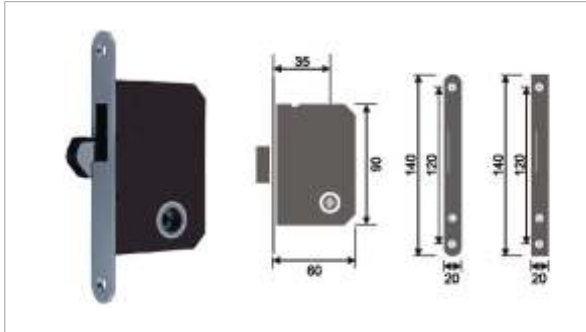

ML004-E

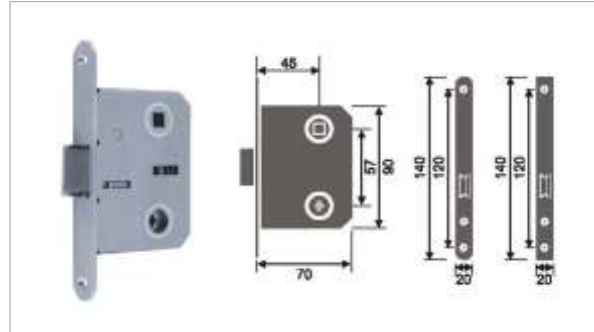

ML004-WC-2

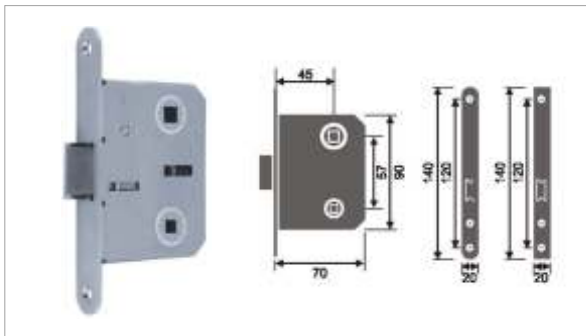

ML004-P

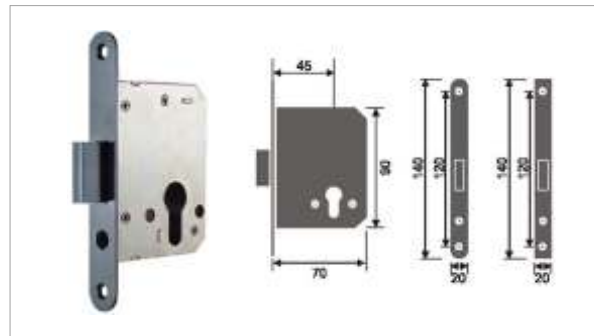

ML004-P-2

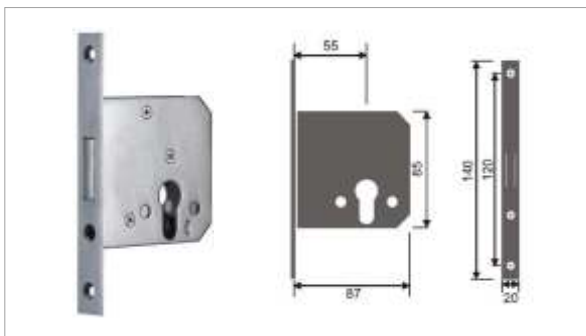

ML013-A

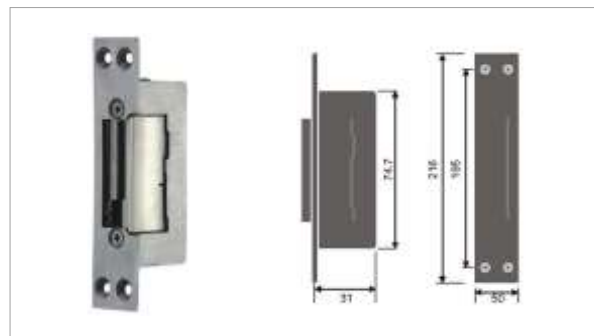

ML013-B

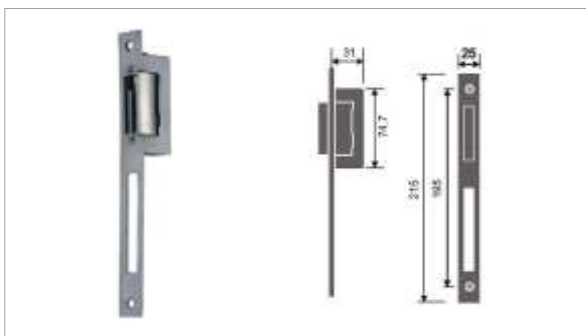

RK-001

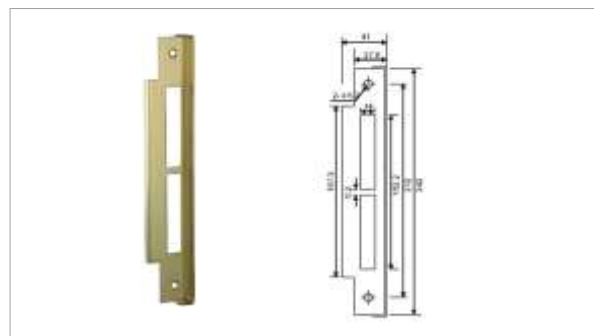

➤ This page product size can be customized.

72ZD

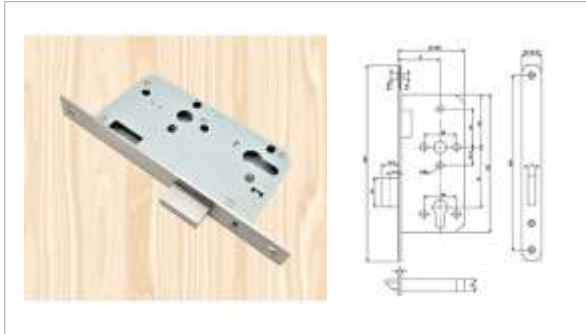

78ZWC

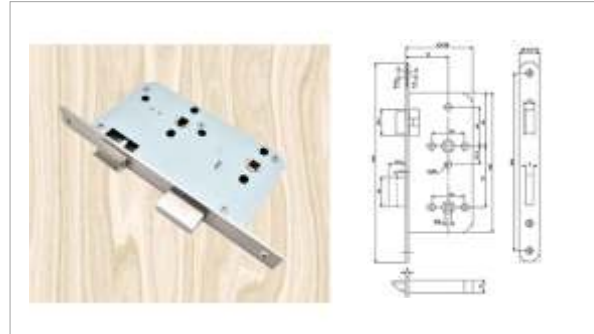

72CR

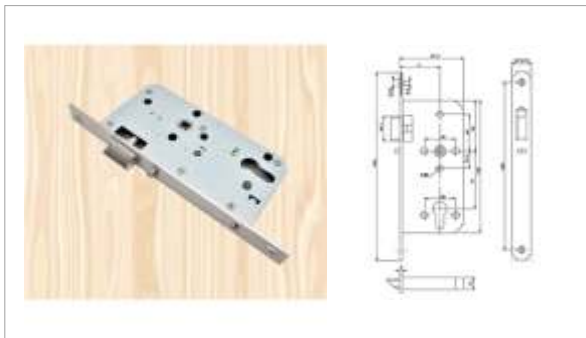

72ZR

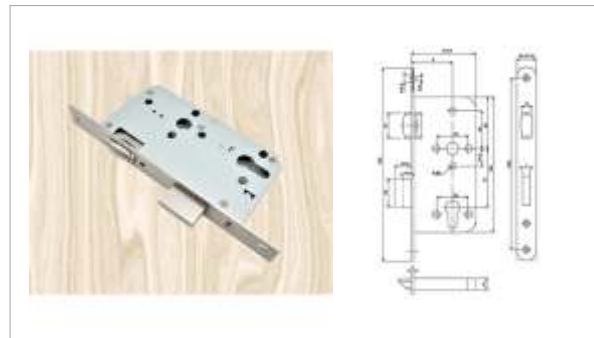

A72Z

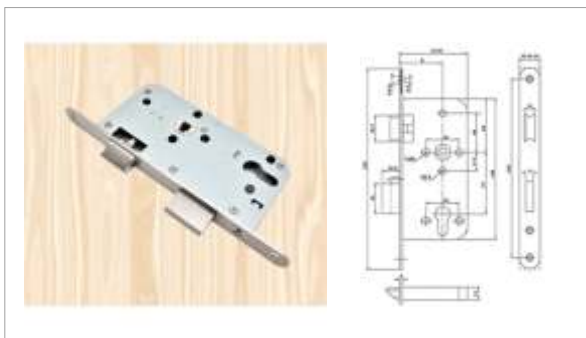

72Z

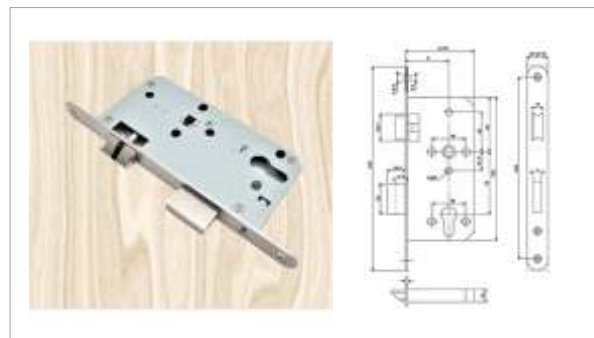

6572DC

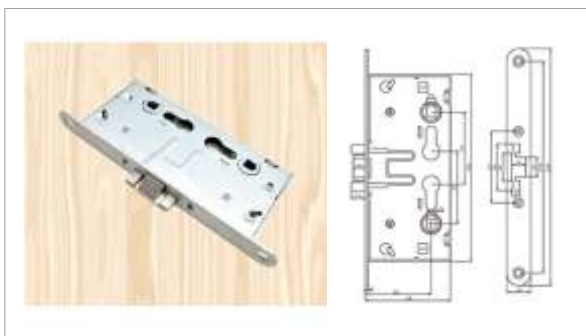

85Z

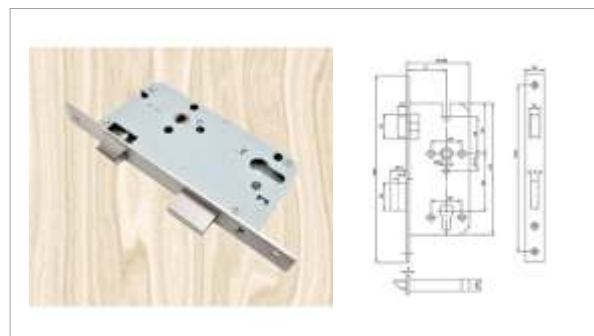

➤ This page product size can be customized.

85Z-3M

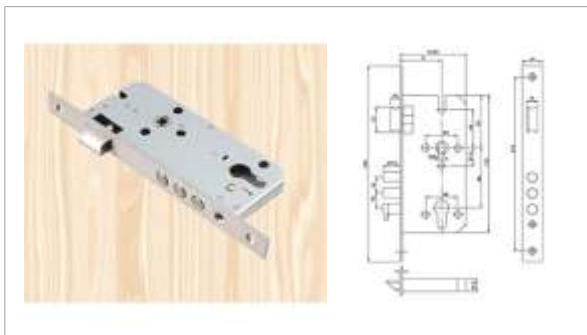

85R

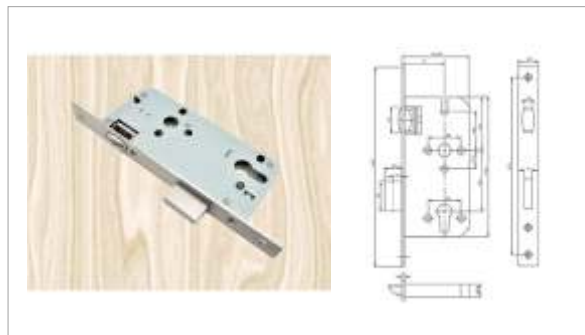

50SD

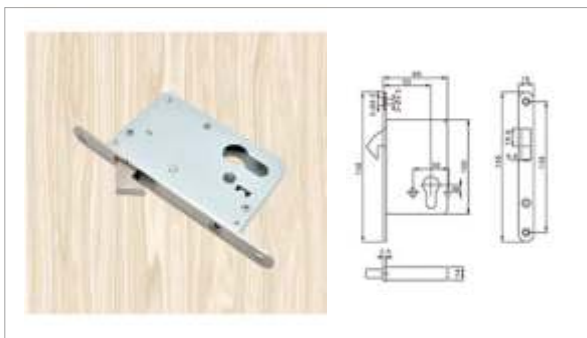

50S

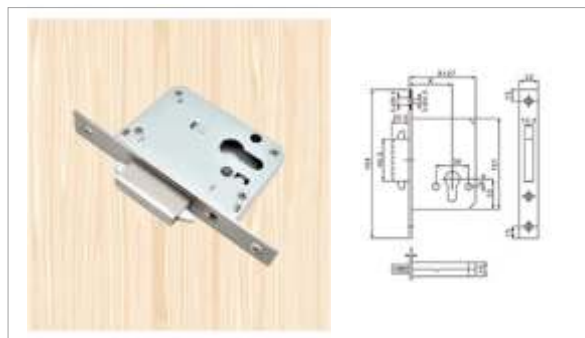

55ZL

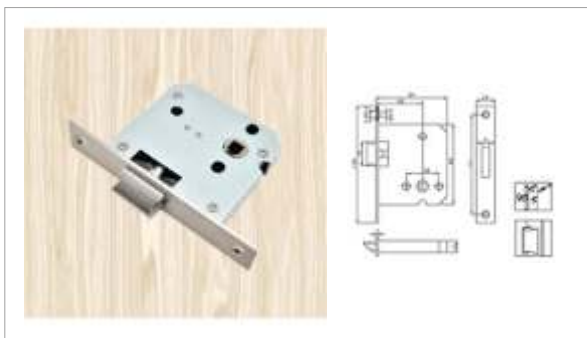

55ZD

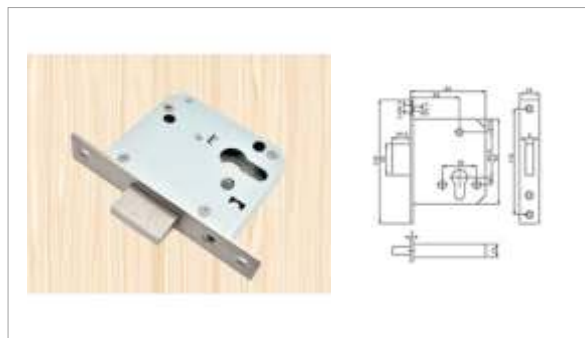

55ZR

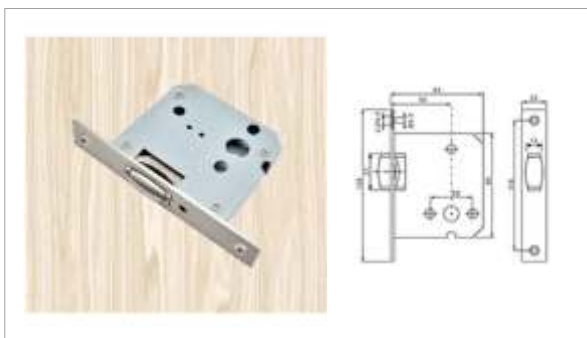

55ZWC

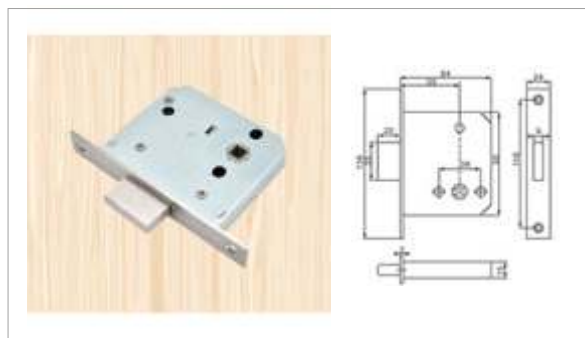

➤ This page product size can be customized.



CYLINDERS



STANDARDS

CLASSIFICATIONS

JinCheng Solutions offers a large range of different lock cases to support the entire range of door levers, knobs, sliding hardware and other unsprung hardware furniture. Quality, security and tested performance goes hand in hand. Lock cases are tested and classified according to DIN EN 12209.

DIN EN 12209 - BUILDING HARDWARE

This standard is valid for mechanically operated locks and their strike plates that can be installed in the doors, windows and entrance doors.

The standard specifies testing procedures and requirements with regard to:

- Durability
- Strength
- Protection effect
- Effectiveness

The current DIN EN 12209 was published in March 2004 and has the status of a national standard. Annex A (fire resistance requirements) - this standard is harmonized and must be used in Europe.

The standard stipulates that all products tested should be classified in accordance with an 11-digit-system.

Digit 1 - Category of use

3 classes are identified.

Class 1: Used by people with a high incentive to a careful application, where misuse or risks are less possible, e.g. interior residential doors.

Class 2: Used by people with a little incentive to a careful application, where misuse or risks are possible, e.g. office doors.

Class 3: Used by people with a little incentive to a careful application, where misuse or risks are possible, e.g. doors in public buildings.

Digit 2 - Durability

12 grades are identified with minimum figures with deadbolt and sniob operation, and latch bolt operation with and without side load as shown. The side load is applied to the latch bolt when it is being withdrawn.

- Class A: 50,000 tested cycles no stress on latch bolt
- Class B: 100,000 tested cycles no stress on latch bolt
- Class C: 200,000 tested cycles no stress on latch bolt
- Class F: 50,000 tested cycles stress on latch bolt 10 N
- Class G: 100,000 tested cycles stress on latch bolt 10 N
- Class H: 200,000 tested cycles stress on latch bolt 10 N
- Class L: 100,000 tested cycles stress on latch bolt 25 N
- Class M: 200,000 tested cycles stress on latch bolt 25 N
- Class R: 100,000 tested cycles stress on latch bolt 50 N
- Class S: 200,000 tested cycles stress on latch bolt 50 N
- Class W: 200,000 tested cycles stress on latch bolt 100 N
- Class X: 200,000 tested cycles stress on latch bolt 100 N

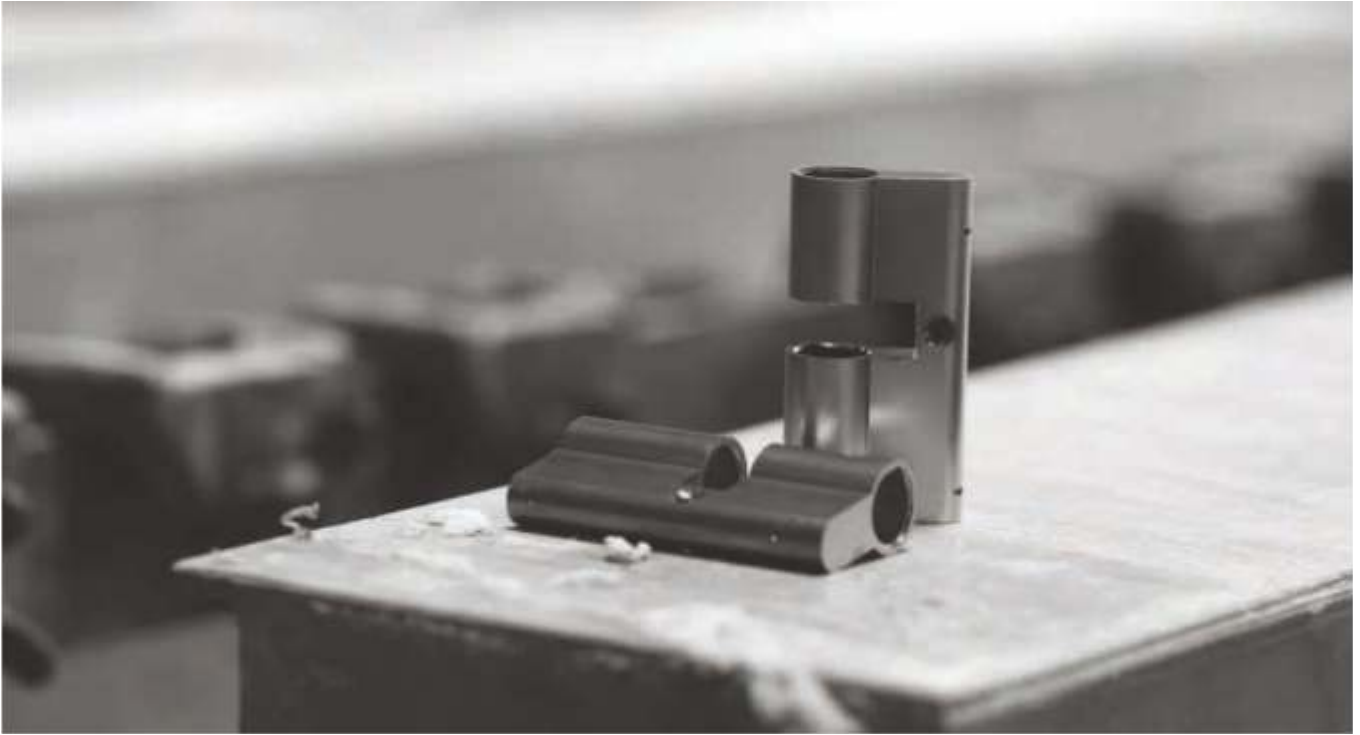

guarantee the maximum safety of a locking cylinder. Apart from a high number of pin tumblers, which reduce the risk of unauthorized unlocking, the following functions in particular prevent a forced opening:

- Drilling protection
- Pull protection

Digit 8 - Attack resistance

Consists of a combination of several requirements.

Grade	0	1	1
Drilling time	-	3/5 min.	5/10 min.
Chissel attack	-	30 blows	40 blows
Twisting attack	-	20 twists	30 twists
Extraction (pull load)	-	15 kN	15 kN
Torque	-	20 Nm	30 Nm

TERMINOLOGY

Locking cylinders are categorized according to:

A: Frontview



Euro profile

B: Sideview

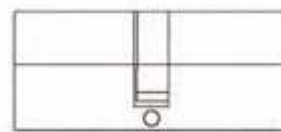

Double cylinder

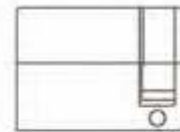

Half cylinder

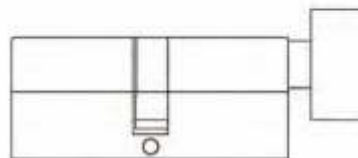

Thumb turn cylinder

The definition of important components and characteristics of locking cylinders in this catalogue follows generally the terminology according to EN 1303 with DIN 18252/09-1999.



MASTER KEY SYSTEMS

Which locking system is the right one for your requirements? Choosing a master key system presents a great challenge to those who make the decision as any differences and benefits can often only be found in a product's technical features. However, choosing a MANUFACTURER is also the beginning of a long partnership as security solutions also stand out because they represent a highly safe investment and are designed for long-term use in a master key system.

How can we best help you in making your decision? The JinCheng cylinders are divided into 4 different levels of security.

MCS PREMIUM+

ICS PREMIUM

EPS ADVANCED

FPS STANDARD

From Standard through to Premium+, the JinCheng Security Pyramid offers a clear classification of the different security levels and serves as a well-defined guide.

You can rely on JinCheng recommendations. Companies from all over the world place their trust in the JinCheng locking systems.

The systems offer a very high level of security right from the ground up. However, requirements regarding security, convenience and organisation are distinct for different industries and building types. As a result of years of experience, we can recommend the locking system which will best meet your company's requirements.

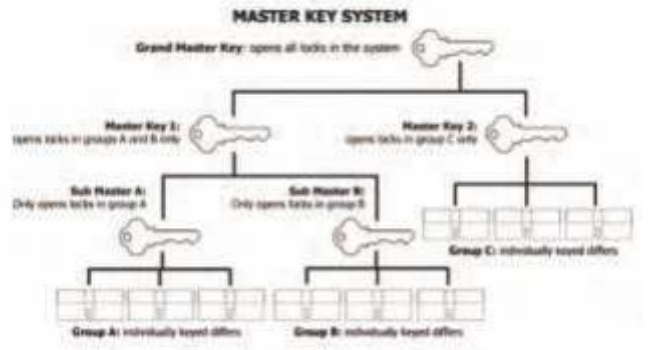

Master keying is commonly used in commercial buildings, where a single key known as the Grand Master key will open all doors within the building. Sub Master key groups can be created that open a selection of doors, and then service keys being individual keys to open specific doors only.

LK101

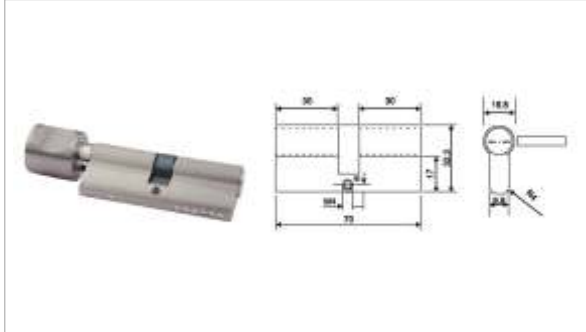

LK102

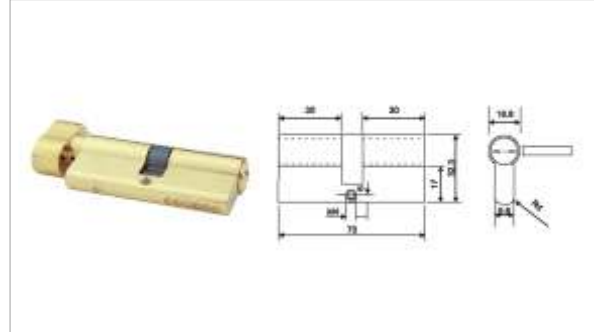

LK103

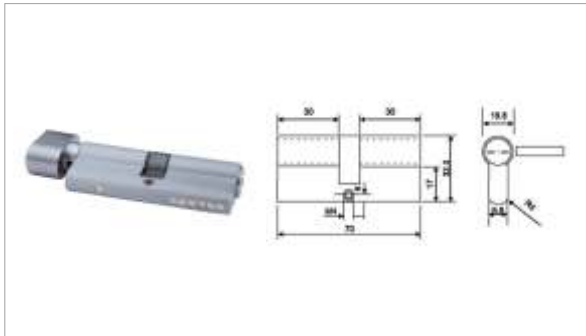

LK104

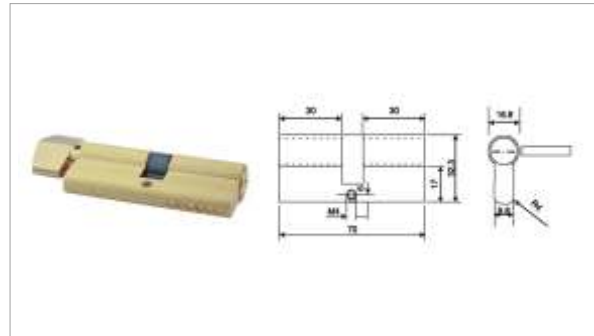

LK105



LK106

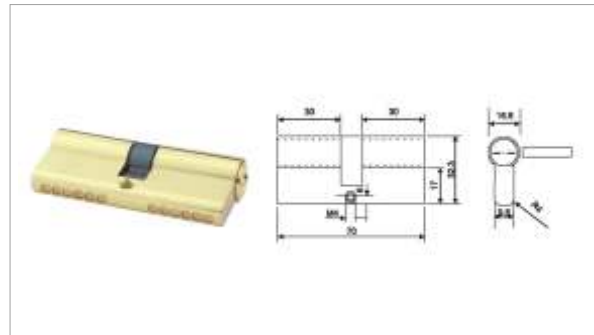

LK107

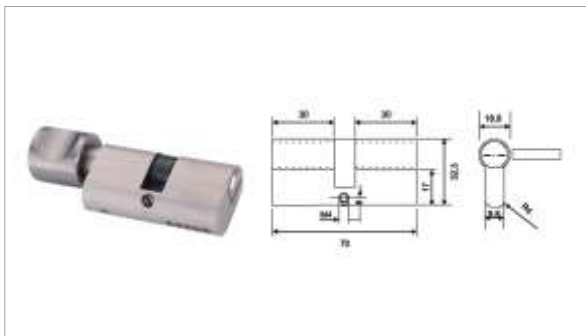

LK108

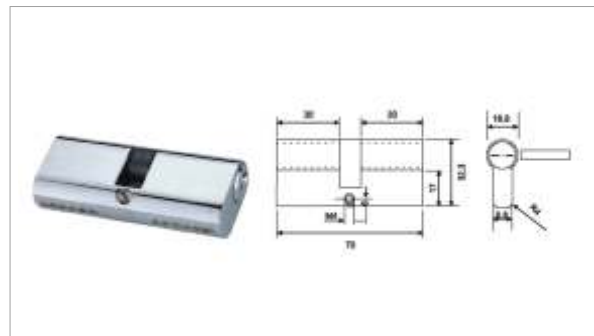

➤ This page product size can be customized.

LK109(security)

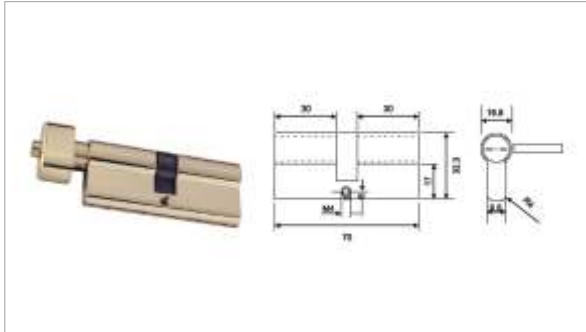

LK110(security)

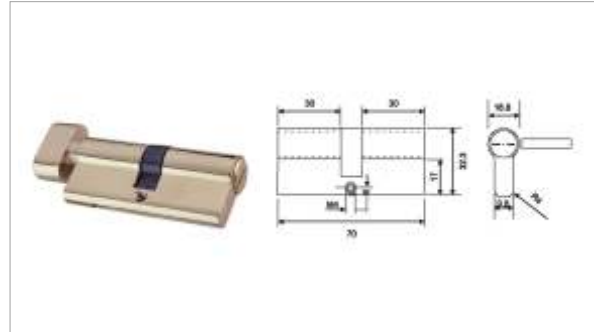

LK111

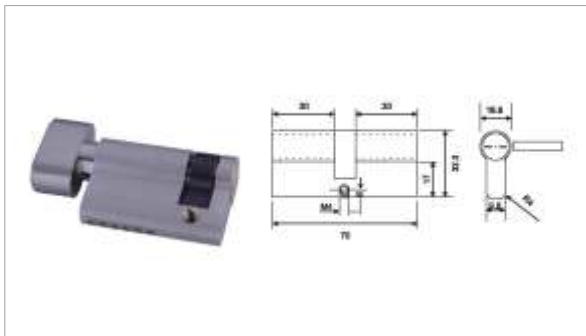

LK112

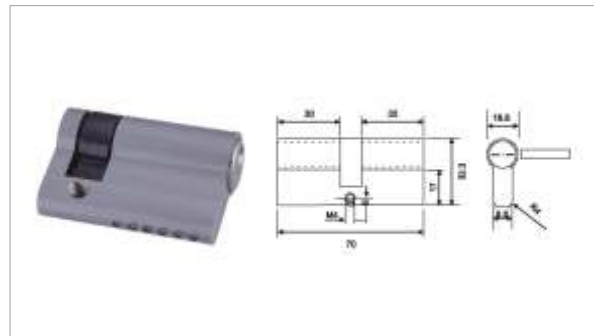

Knob A

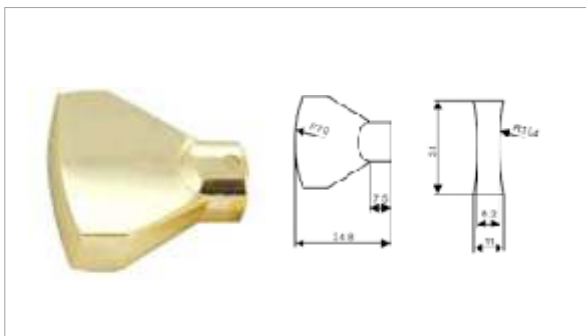

Knob B

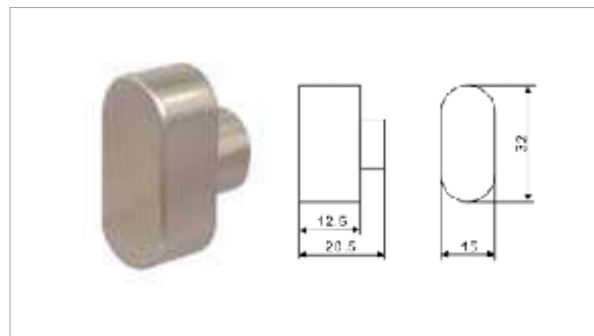

Knob C

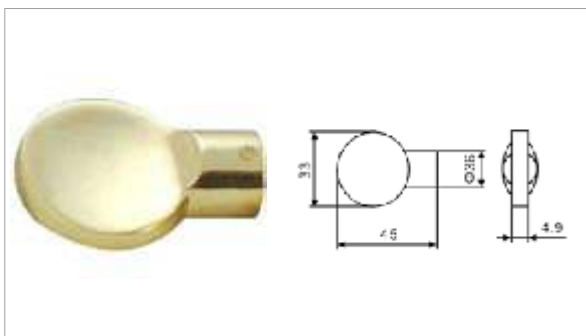

Knob D

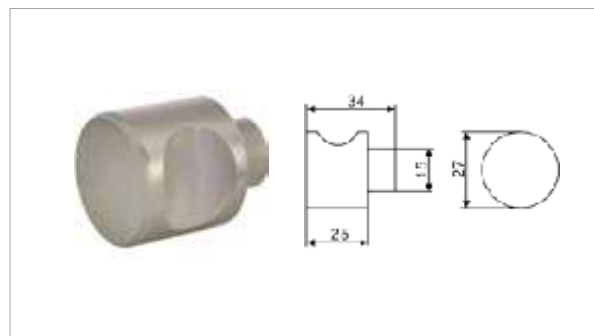

➤ This product size can be customized.

Knob E

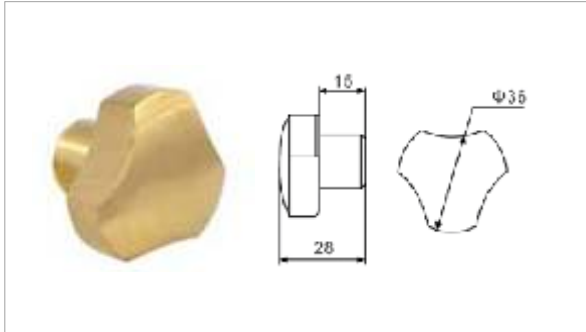

Knob F

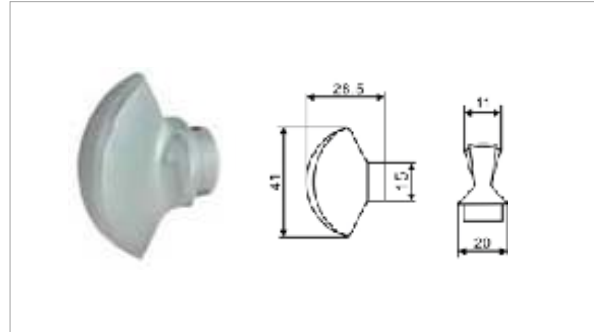

Knob G

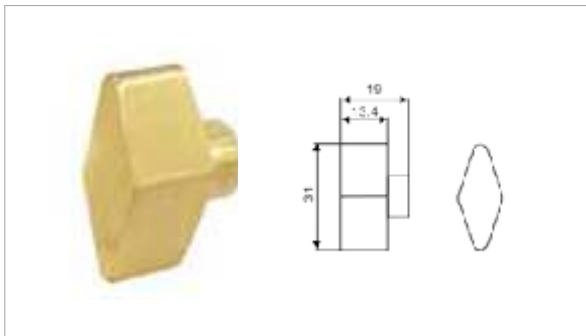

Knob H

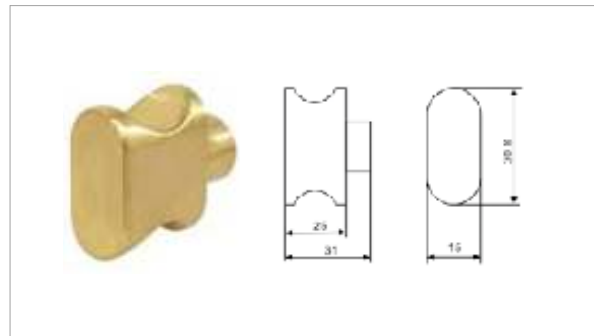

Knob I

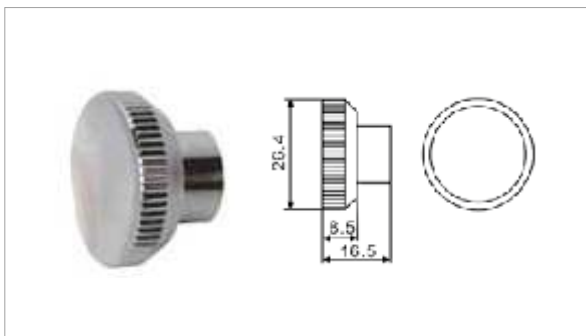

Knob J

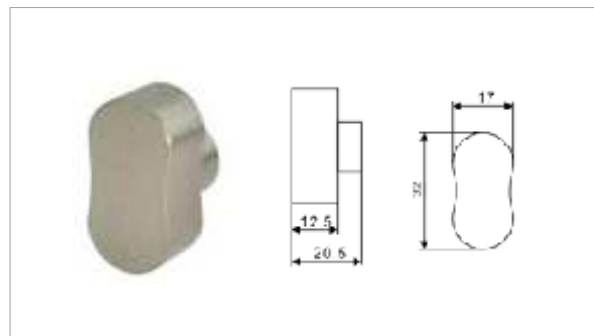

Knob K

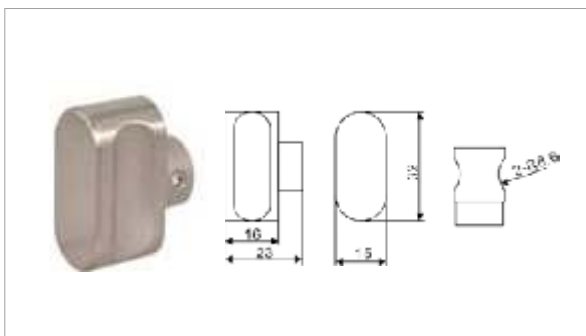

Knob L

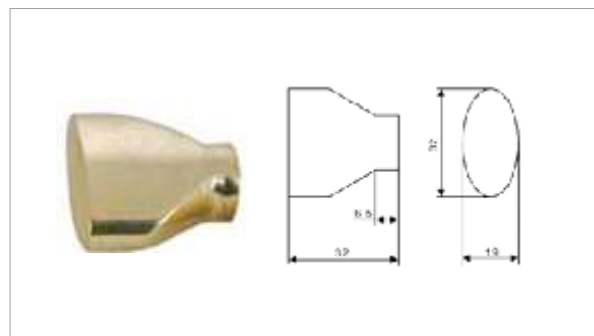

LP501



LP502

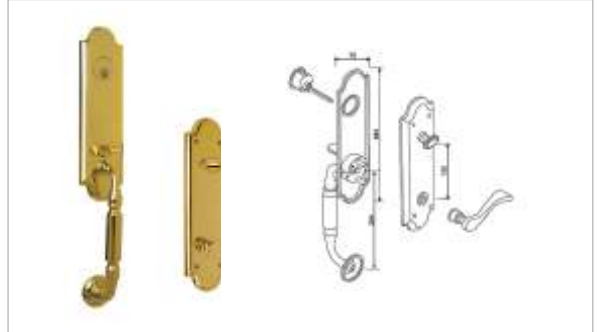

LP503



LP504

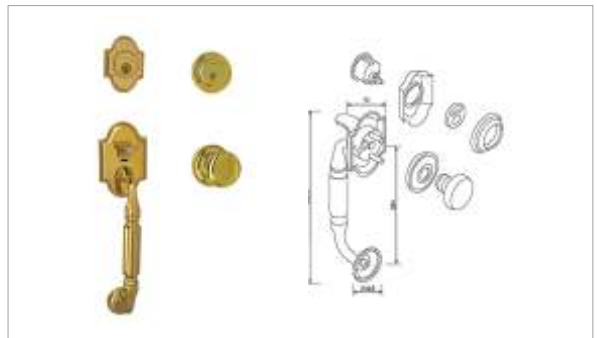

LP505

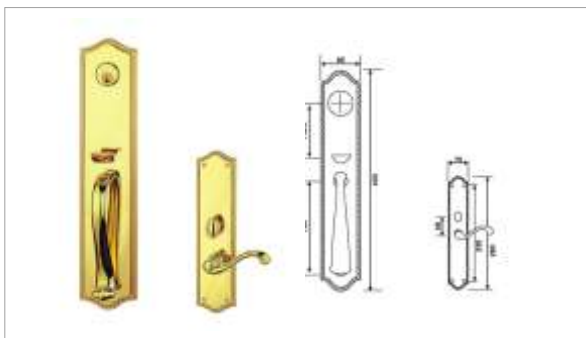

LP506

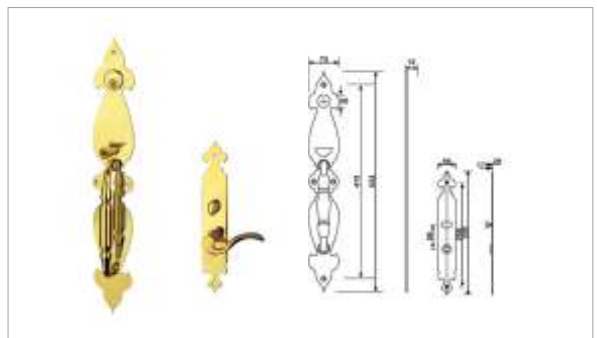

LP507

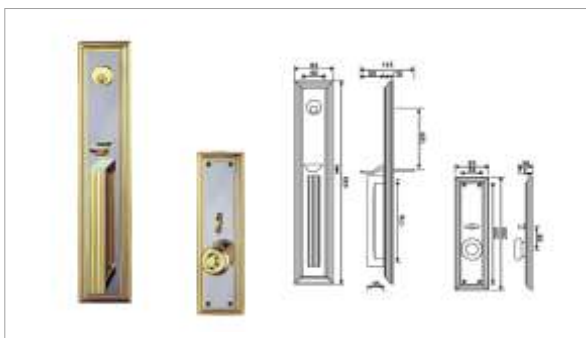

LP508

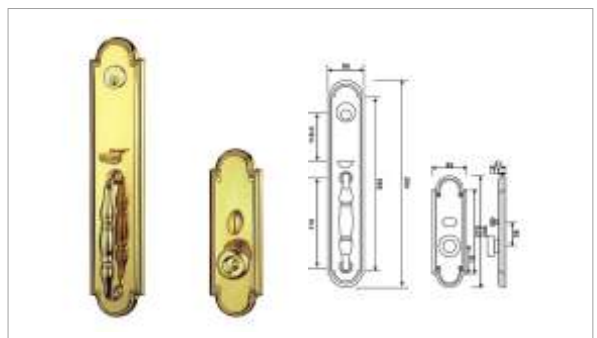

LP509



LP510

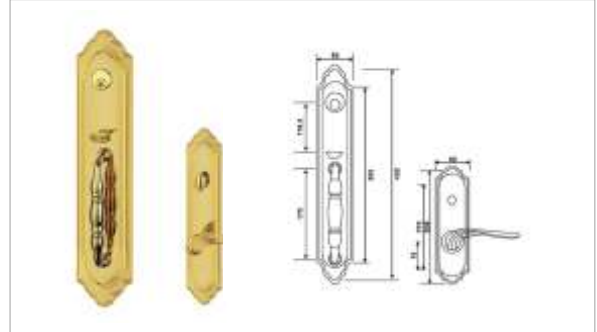

LP511

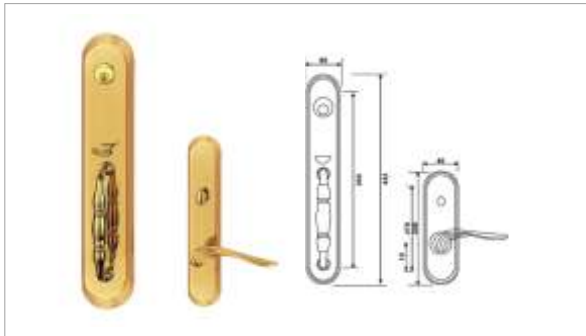

LP512

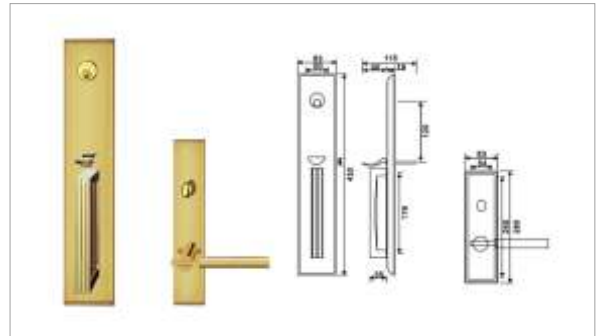

BZAP001

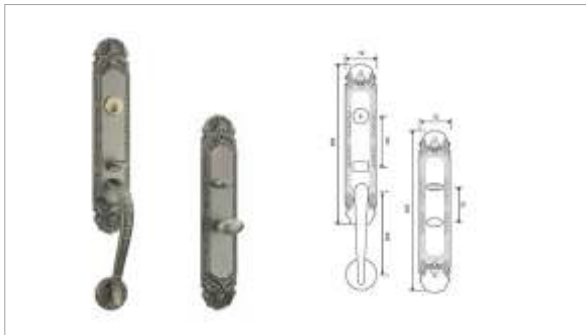

BZAP002

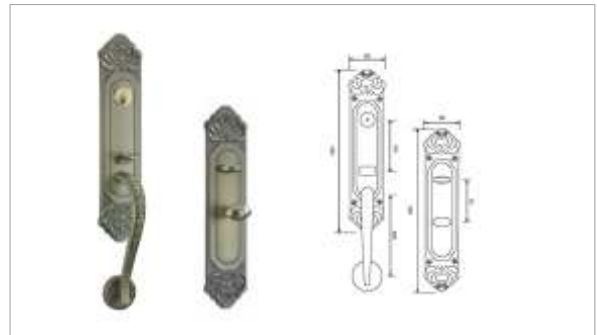

BZAP003



BZAP004

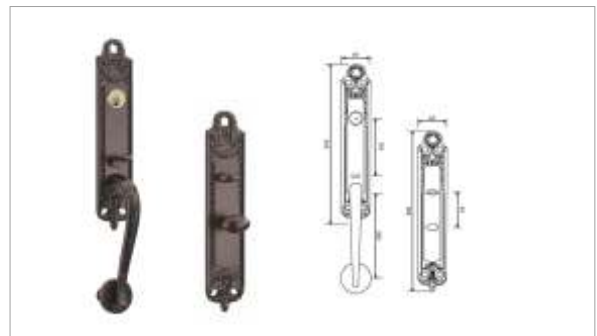

BZAP005

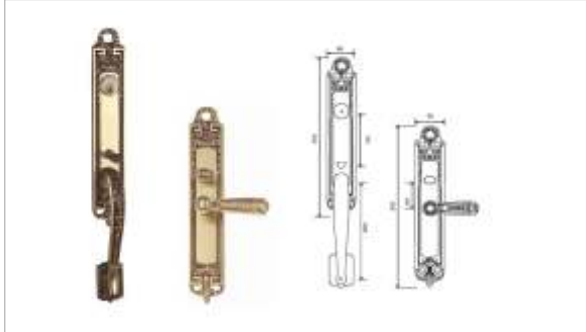

BZAP006



AL001

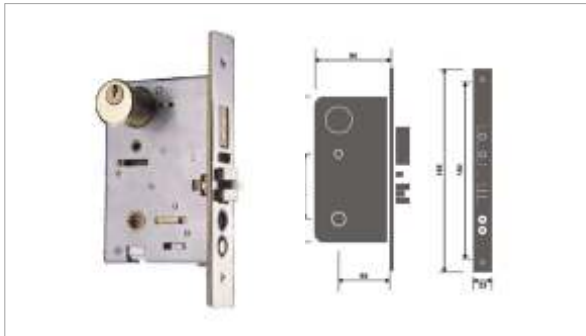

ALC001

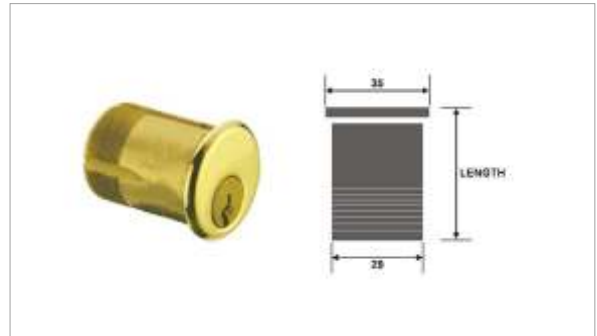

ALC002

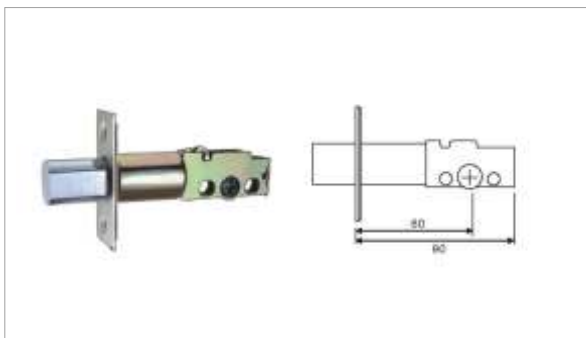



Pull Handle

- 4-1: Hollow(tube)
- 4-2: Solid

PULL HANDLES



PH201

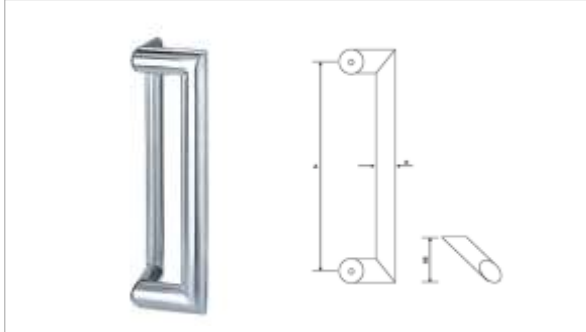

PH202

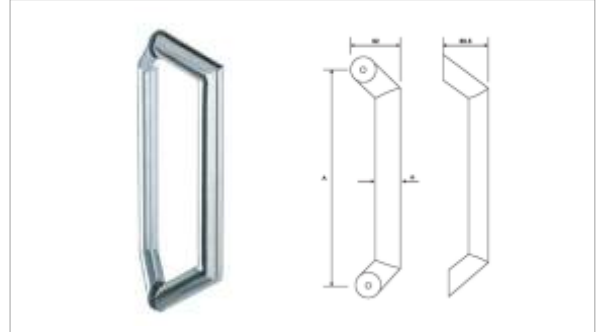

PH203

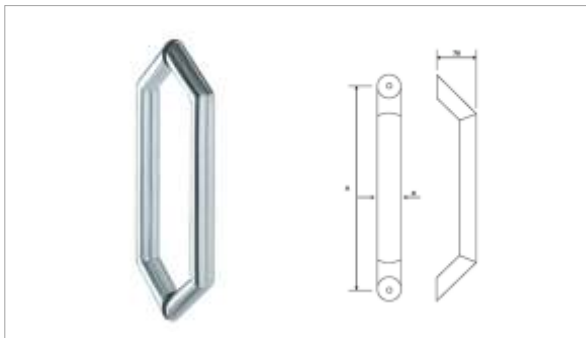

PH204

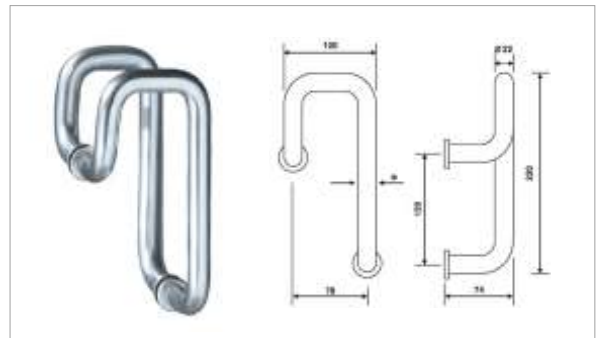

PH205

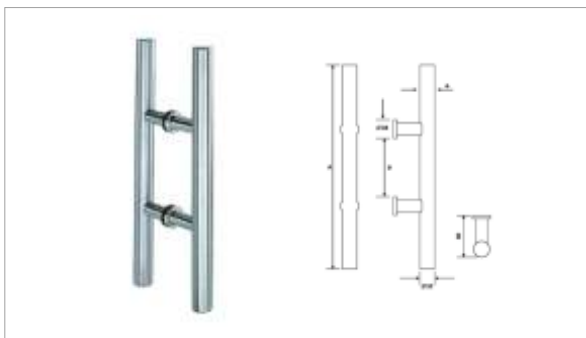

PH206

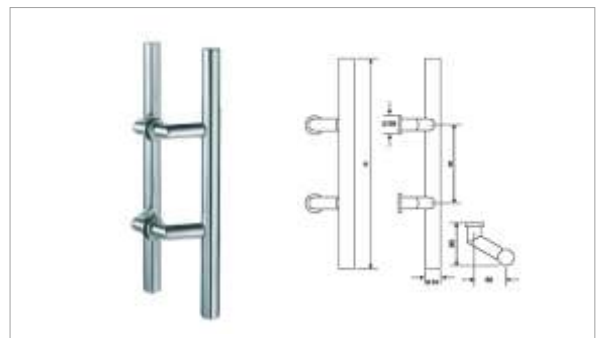

PH207

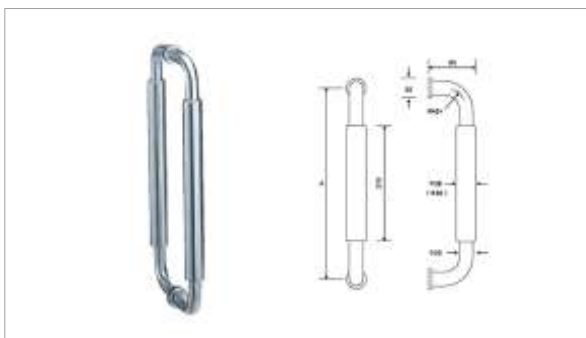

PH208

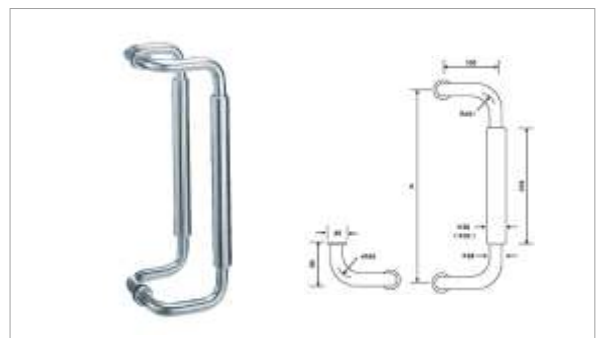

► This page product size can be customized.

PH209



PH210

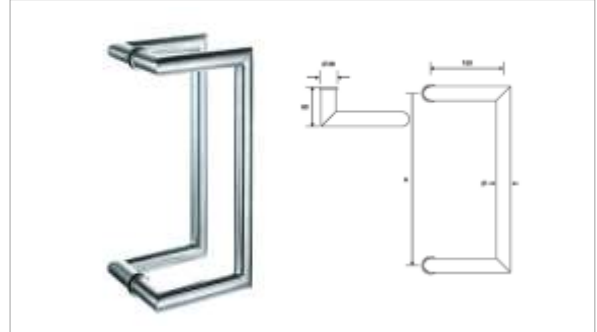

PH211

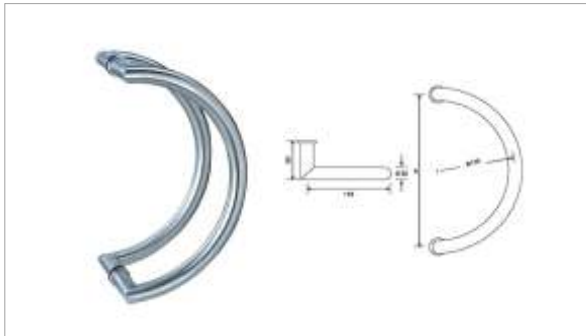

PH212

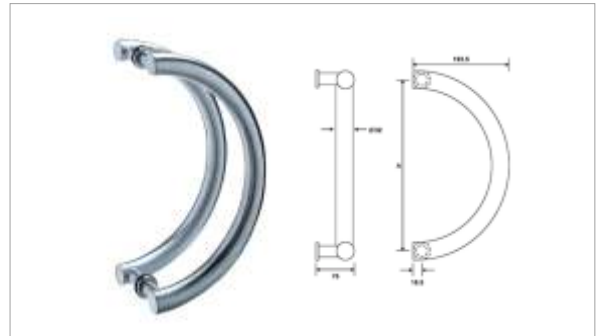

PH213

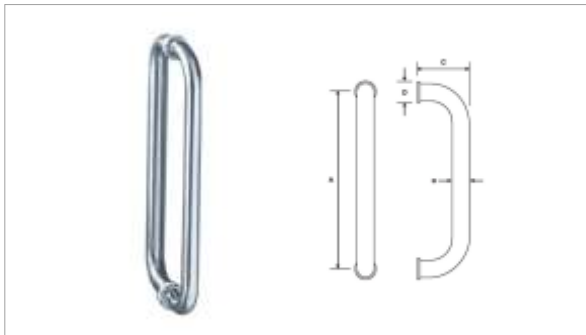

PH214



PH215

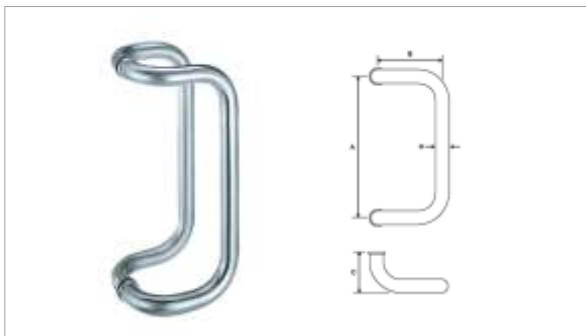

PH216

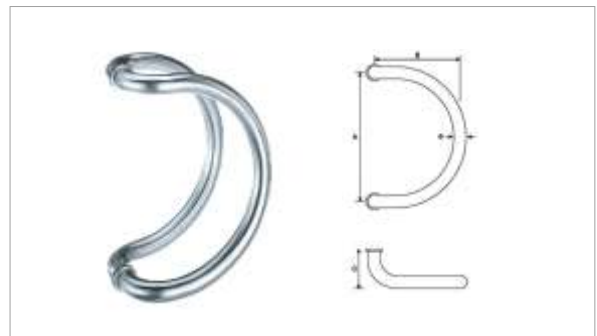

► This page product size can be customized.

PH217

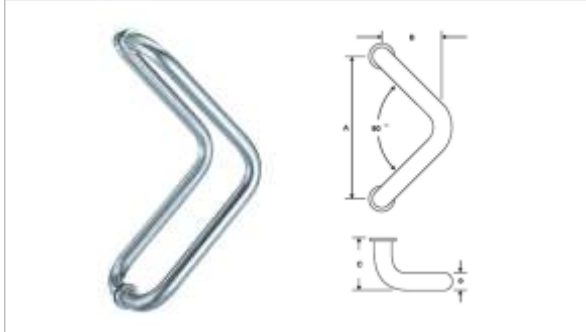

PH218



PH219

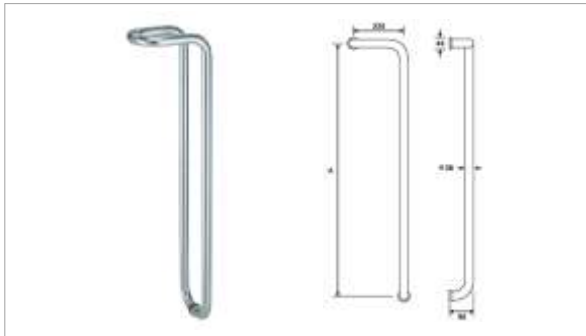

PH220



PH221

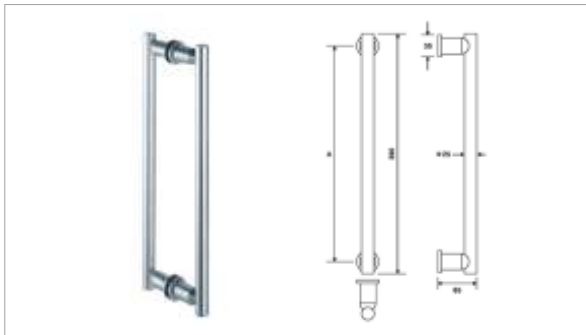

PH222

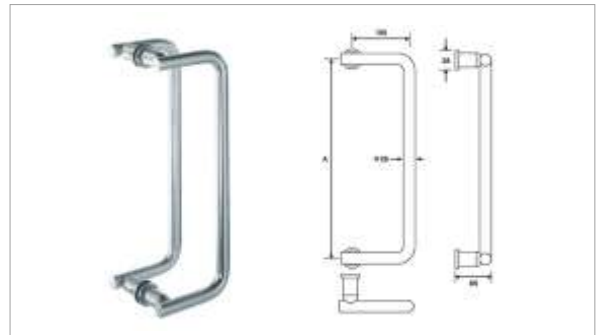

PH223

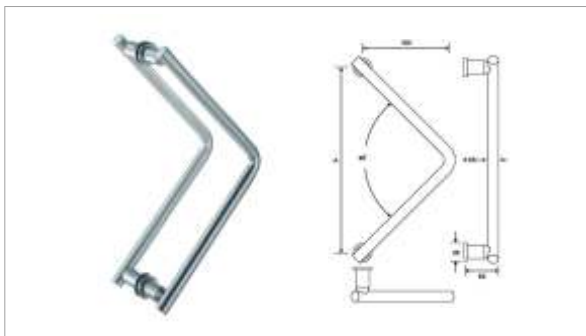

PH224

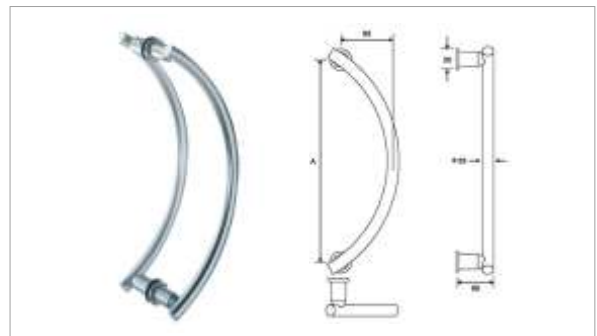

► This page product size can be customized.

PH225

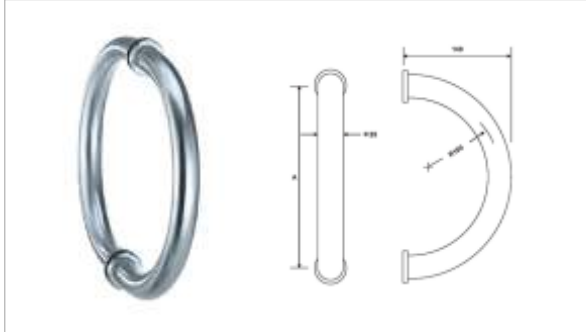

PH226

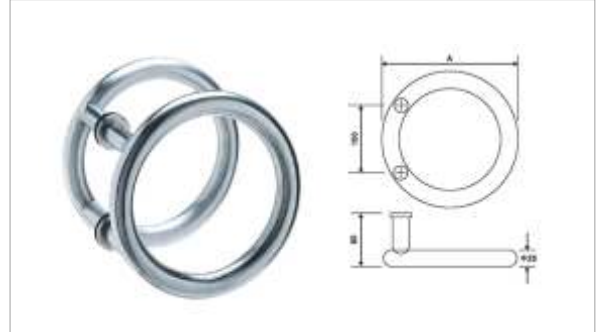

PH227

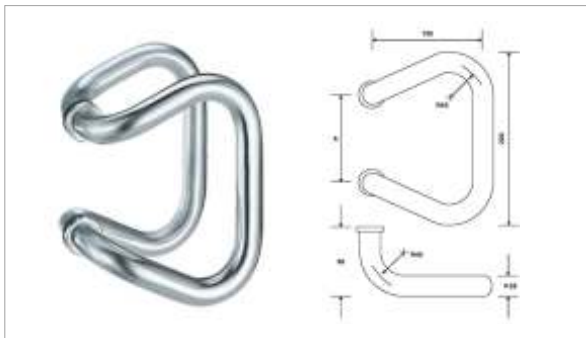

PH228

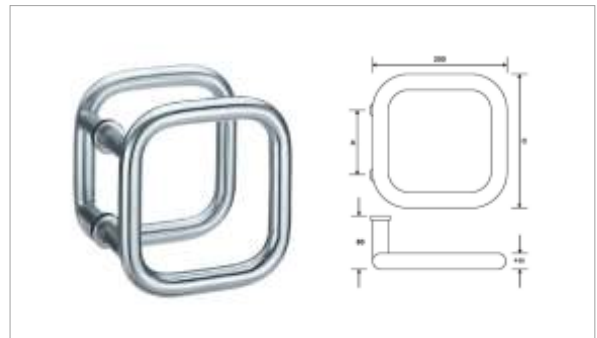

PH229

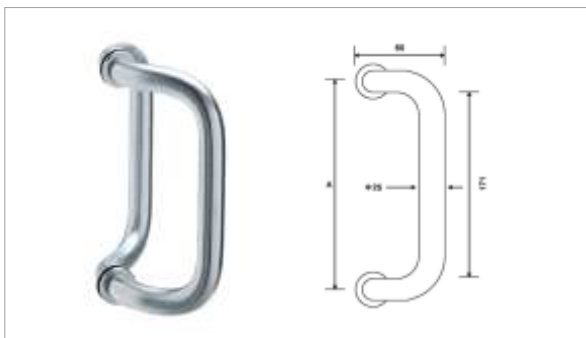

PH230



PH231

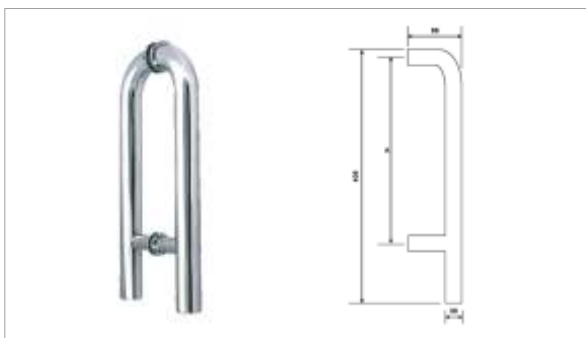

PH232

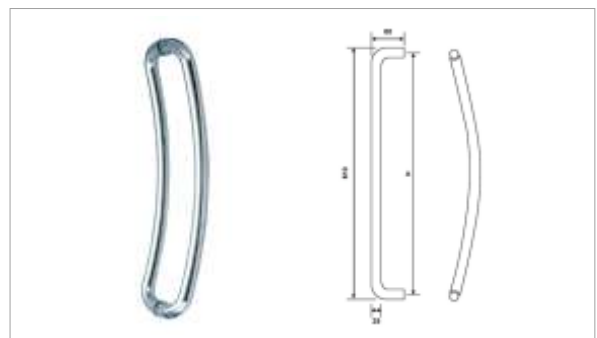

➤ This page product size can be customized.

PH233

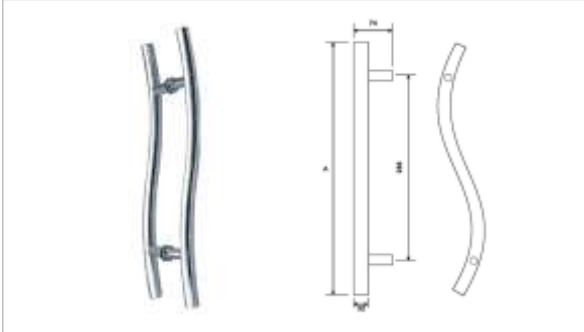

PH234



PH235

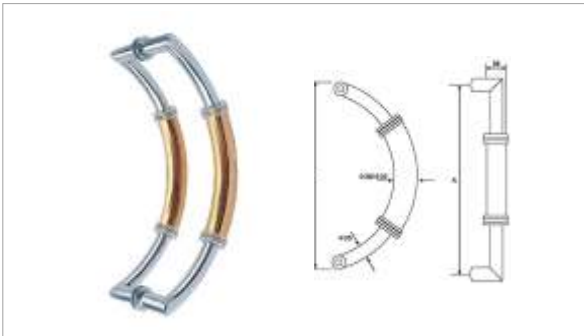

PH236

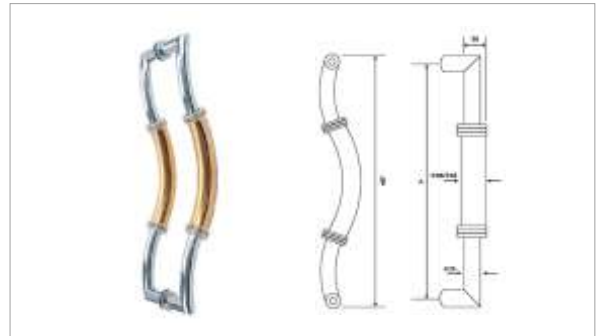

PH237

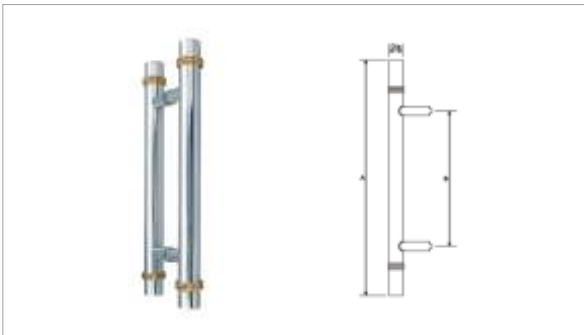

PH238

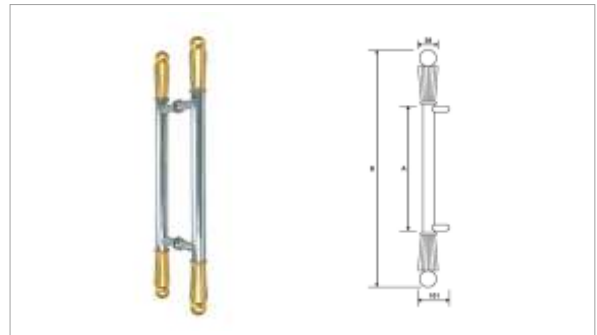

PH239

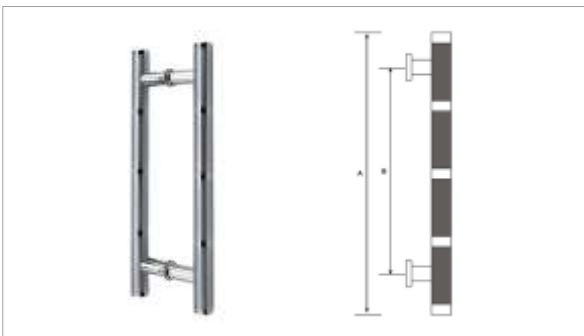

PH240

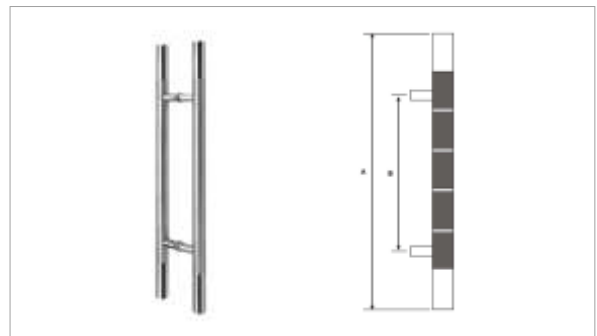

► This page product size can be customized.

PH241

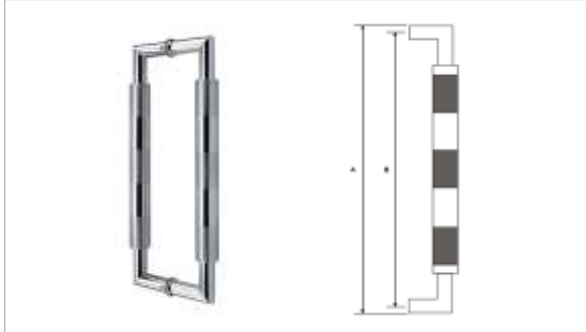

PH242

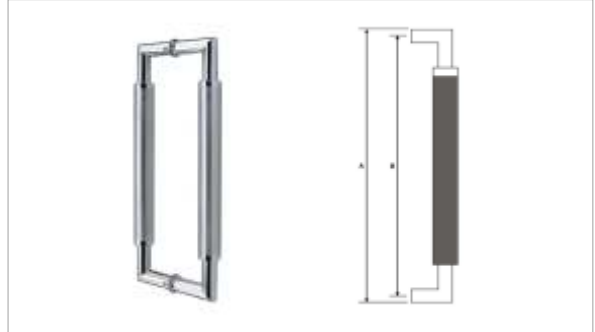

PH243



PH244

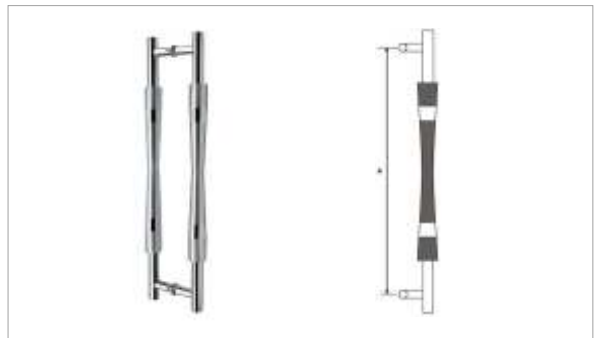

PH245

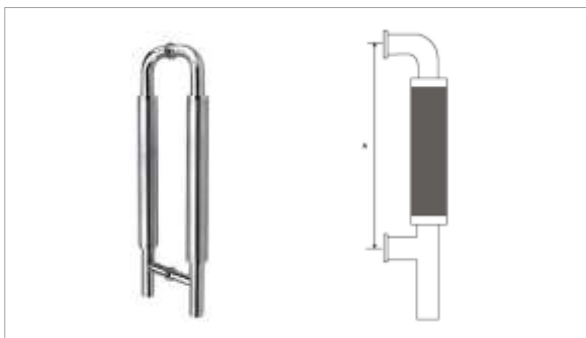

PH246

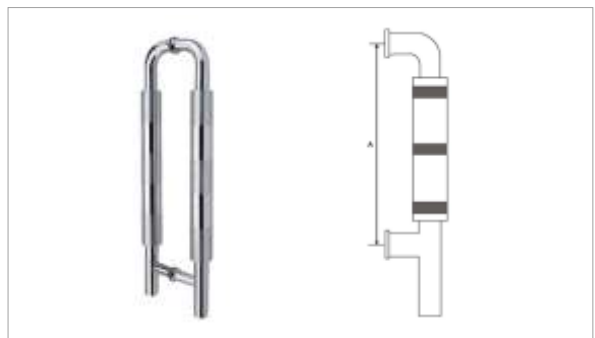

PH247

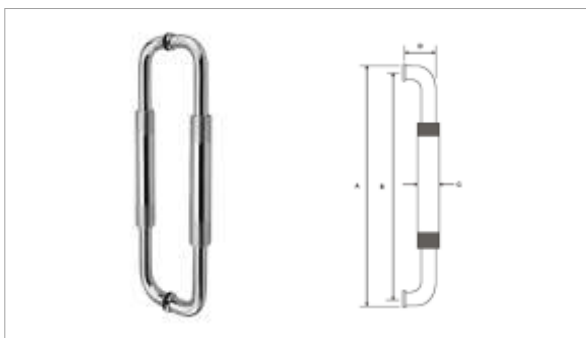

PH248

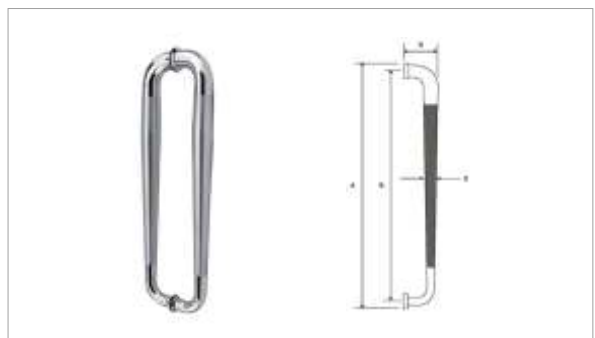

➤ This page product size can be customized.

PH249

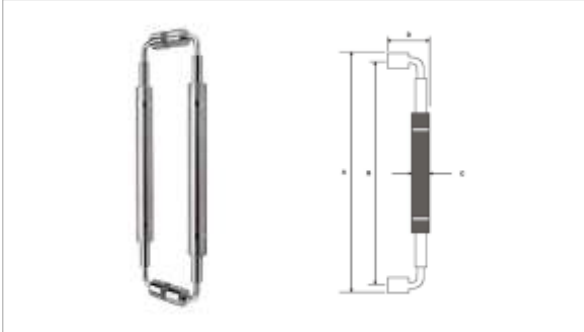

PH250

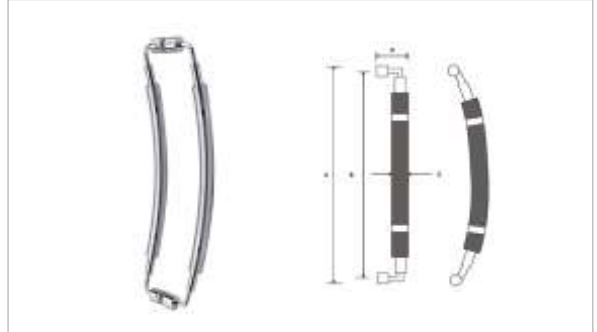

PH251

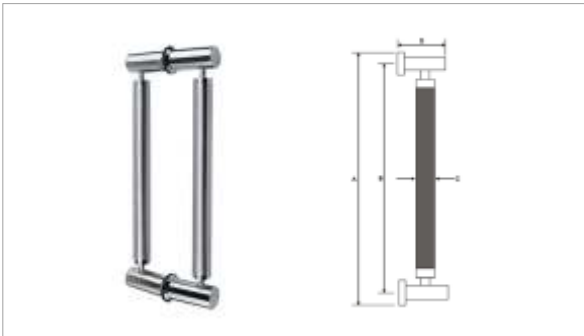

PH252

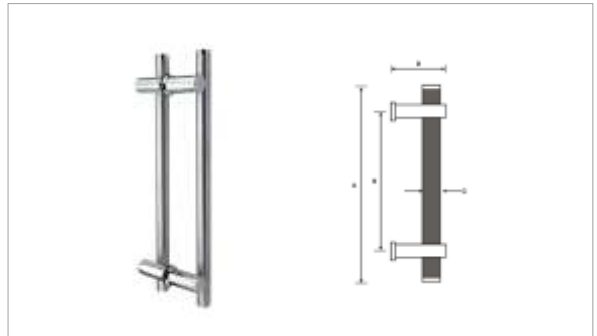

PH253

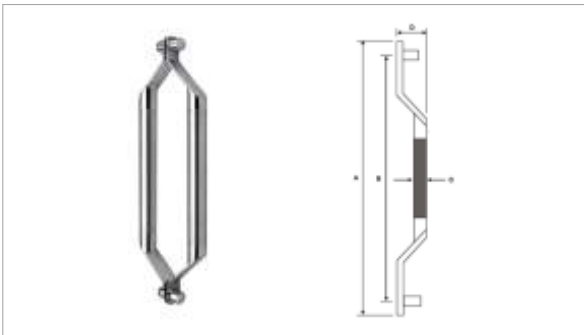

PH254

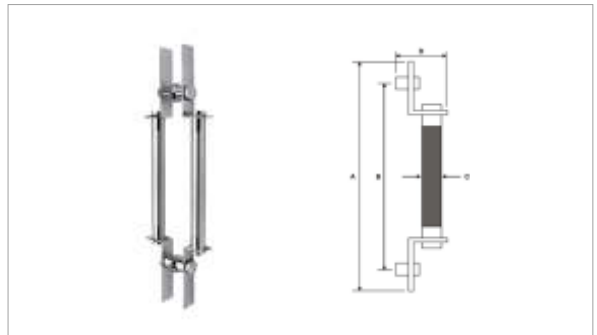

PH255

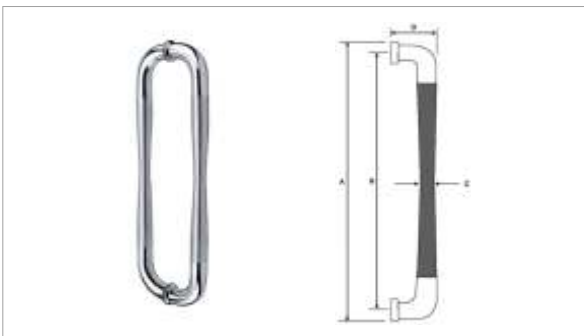

PH256



► This page product size can be customized.

PH257



PH258

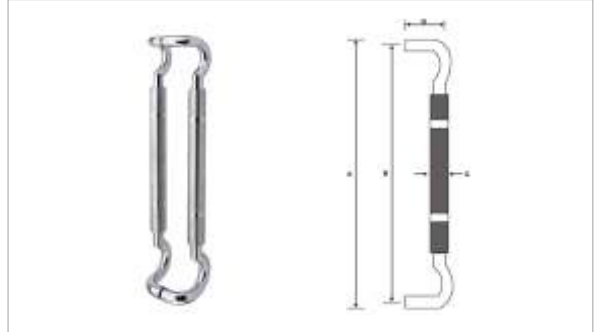

PH259



PH260



PH261

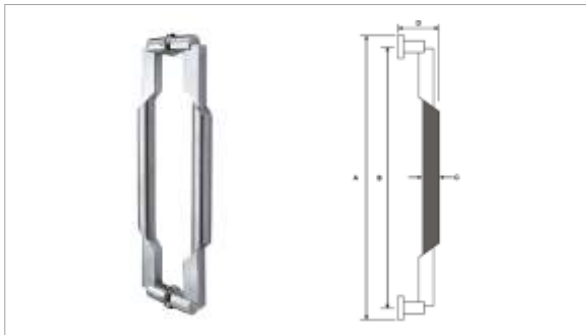

PH262



PH263

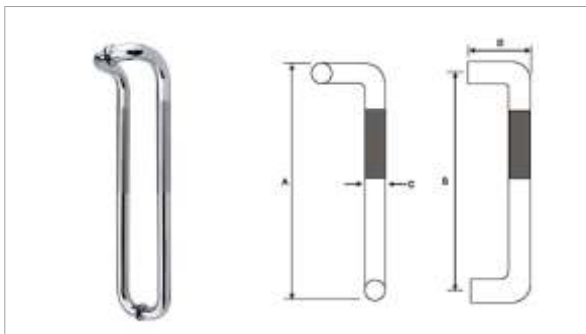

PH264



➤ This page product size can be customized.

PH265

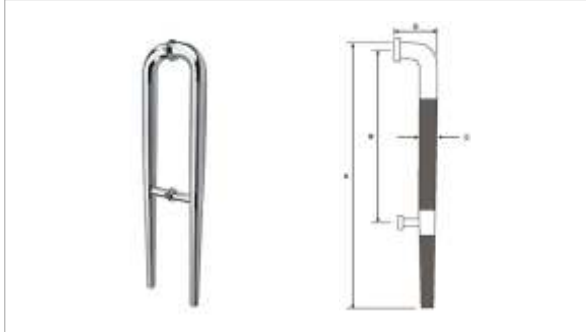

PH266



PH267

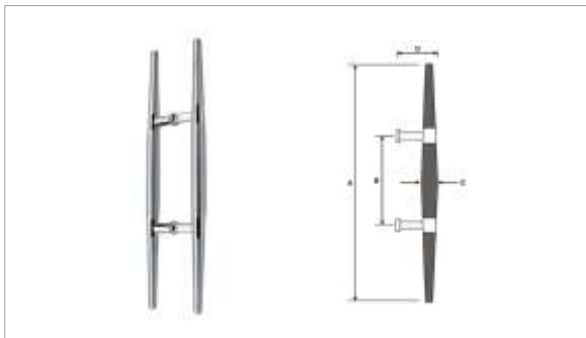

PH268

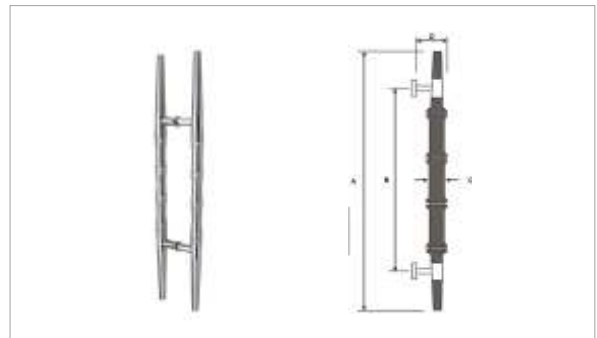

PH269

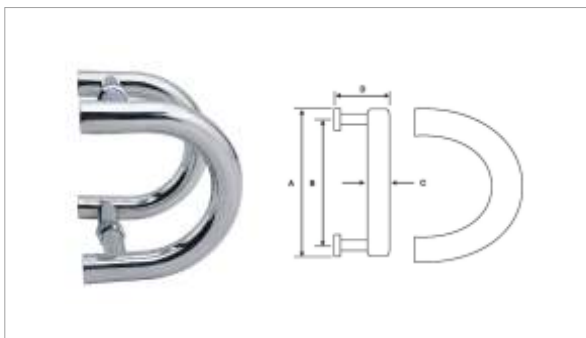

PH270

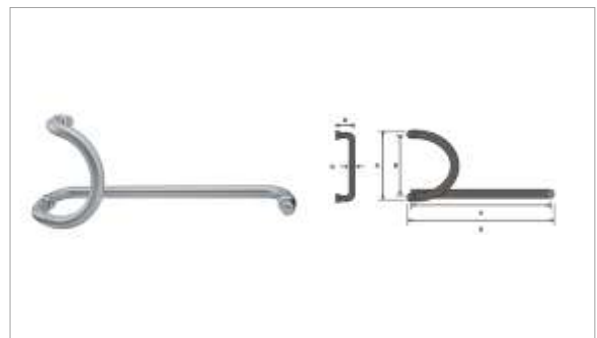

PH281

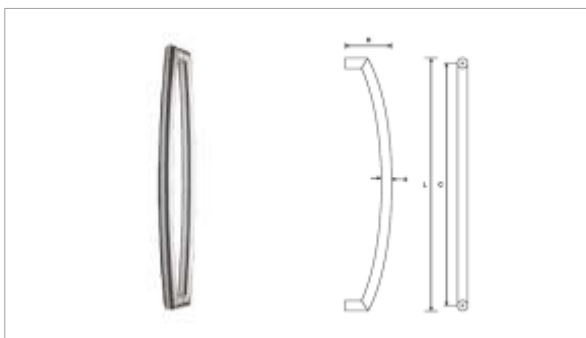

PH282

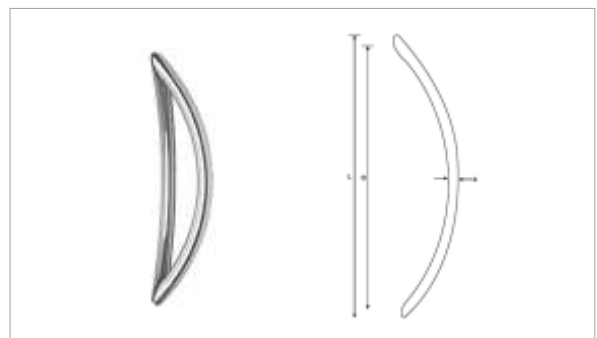

➤ This page product size can be customized.

PH283

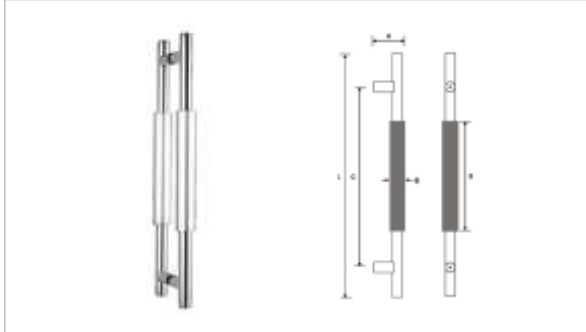

PH284



PH285

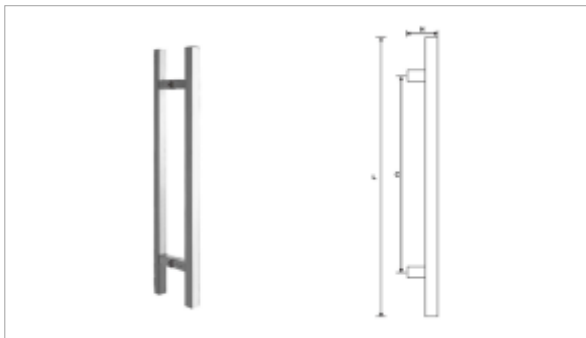

PH286

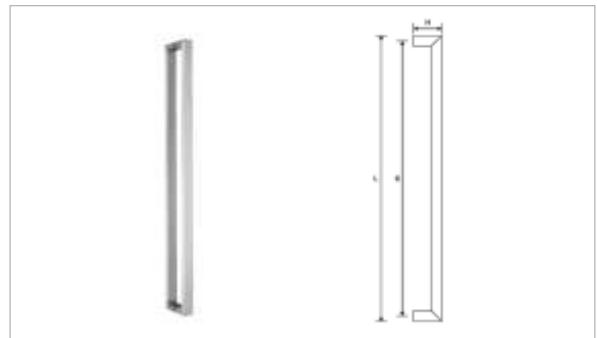

PH287A

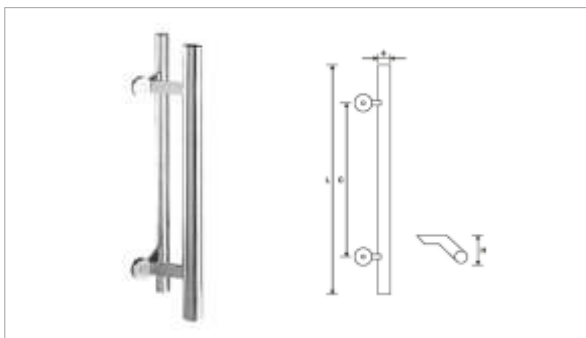

PH287B

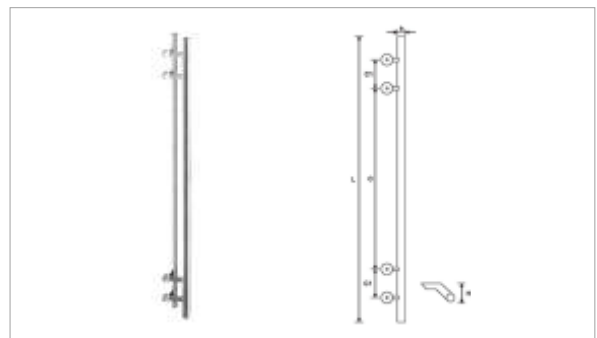

PH288A

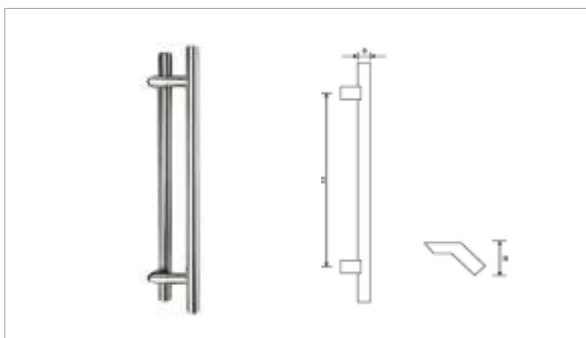

PH288B

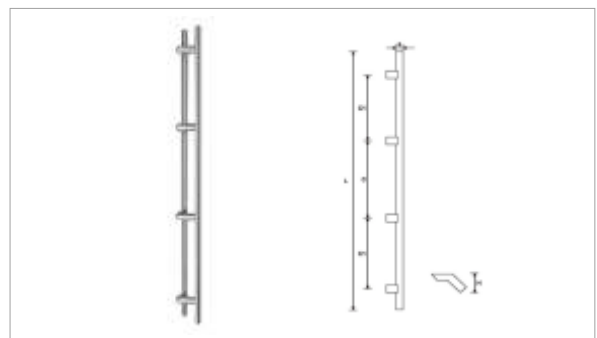

➤ This page product size can be customized.

PH289A

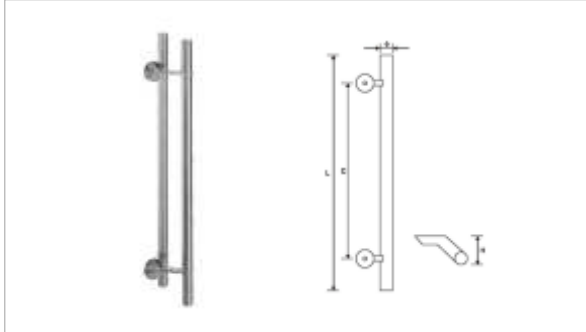

PH289B

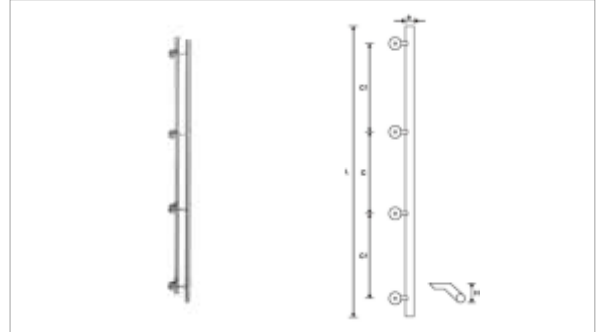

PH290A

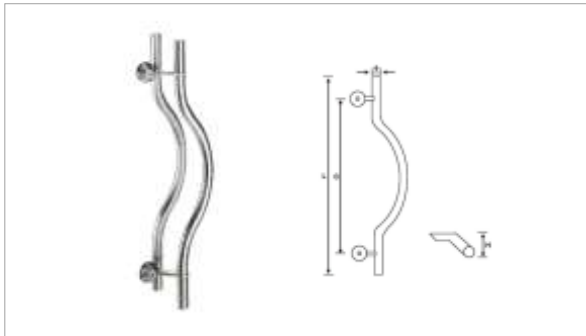

PH290B

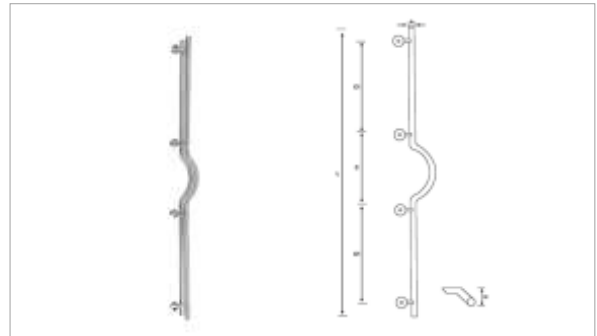

PH310

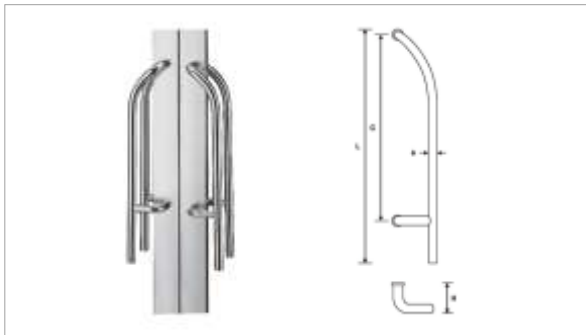

PH311

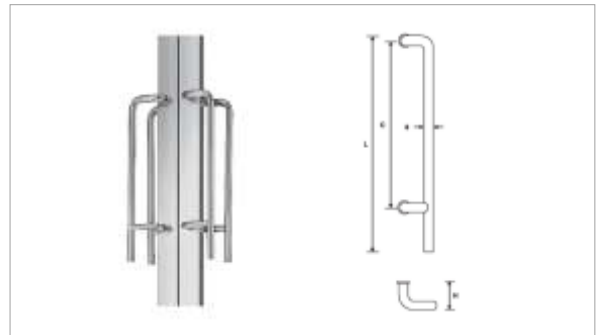

PH312

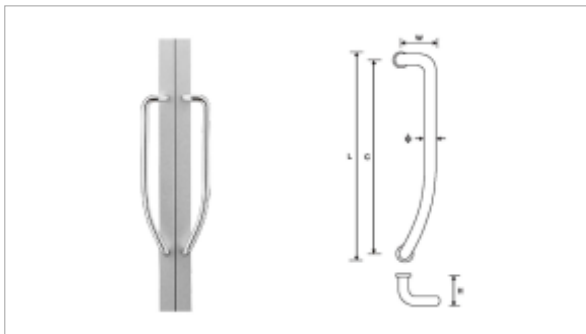

PH313

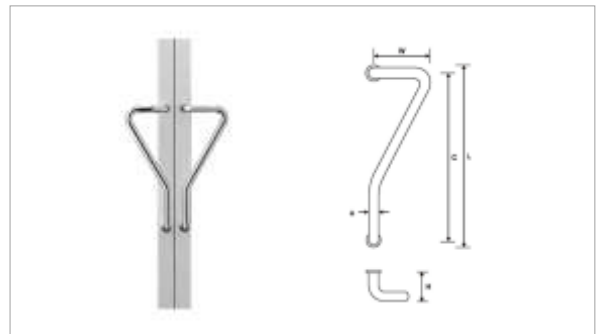

► This page product size can be customized.

PH314

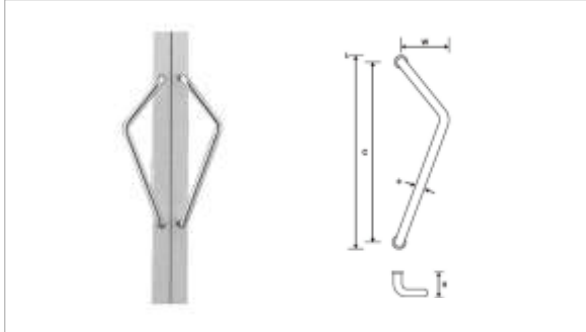

PH315

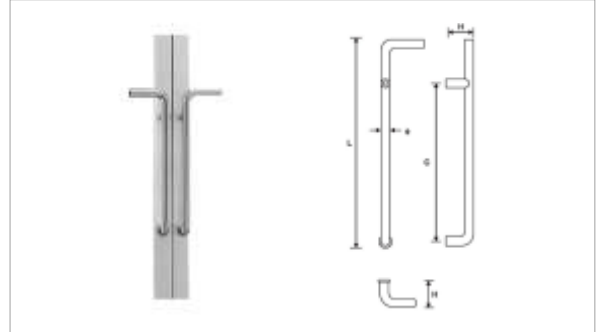

PH316

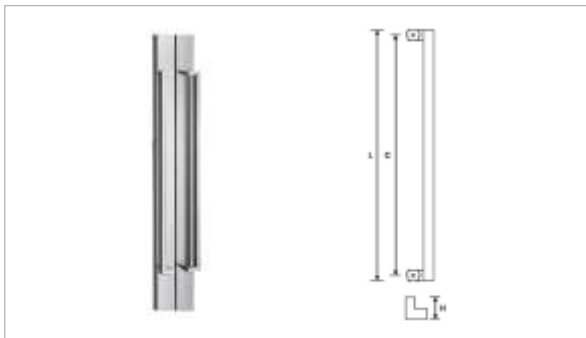

PH317

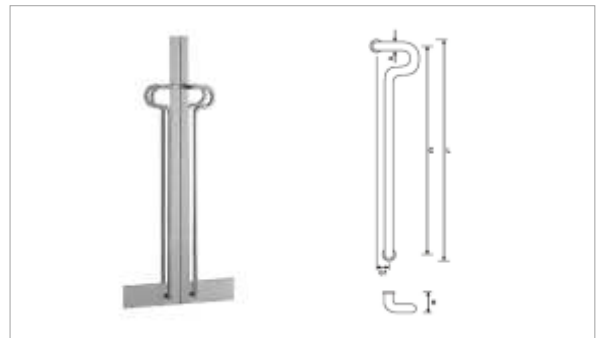

PH318

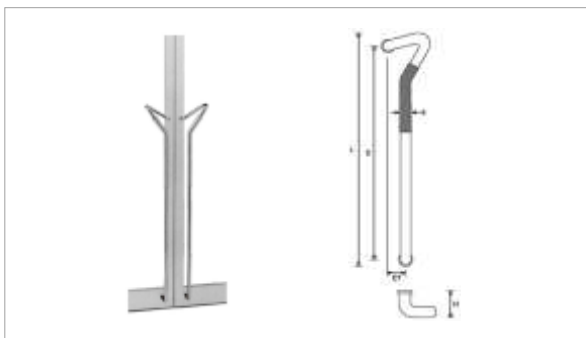

PH319

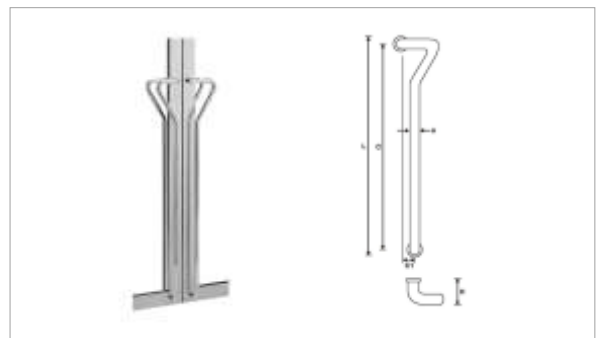

PH320

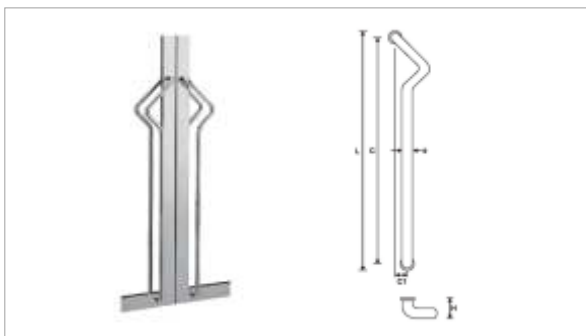

PH321

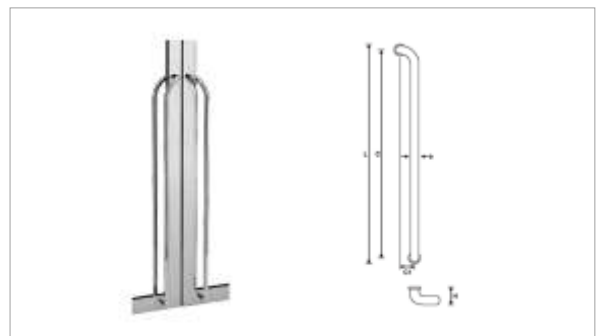

► This page product size can be customized.

PH322



PH301-a



PH301-b



PH302-a



PH302-b



PH302-c



➤ This page product size can be customized.

PH300-1

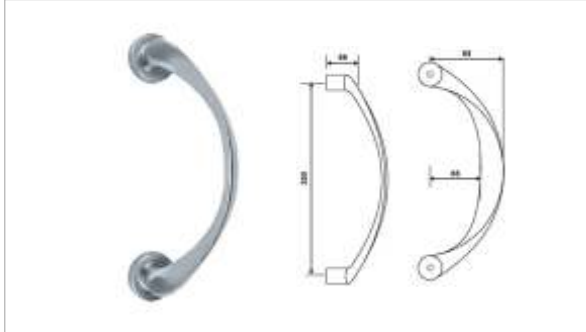

PH300-1-a

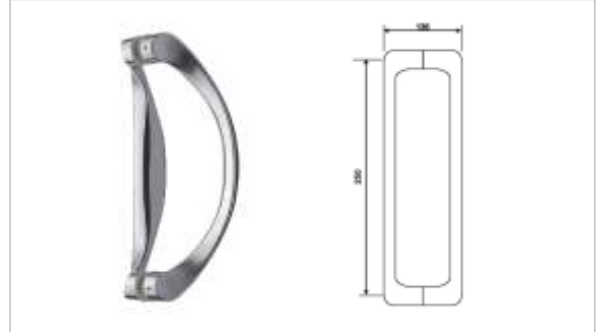

PH300-2

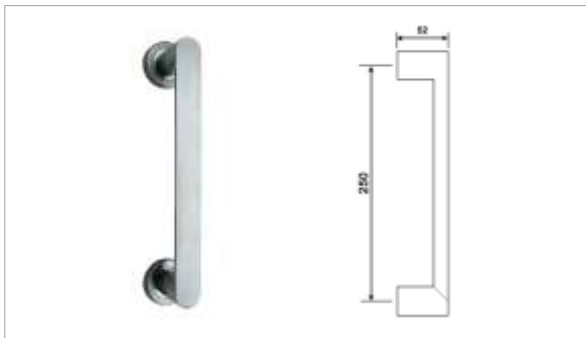

PH300-2-a

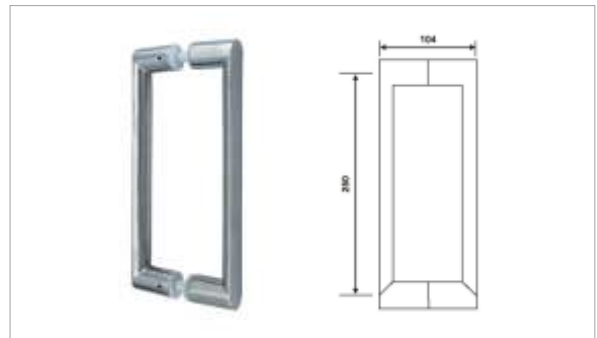

PH300-3

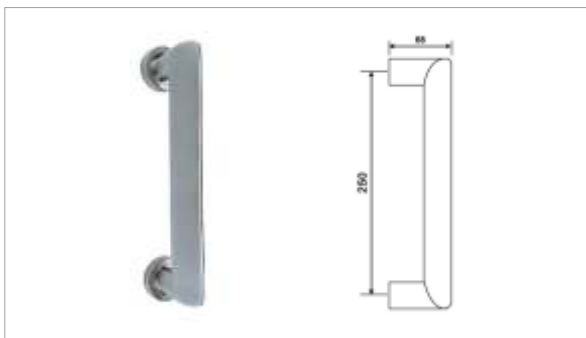

PH300-3-a

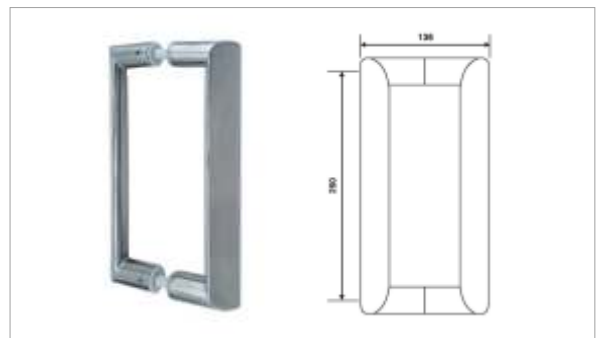

PH300-4



PH300-4-a

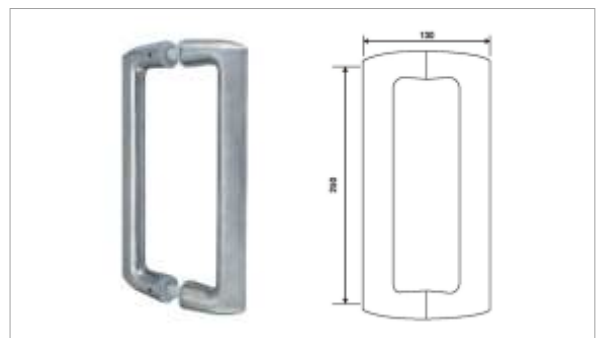

➤ This page product size can be customized.

PH300-5

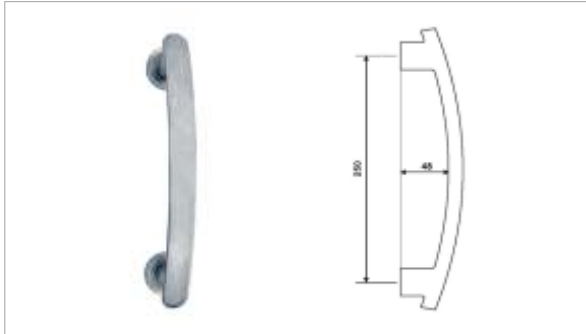

PH300-5-a



PH300-6

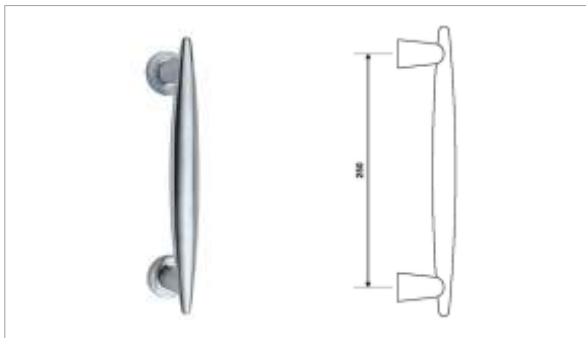

PH300-6-a

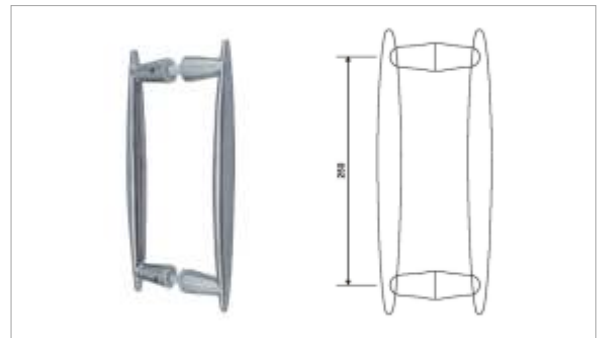

PH300-7



PH300-7-a

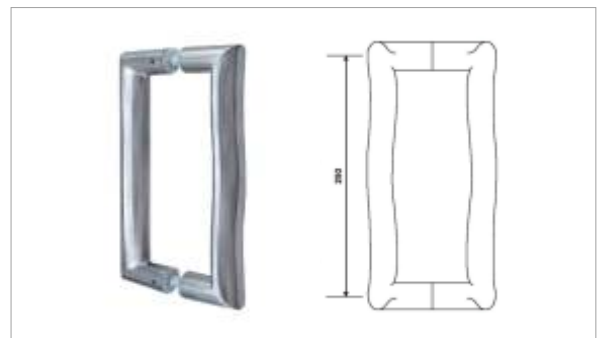

PH300-8

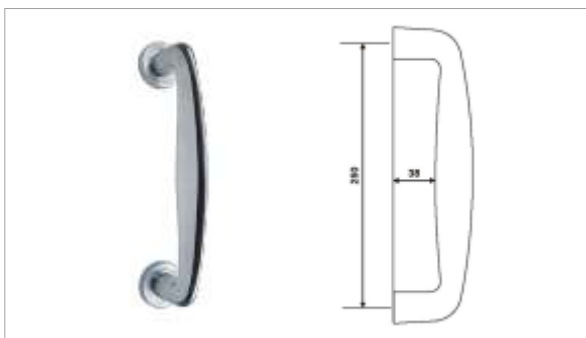

PH300-8-a



➤ This page product size can be customized.

PH300-9



PH300-9-a

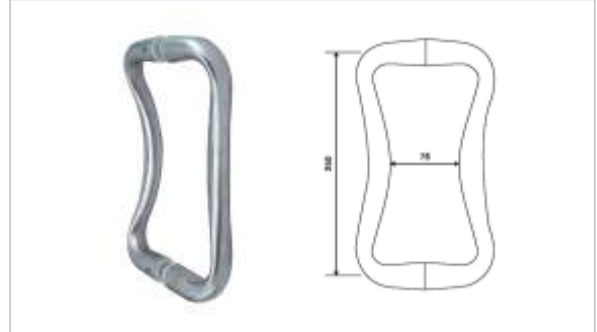

PH300-10



PH300-10-a

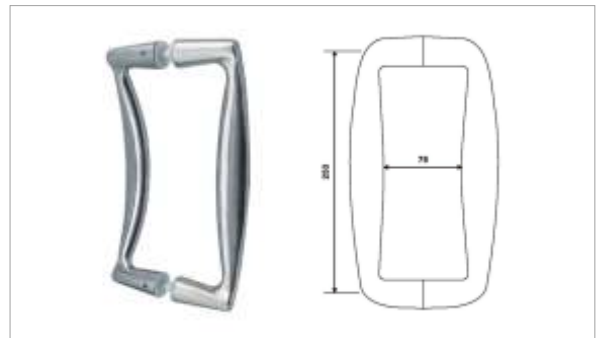

PH300-11



PH300-11-a



PH300-12



PH300-12-a

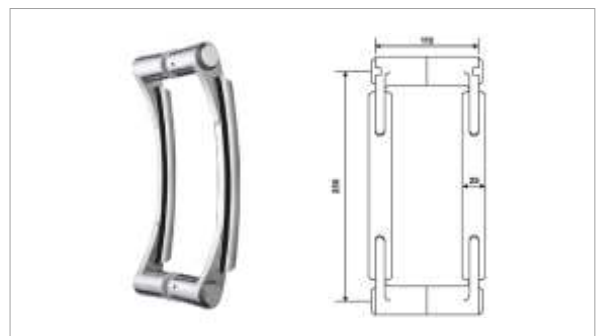

➤ This page product size can be customized.

PH300-13

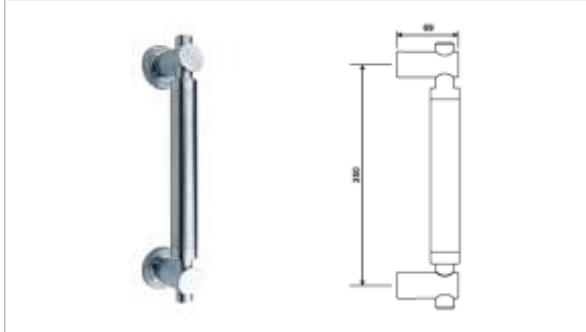

PH300-13-a

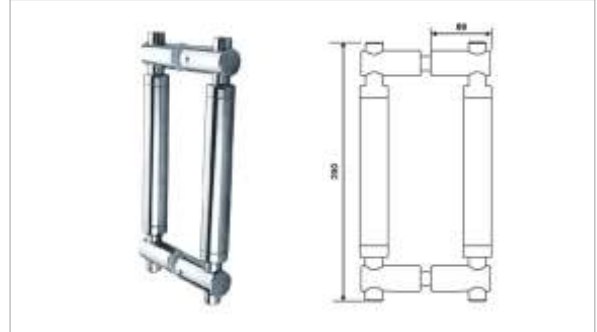

PH300-14



PH300-14-a

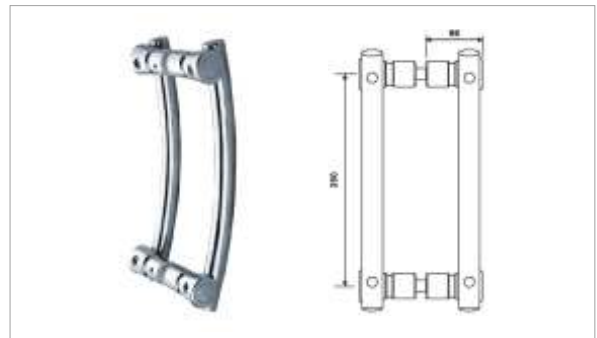

PH300-15

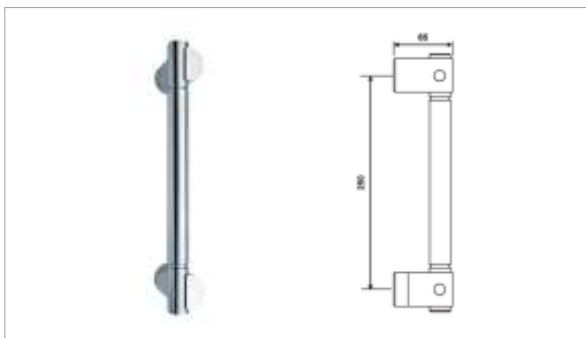

PH300-15-a

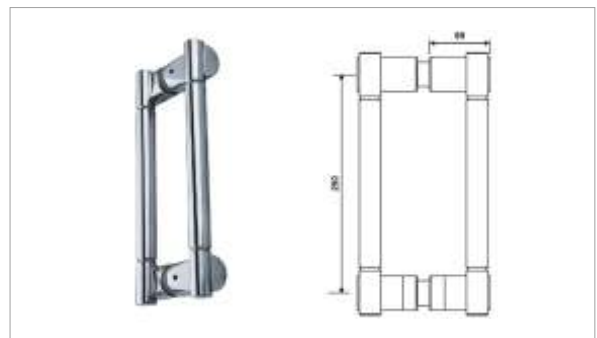

PH300-16



PH300-16-a

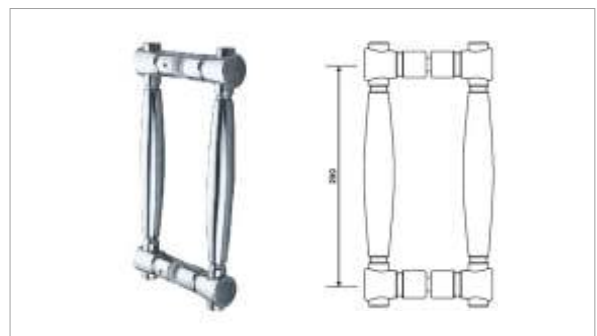

➤ This page product size can be customized.



Door Closer

- 5-1: Door Closer



DOOR CLOSERS



STANDARDS

CLASSIFICATIONS

Door closers are mainly used in commercial and public buildings, but may also be used around the home where circumstances make their use desirable. They have a variety of uses and applications, one of the main ones being to keep a door closed to limit the spread of fire and draught through-out a building. We have many different type of door closer available ranging from the simplest gate spring up to the more industrial floor springs.

The power of a door closer should relate to the width and weight of the door onto which it is to be fitted. The chart taken from the DIN EN 1154 provides a guide to selecting the correct and appropriate product.

POWER SIZES

Door closer Power size	Recommended Max door width(mm)	Max Test door Mass KG
1	<750	20
2	850	40
3	950	60
4	1100	80
5	1250	100
6	1400	120
7	1600	160

If a door closer is being fitted to a fire door, then it is usually recommended that a minimum of a size 3 in fitted. Air pressure on the door from wind is also a consideration which could lead to a higher size number than the actual door weight being needed. Restrictions in the design of certain buildings may lead to arrangements where special brackets are needed to mount the door closer.

The use of these brackets(fig. 61 or fig. 66 applications) can often weaken the strength of a closer and require that a size higher than that needed for the weight of the door is necessary. Some types of door closers can vary their strength number by altering the position of the closer on the door by means of moving it along a bracket. This is convenient where the size required is uncertain and facilitates a greater range of adjustment at the time of fitting. Typically these closers can be designated 2-4 size or even 2-6 size in certain circumstances.

BACK CHECK

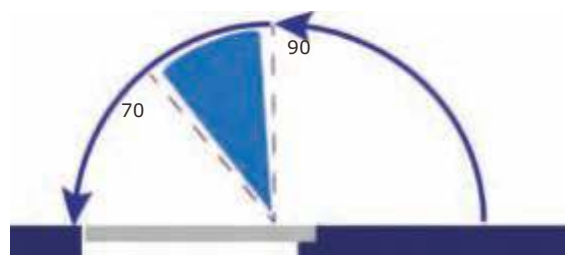

Door closers can be supplied with an optional "back check" action included between app. 70° and 90° . This back check action provides resistance within the door closer to prevent the door leaf from being thrown open. This prevents damage to the door, door frame and door handles caused by people kicking or throwing the door open and also by the door being violently blown open by the wind. The angle and resistance of the back check can be varied according to your requirements. When using a door closer with a back check facility it is worth remembering that this facility puts extra strain on the door hinges - remember to allow for this when choosing you hinges!



DELAYED ACTION

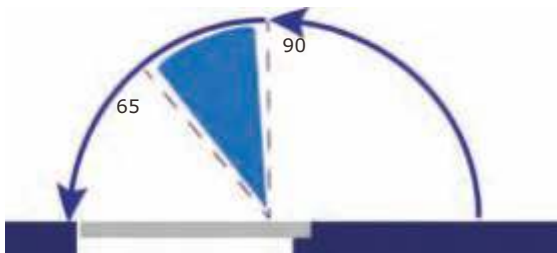

For slow moving traffic such as strollers and wheel chairs it is best choosing a door closer which has a “delayed action”. This allows the door to remain open for a preset period of time before closing at an adjustable speed. Such a system will allow people in wheelchairs or the elderly to get through the door before it starts to close.

LATCH ACTION

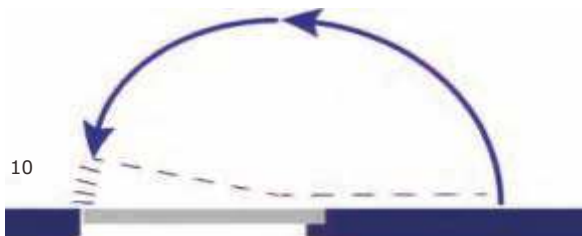

Latch action provides for the adjustment of the app. last 10° of the closing cycle. This allow the closer to be adjusted to overcome a latch or intumescent seal.

DIN EN 1154 - DOOR CLOSERS

Door closers need to be tested/certified according to DIN EN 1154 code system. The standard classifies door closers by

means of a 6 digit coding system. The digits relate to a particular feature of the product measured against the standards performance requirements.

Digit 1 - Category of use

Grade 3 is for doors closing from at least 105° and grade 4 is for doors closing from 180° .

Digit 2 - Durability

Grade 8 indicates that 500,000 test cycles are completed

Digit 3 - Test door mass/size

This identifies seven grades of power as indicated in the table provided on opposite side.

Digit 4 - Fire Behaviour

Grade 0 is not suitable for use on fire/smoke doors, Grade 1 is suitable for use on fire/smoke doors. This feature is assessed outside of EN 1154.

5th Digit - Safety

All door closers are required to satisfy the essential requirement of safety in use and then designated Grade 1.

6th Digit - Corrosion resistance

Five grades are identified
 Grade 0 = no defined resistance
 Grade 1 = mild resistance
 Grade 2 = moderate resistance
 Grade 3 = high resistance
 Grade 4 = very high resistance.

DC-982



DC-982A

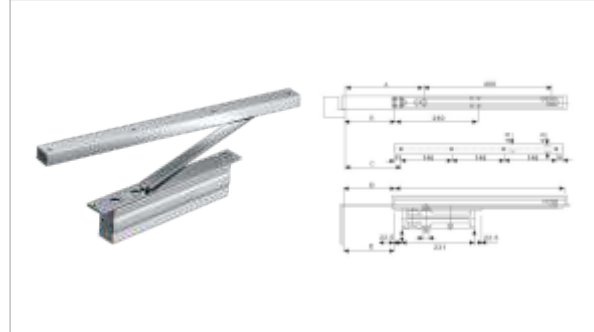

DC-202

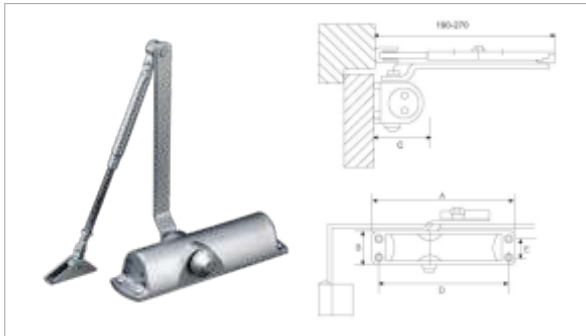

DC-203

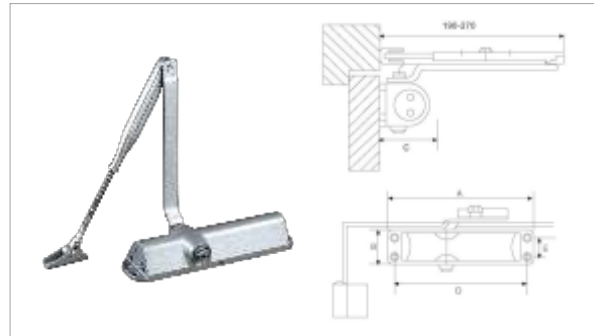

DC-051

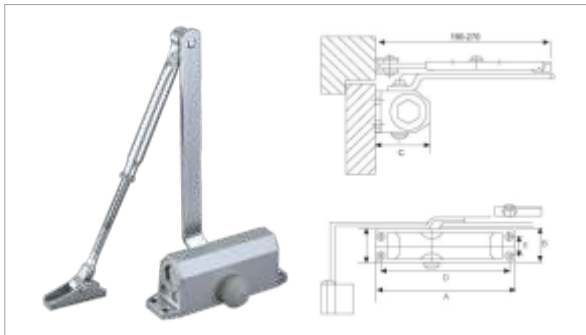

DC-071A

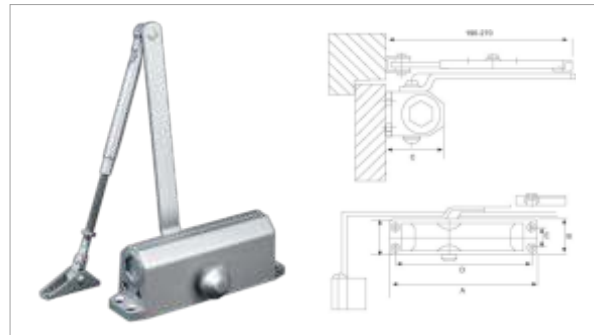

DC-082

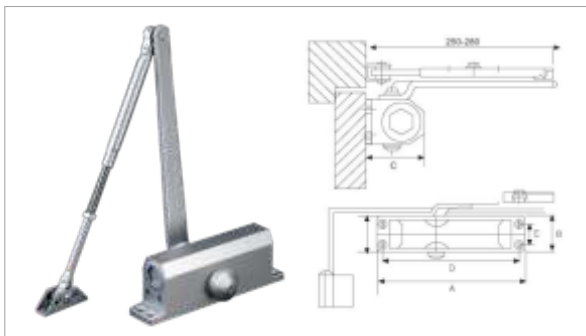

DC-061A

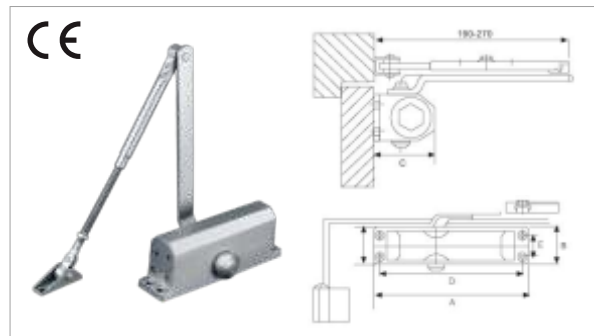

DC-073

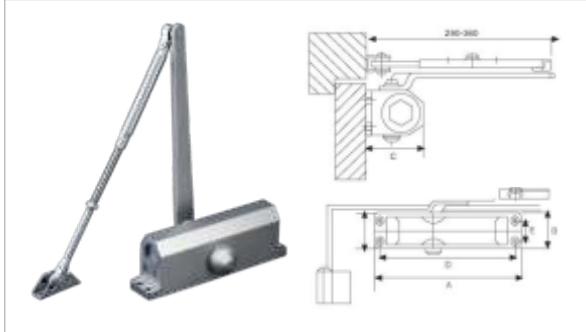

DC-2001

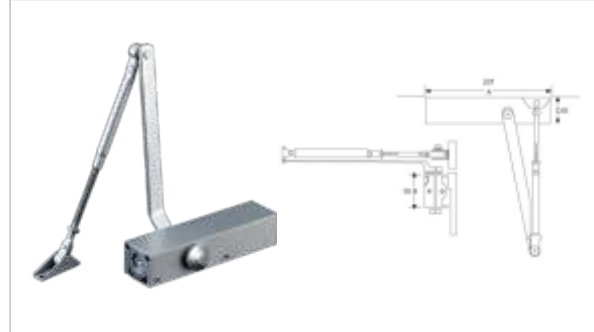

DC-3000

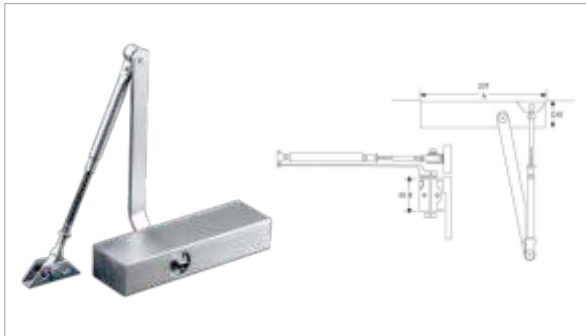

DC-2003

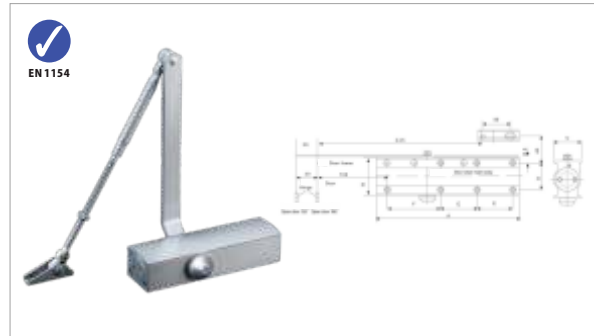

DC-4000

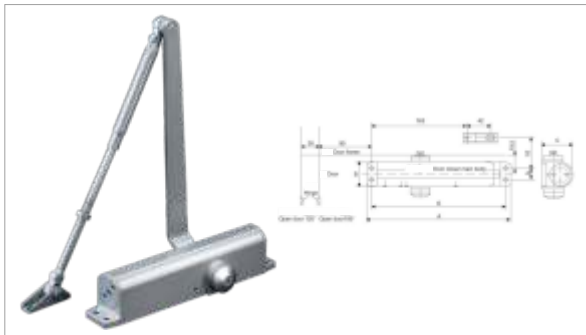



Accessory

- 6-1: Door Stopper
- 6-2: Door Holder
- 6-3: Door Guard
- 6-4: Door Bolt
- 6-5: Dust Proof Strike
- 6-6: Door Viewer
- 6-7: Ball Catch
- 6-8: Door Coordinator
- 6-9: Mirror Screw
- 6-10: Glass Holder
- 6-11: Door Bell
- 6-12: Number & Mail
- 6-13: Furniture Conceal Handle
- 6-14: Furniture Handle
- 6-15: Furniture Knob
- 6-16: Hook
- 6-17: Hang Wheel
- 6-18: Furniture Drawer
- 6-19: UL Panic Exit
- 6-20: Cup Handle
- 6-21: Sing Plate
- 6-22: Washroom Fitting
- 6-23: Washroom Cubicle
- 6-24: Handrail System



ACCESSORIES

PUCK

DH001SS

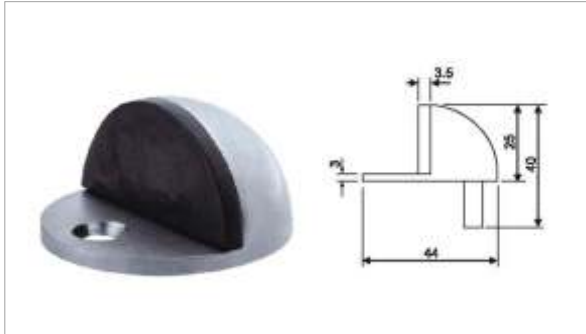

DH001SS-B

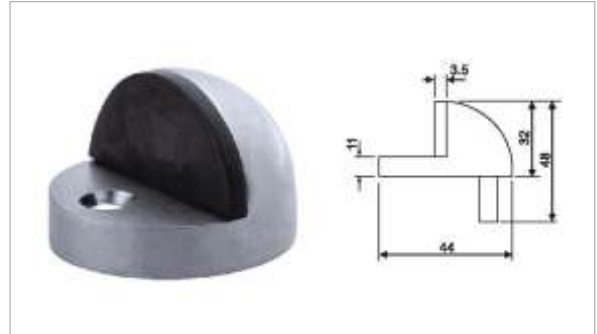

DH002ZA

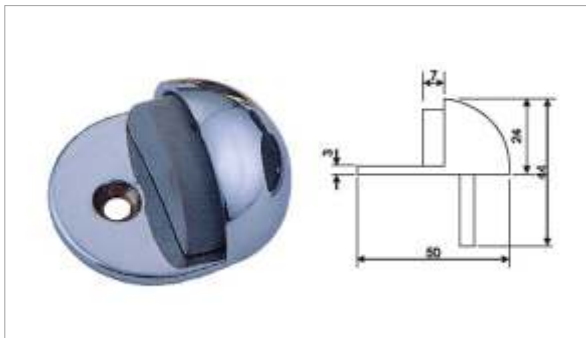

DH002ZA-B

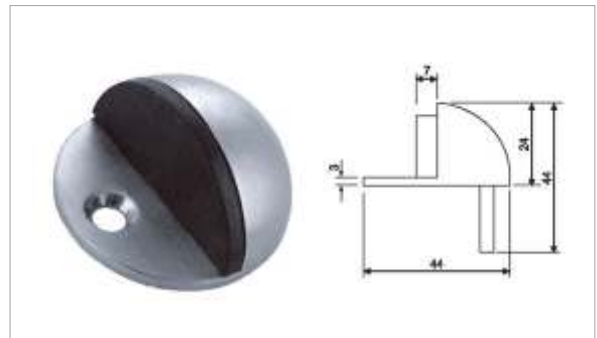

DH003BR

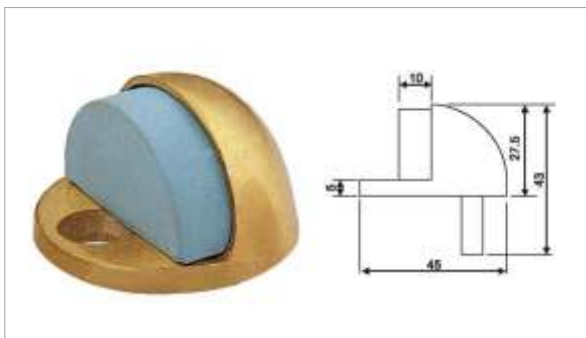

DH004BR

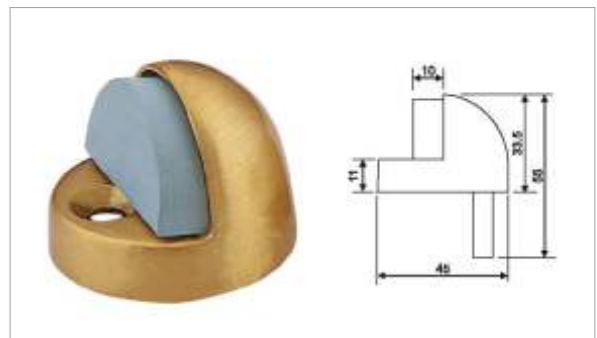

DH005SS

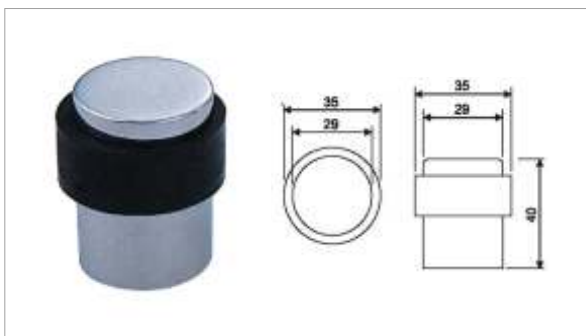

DH006SS

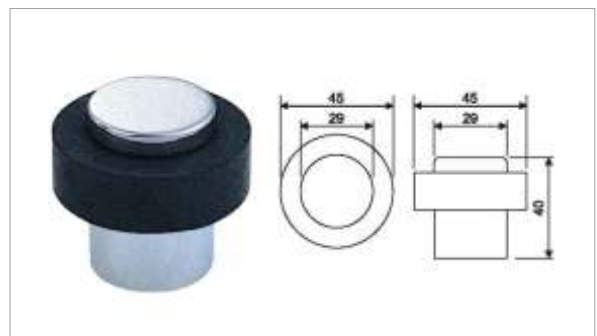

DH007SS



DH008SS-A



DH008SS-B

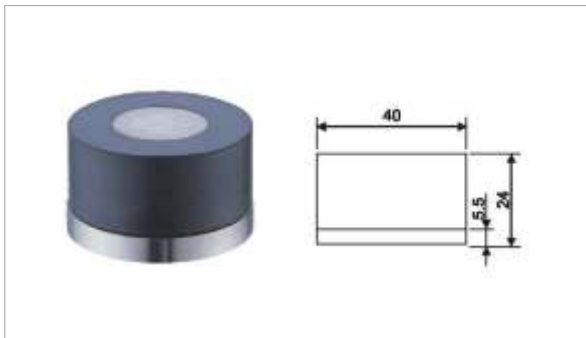

DH009BR



DH010ZA



DH011SS

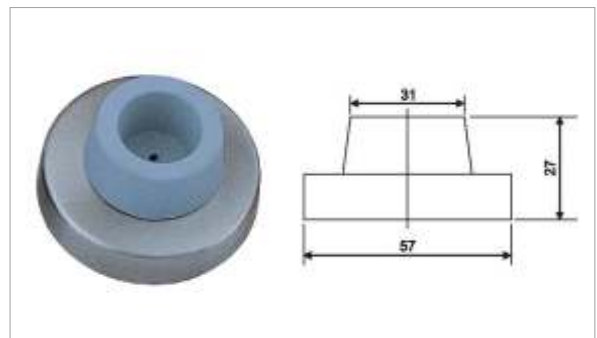

DH012BR



DH013BR

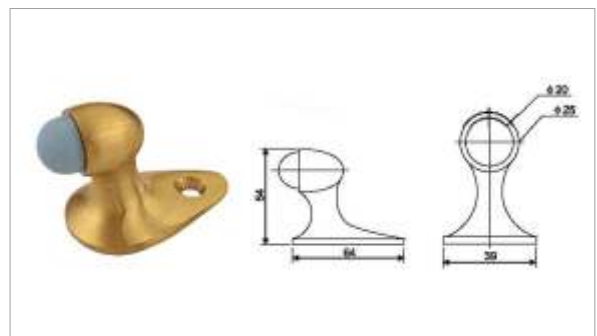

DH014BR



DH015BR



DH016BR



DH017BR



DH018BR

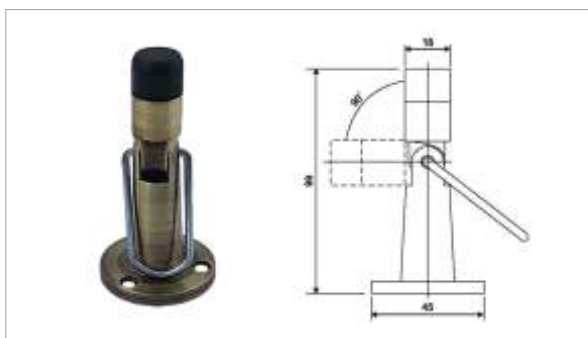

DH019BR



DH020BR



DH021SS

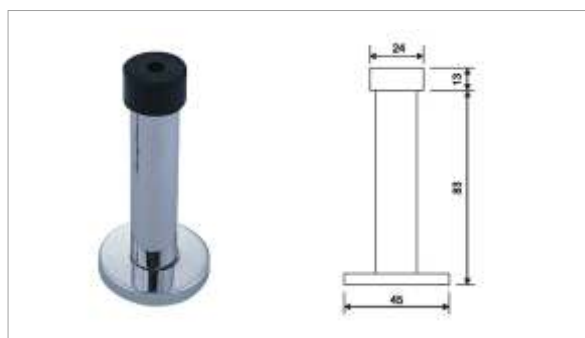

DH022SS

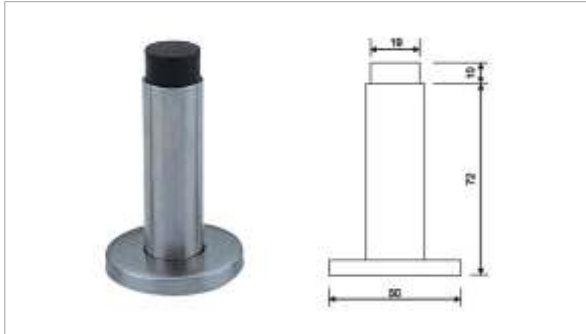

DH023SS



DH024SS

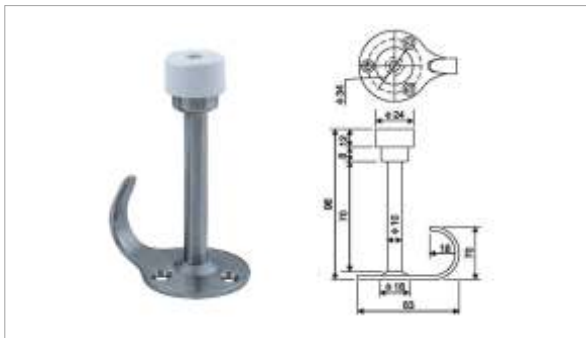

DH025SS/BR



DH026SS/BR



DH027SS/BR



DH028SS



DH033ZA

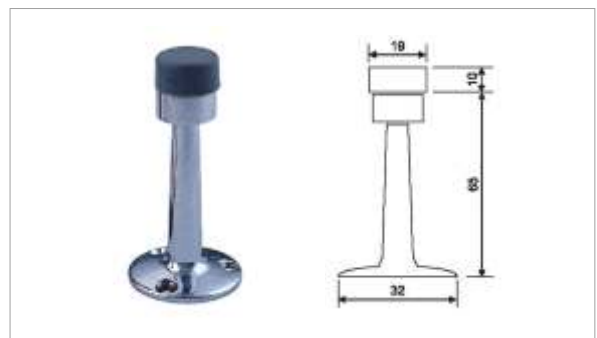

DH034ZA



DH035ZA



DH036SS



DH037SS

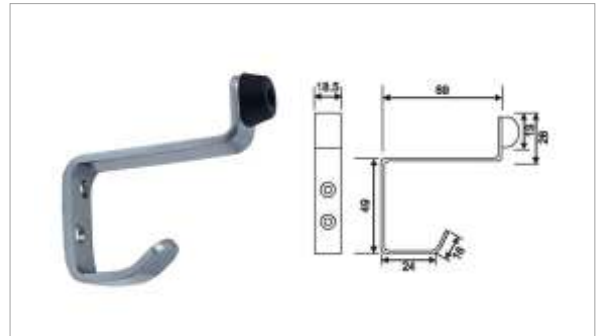

DH038SS

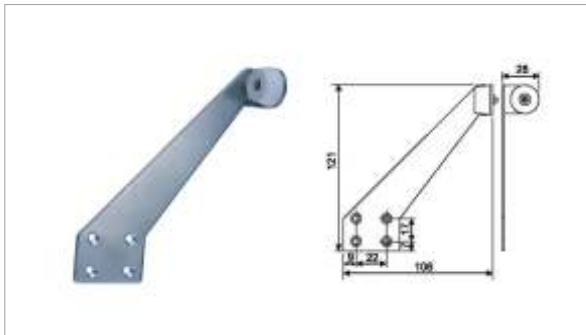

DH039SS-A

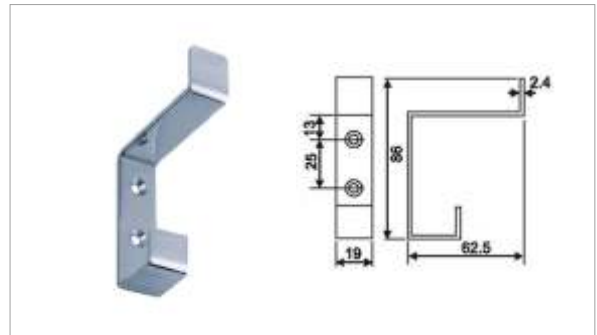

DH039SS-B

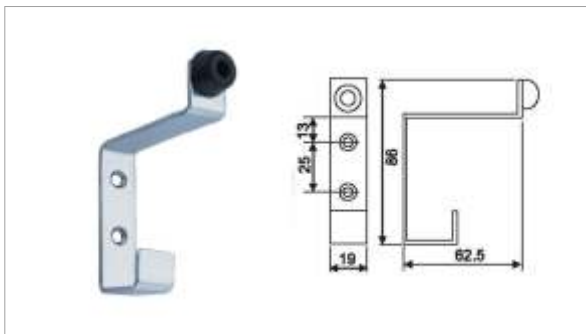

DH040SS

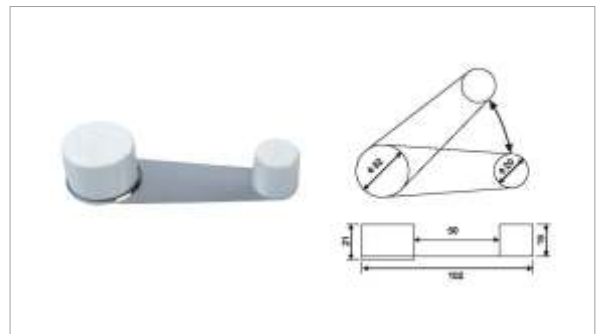

DH041SS

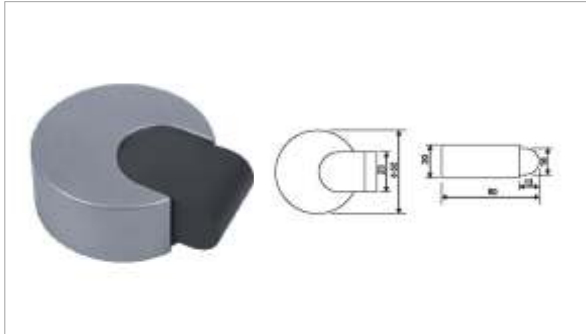

DH042SS

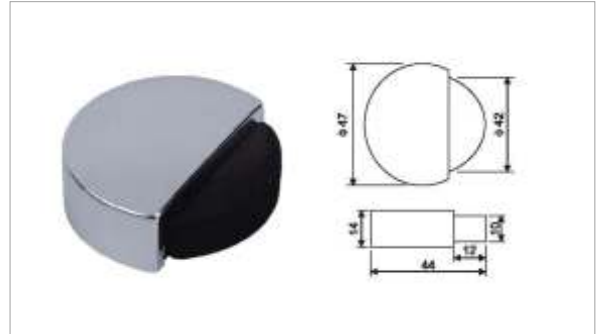

DH0800



DH057SS/BR



DH058SS/BR



DH059SS

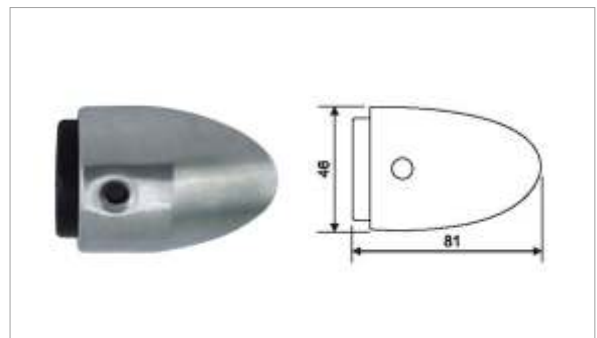

DH060SS/BR



DH061SS/BR



DH062SS/BR

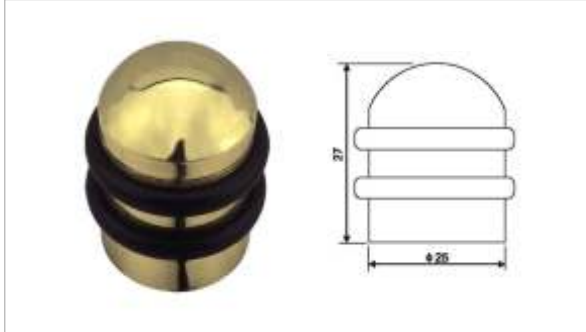

DH063SS/BR



DH064SS/BR



DH065BR



DH066BR



DH067BR



DH068SS/BR



DH069SS



DH070SS

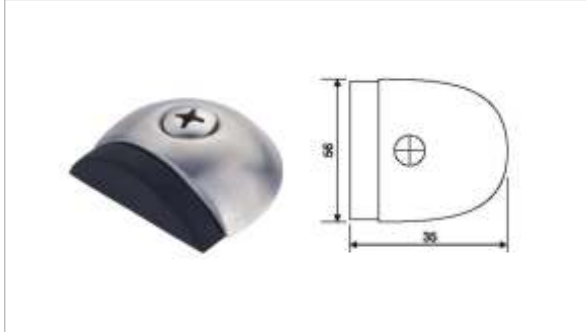

DH071SS



DH072AL

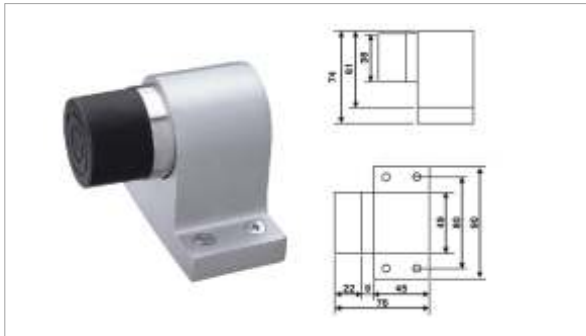

DH073SS



DH074SS



DH075SS



DH076SS/ZA

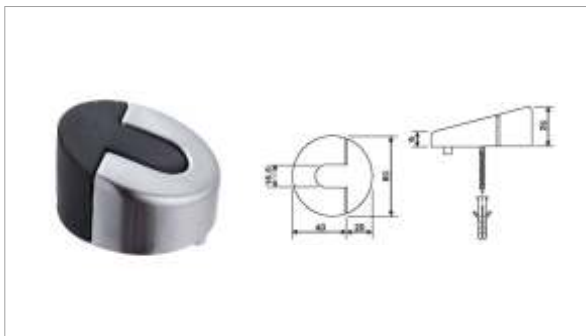

DH077SS

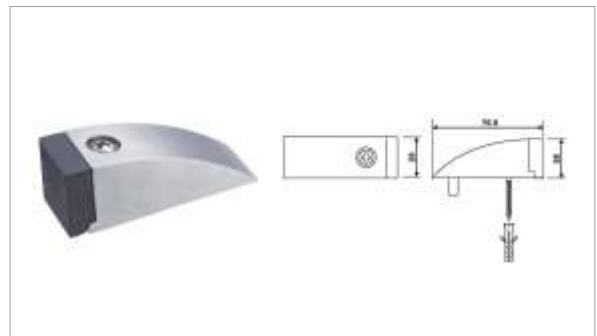

DH078SS/ZA



DH079SS



DH080SS/BR



DH081SS/BR



DH082BR



DH083BR



DH084SS

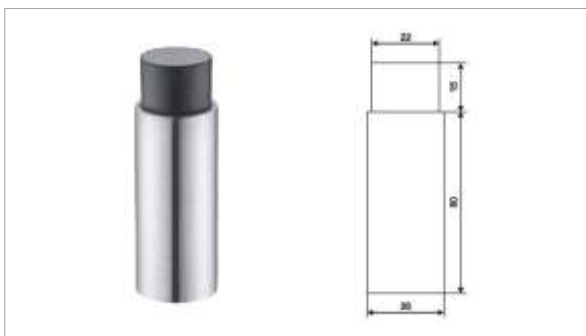

MDS-001ZA

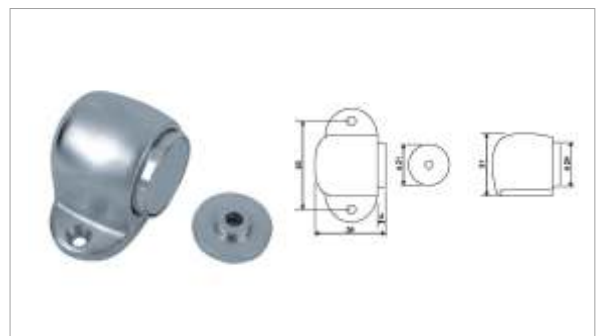

MDS-002BR

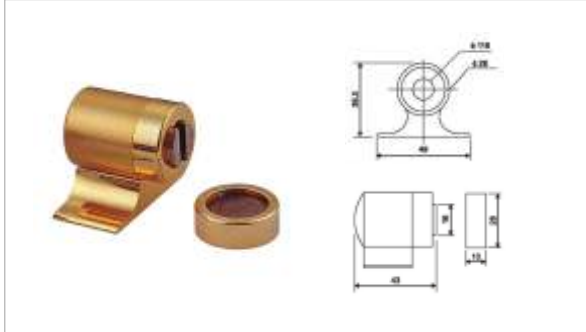

MDS-003ZA

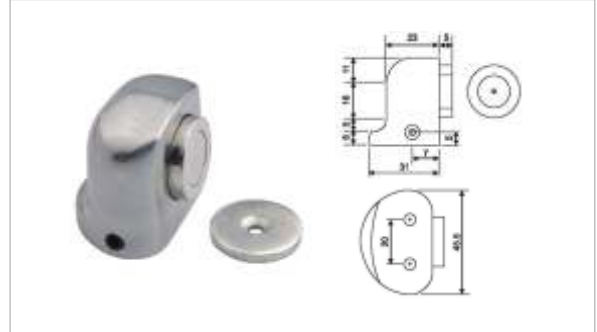

MDS-004BR/ZA



MDS-005BR/ZA



MDS-011BR/ZA



MDS-007BR/ZA



MDS-008BR/ZA

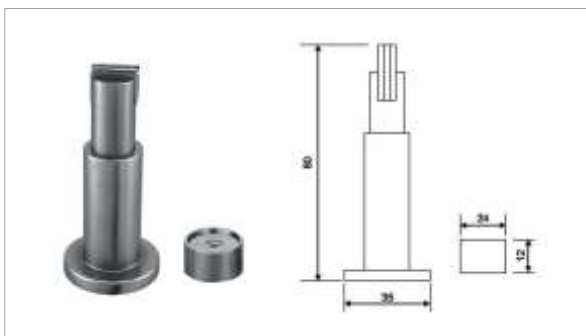

MDS-009BR/ZA



DG0010ZA



DG0020BR



DG0030BR

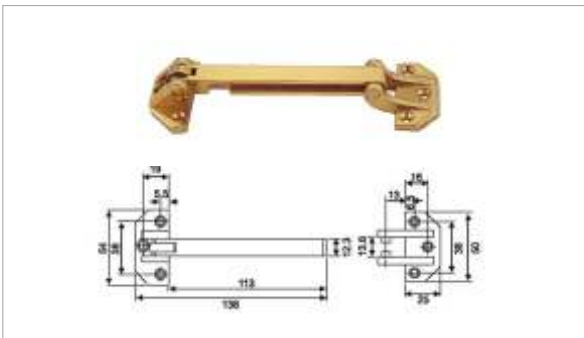

DG0040SS/ZA

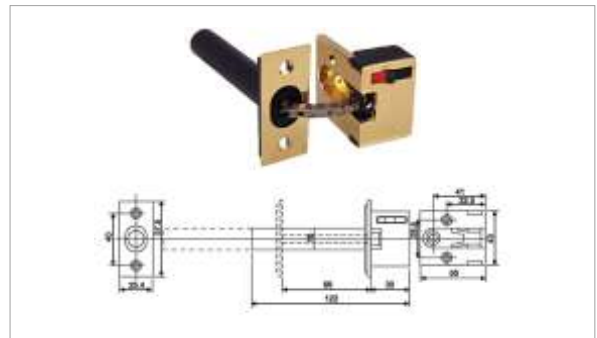

DG0050SS



DG0051ZA



DG0064SS

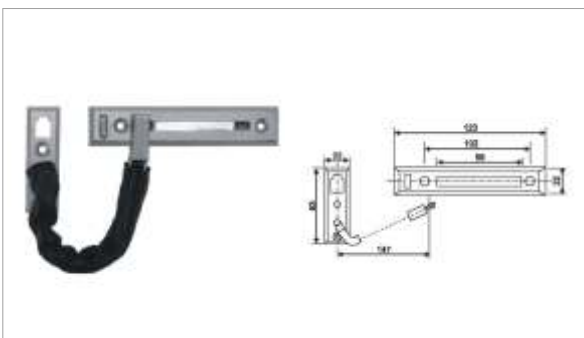

DG0060BR

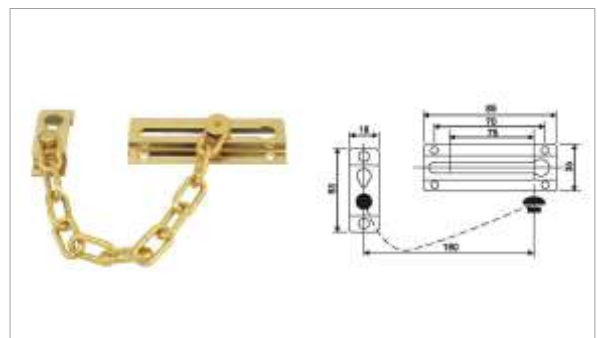

DG0070SS

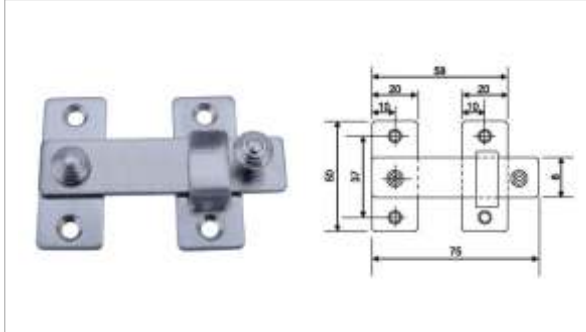

DG0080SS

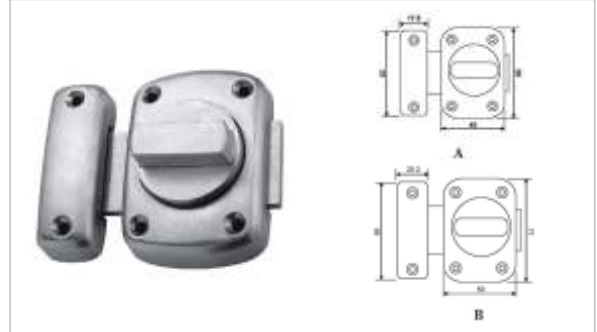

DB001SS(A,B)



DB002SS

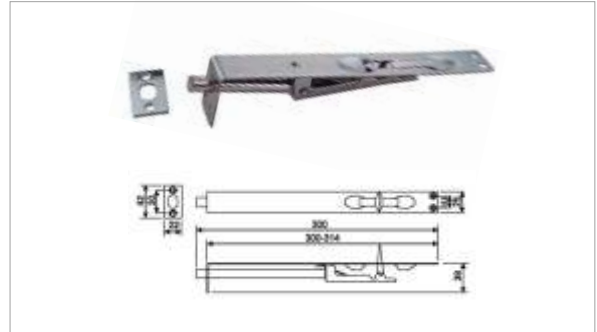

DB003SS(A,B)

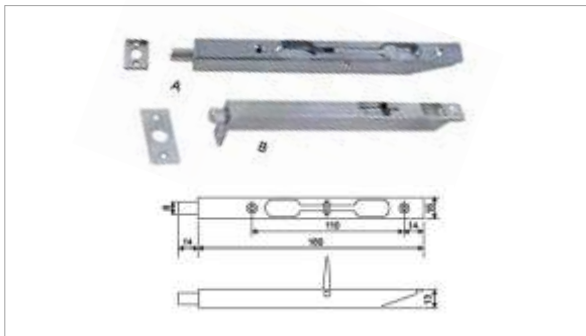

DB004SS/BR

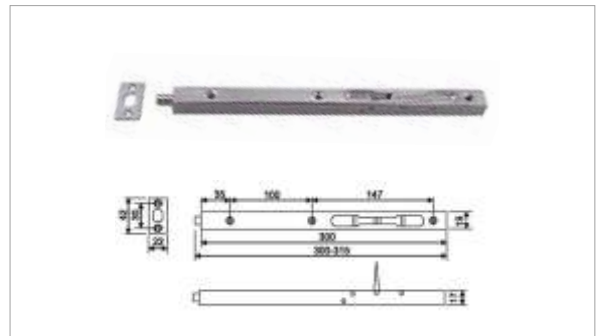

DB005BR

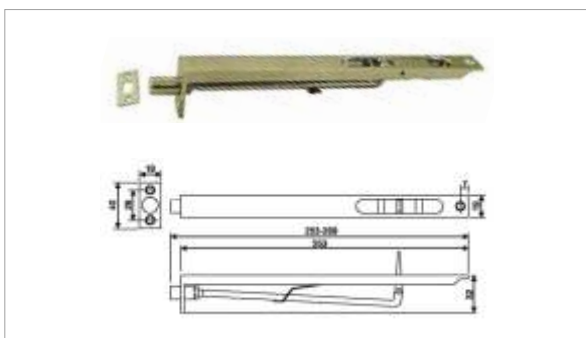

DB006BR

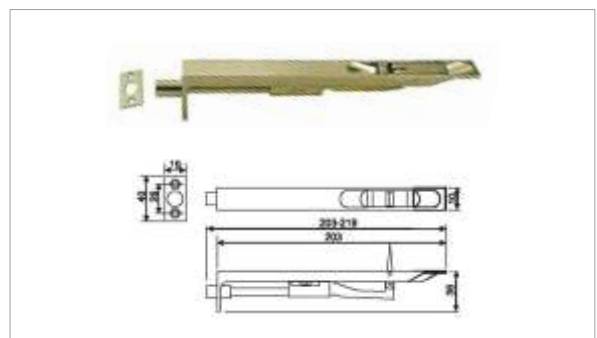

DB007BR

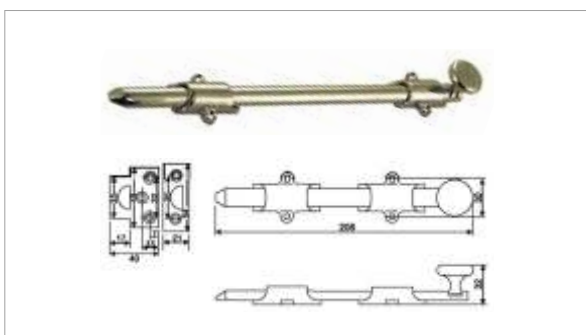

DB008A

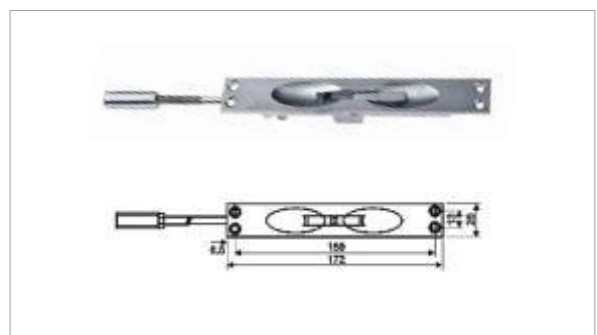

DB008B

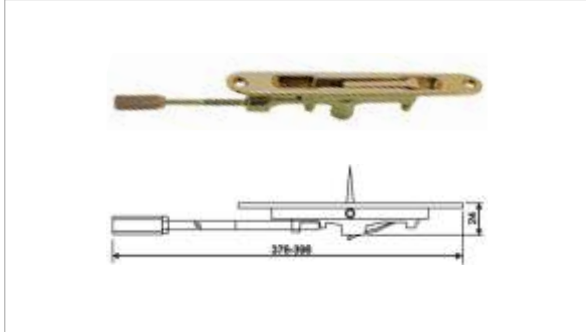

DB008C



DB009SS

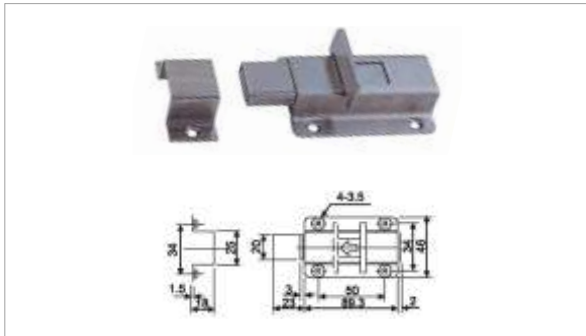

DB010SS

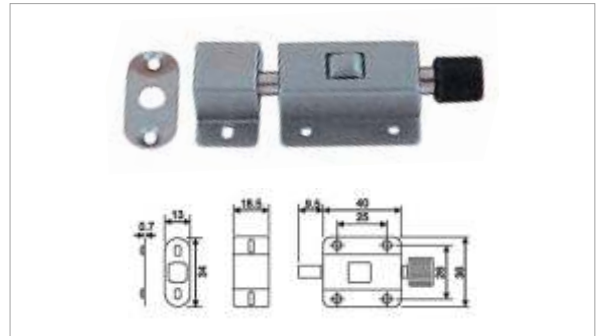

DB011SS

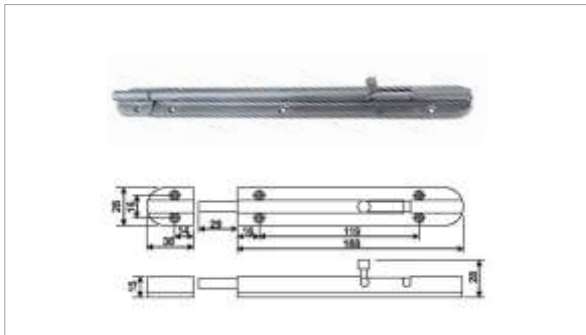

DB012BR

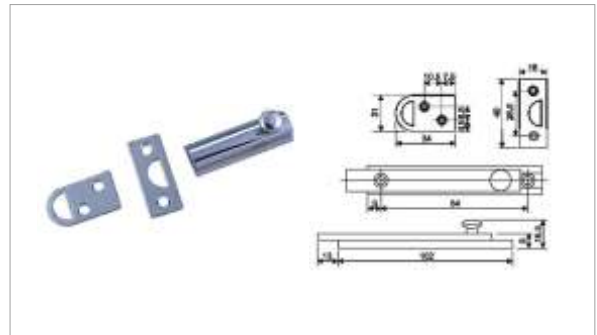

DB013BR

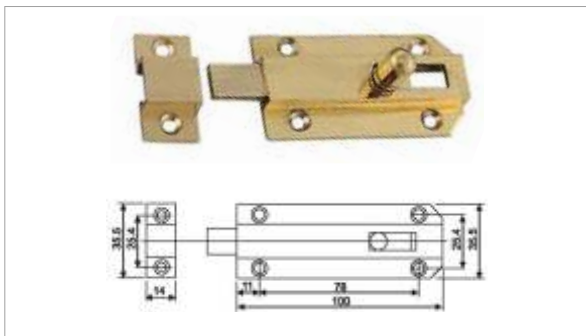

DB014BR

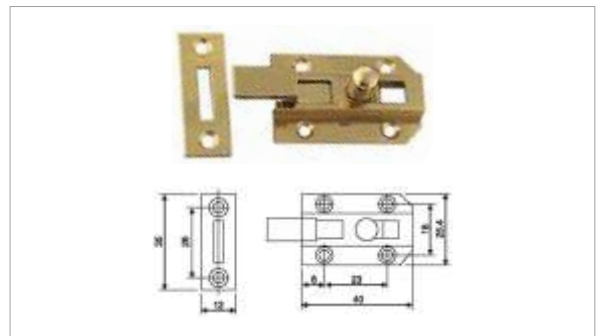

DB015BR

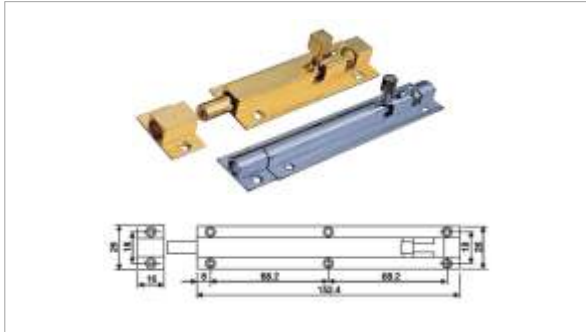

DB016BR

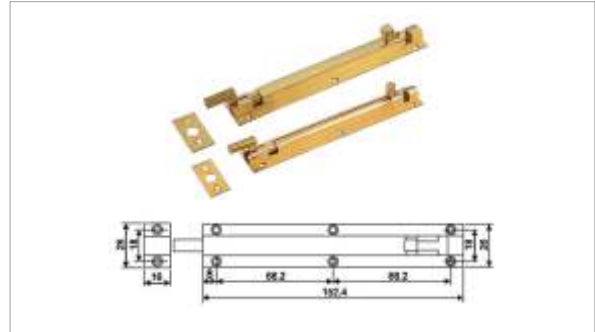

DB017BR

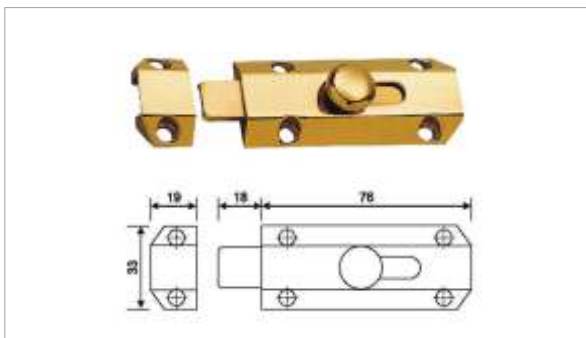

DB018BR



DB019BR



IB005SS

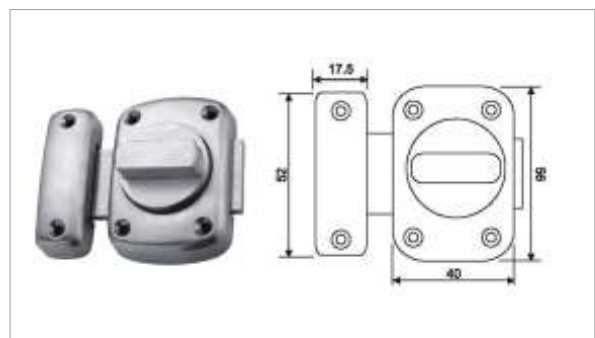

DS001BR

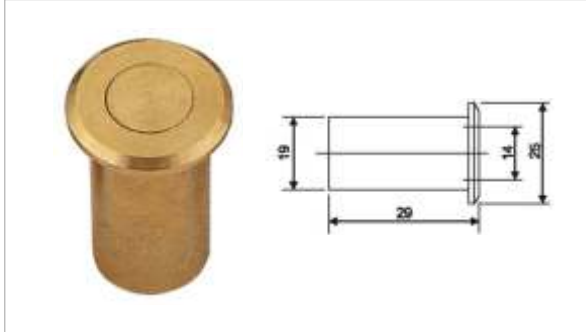

DS002SS/BR



DS003SS



DS004SS



DS005SS



DV160



DV180-L



DV180

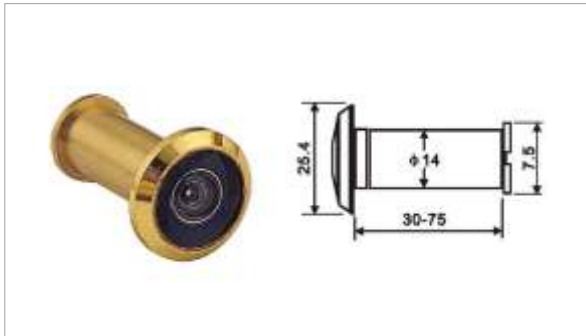

DV200



BC001BR

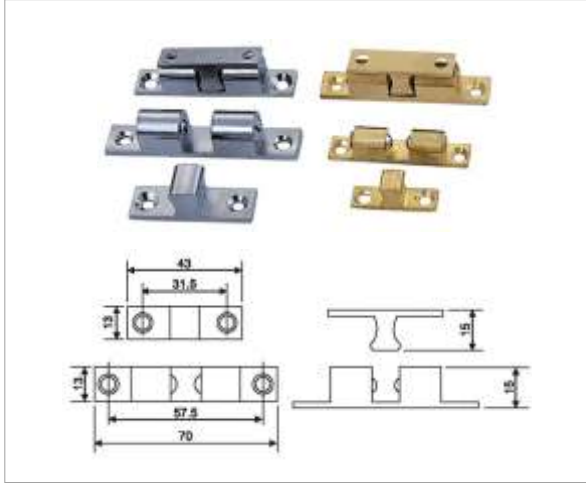

BC002SS

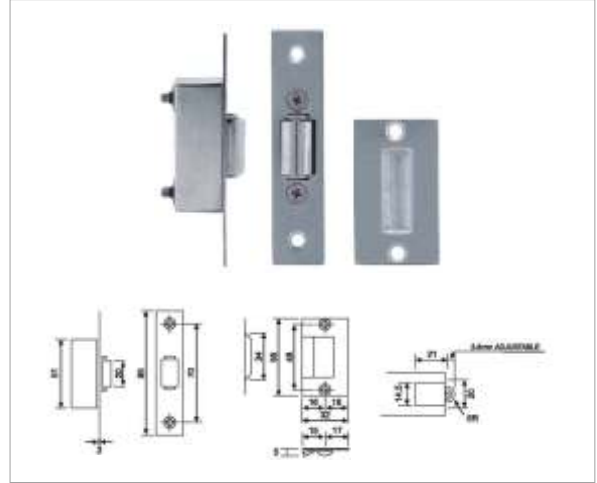

BC003BR

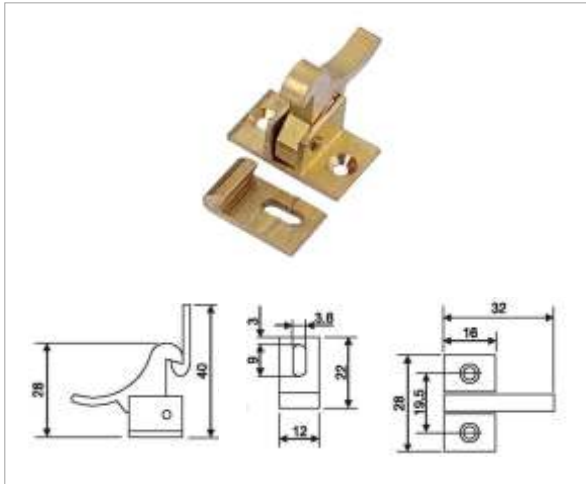

BC004SS

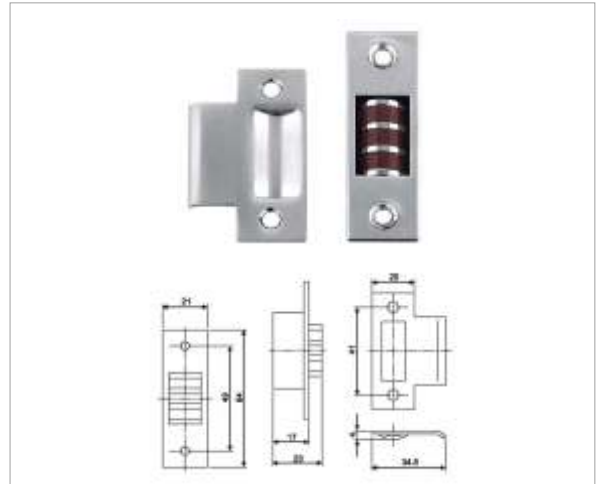

BC005BR



BC006

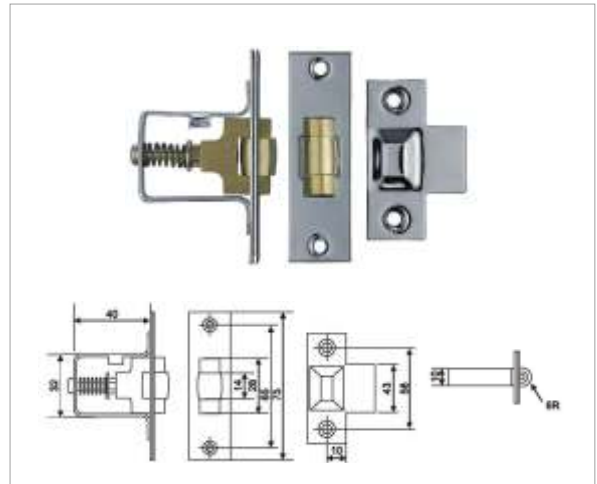

CO-001SS

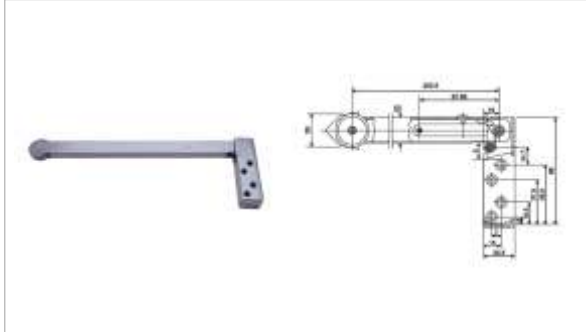

CO-002SS

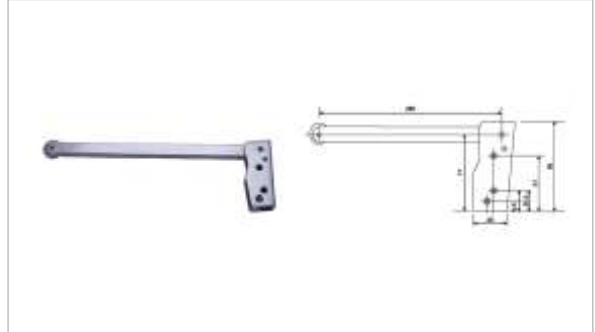

CO-003AL

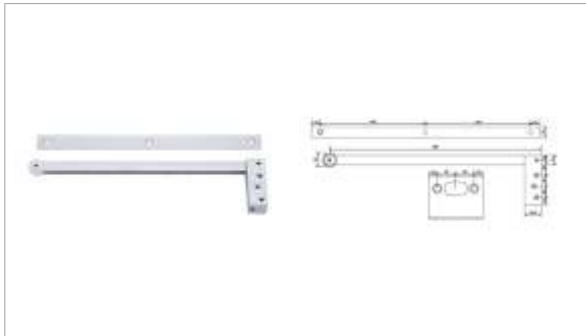

CO-004SS

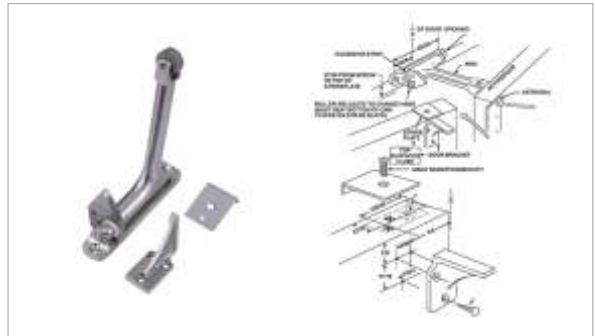

FDB001SS-A

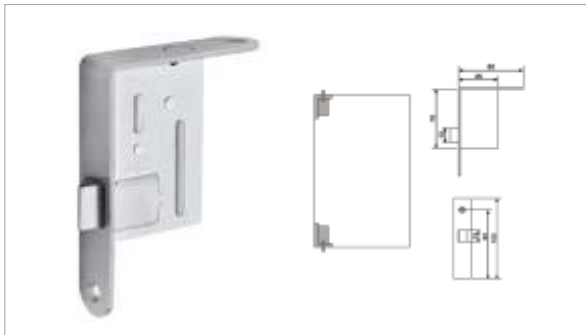

FDB001SS-B

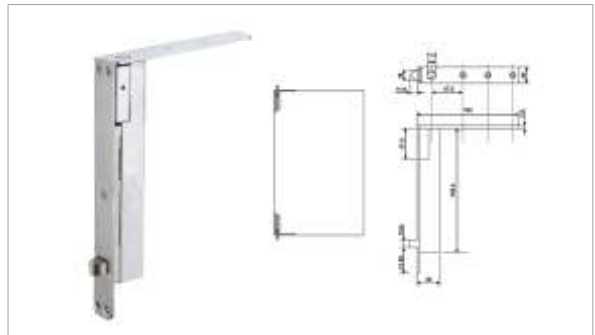

FDB002SS

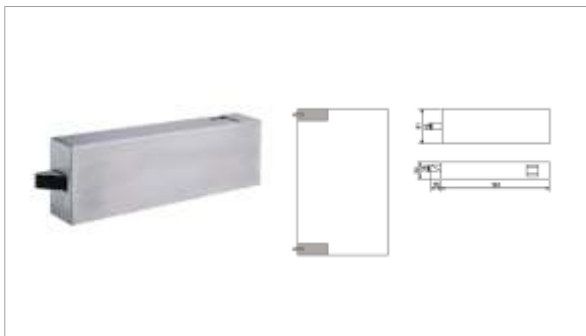

DG0080BR

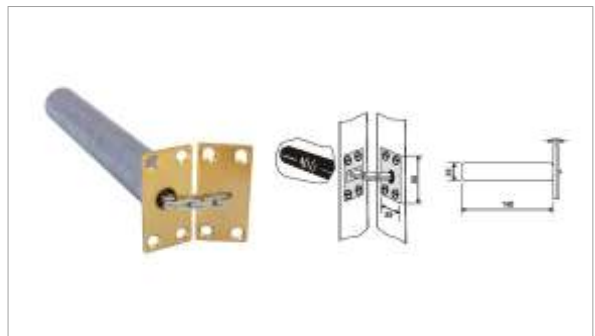

MS-001

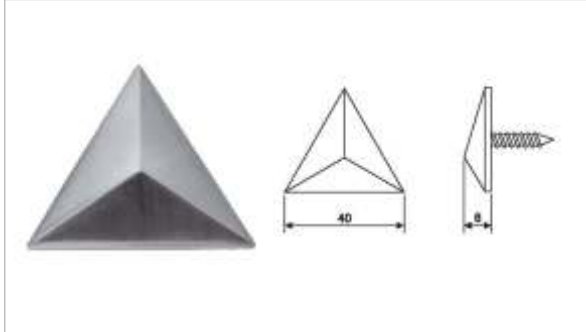

MS-002

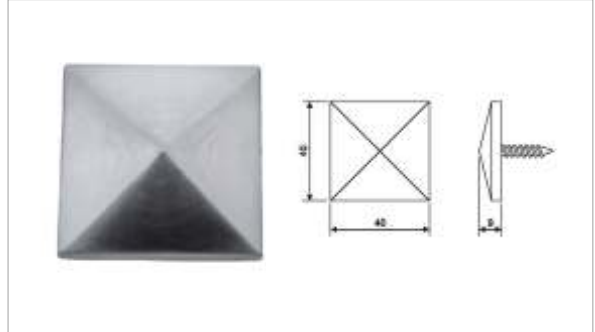

MS-003

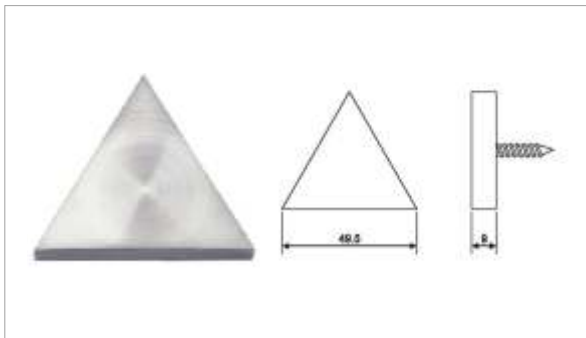

MS-004

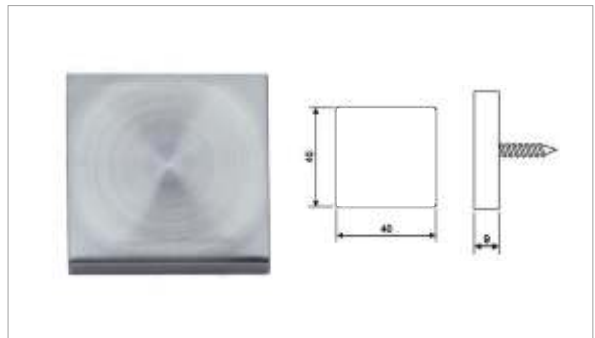

MS-006

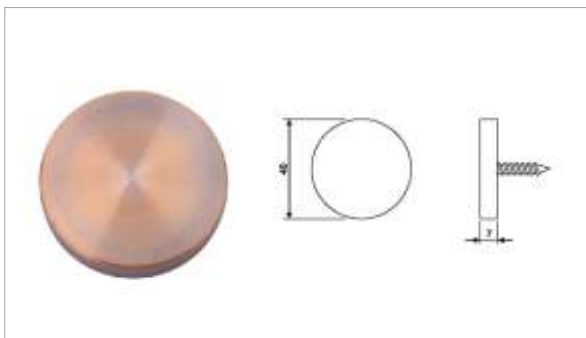

MS-007

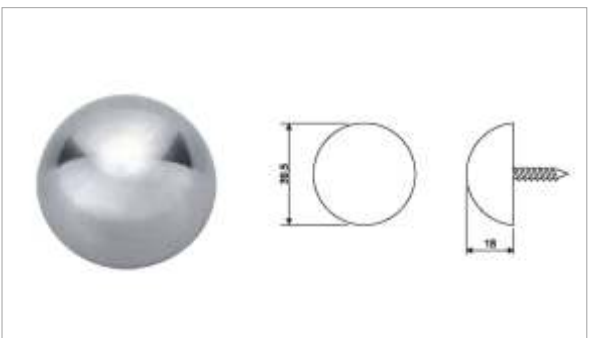

MS-008

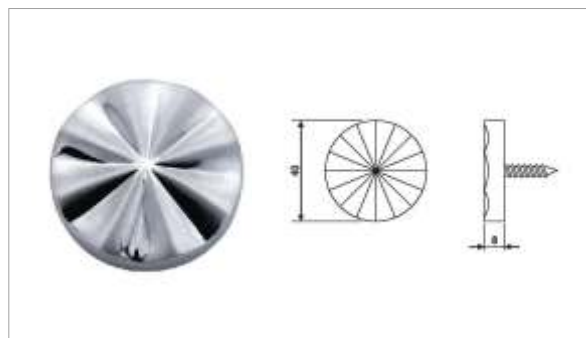

MS-009BR

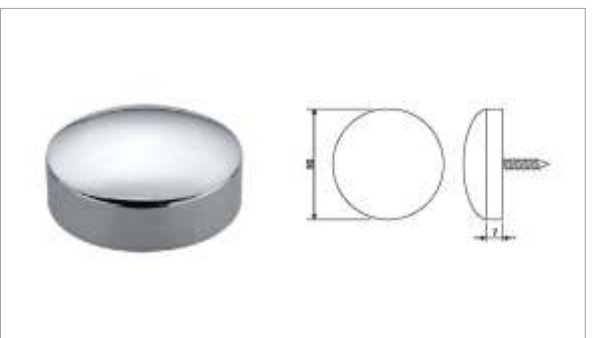

SB001ZA

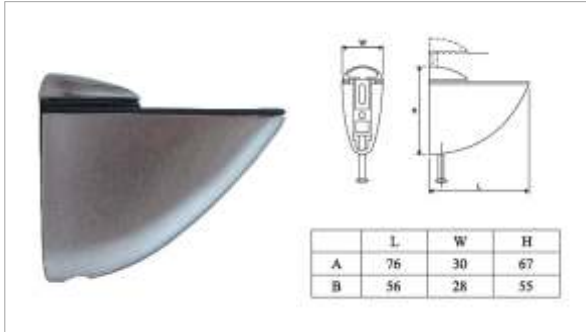

SB002ZA-A



SB002ZA-B

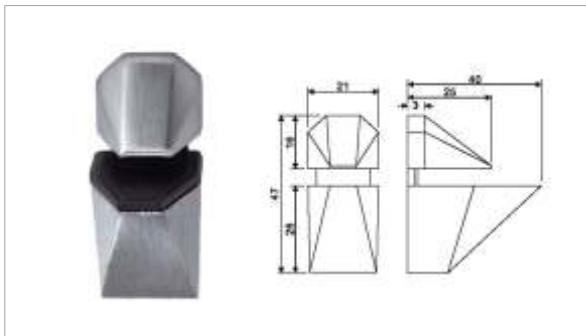

GH001



GH002



SDB001

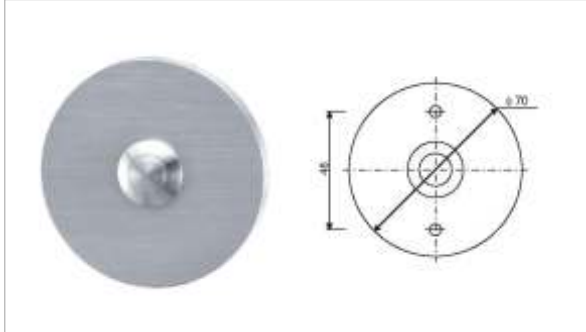

SDB002

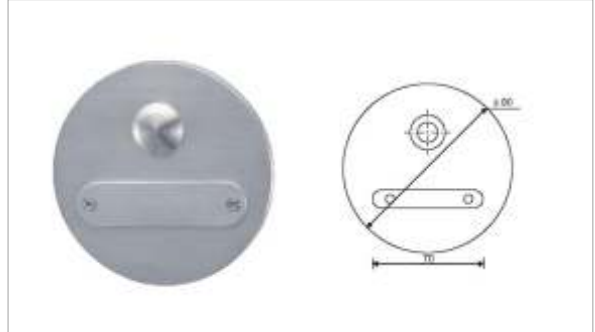

SDB003

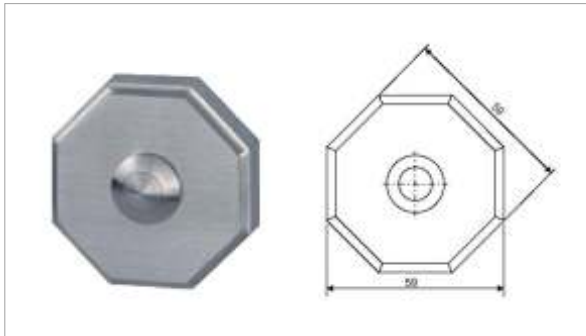

SDB004

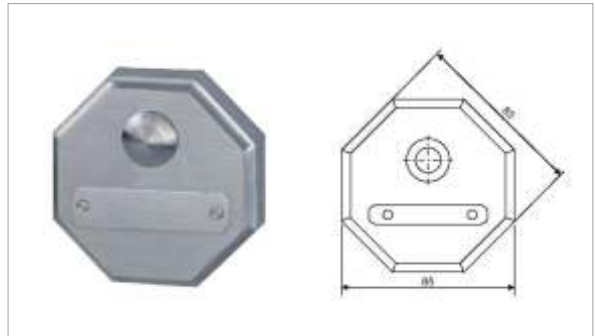

SDB005

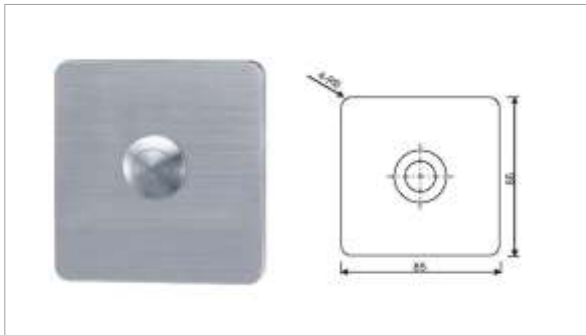

SDB006

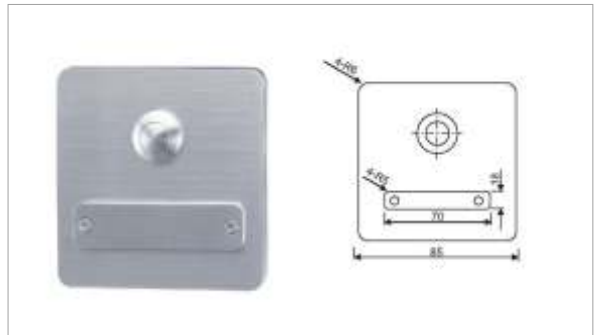

SDB007

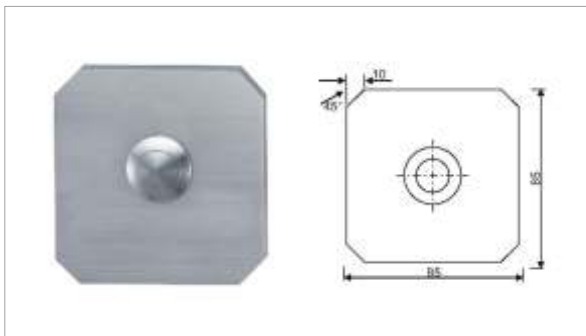

SDB008

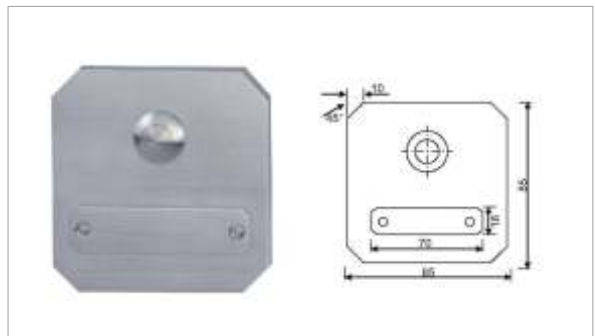

LER0010A



LER0010B



LER0010C



LE001SS

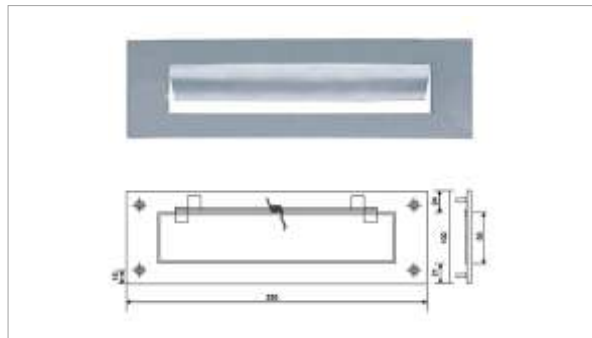

LE002SS



MB-001



MB-002

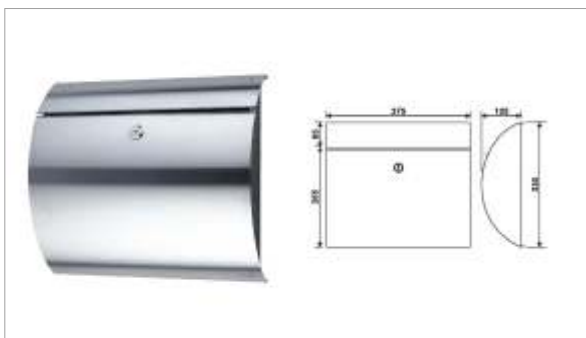

MB-003

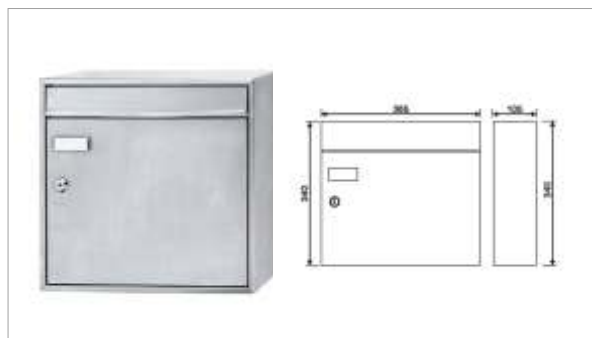

MB-004



MB-005



MB-006



MB-007



MB-007-A



MB-007-B



MB-008



MB-009

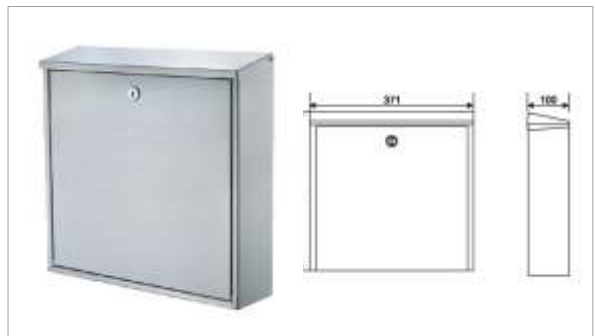

MB-009-B



MB-010



STS-001

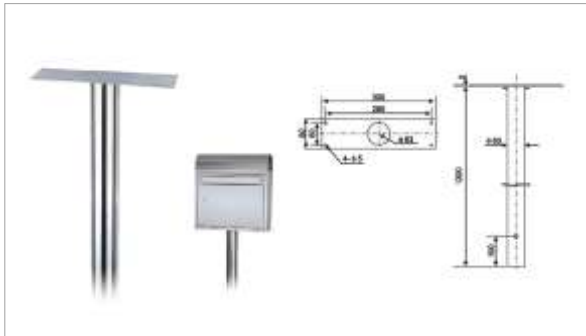

DTS-001

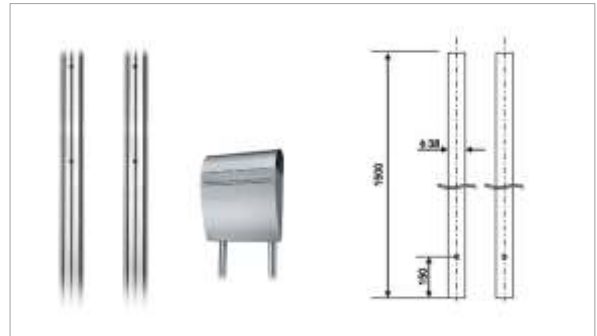

FH0010SS/BR

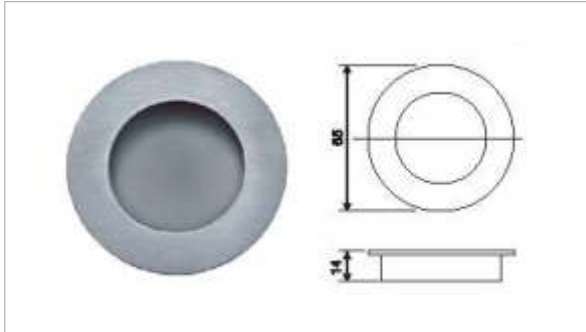

FH0020SS

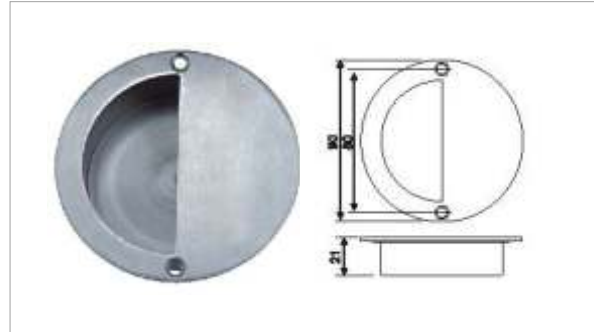

► This product size can be customized.

FH0030SS

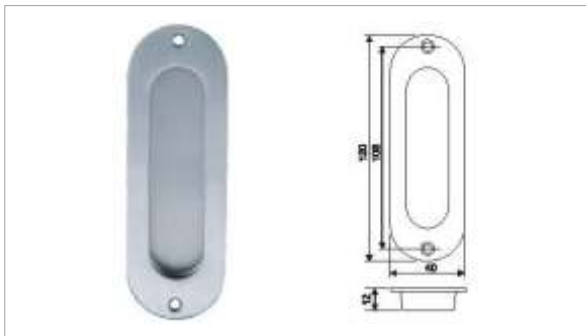

FH0040SS

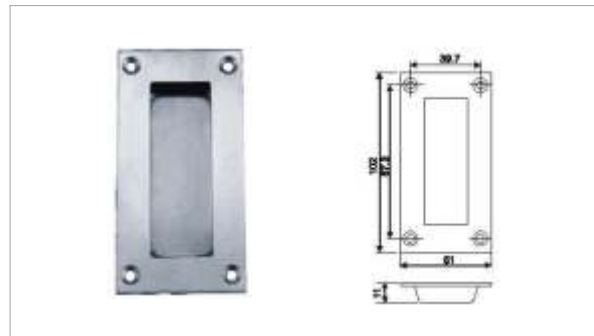

FH0041SS



FH0042SS

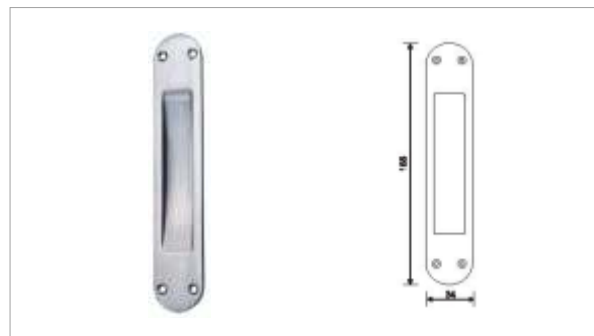

FH0043SS

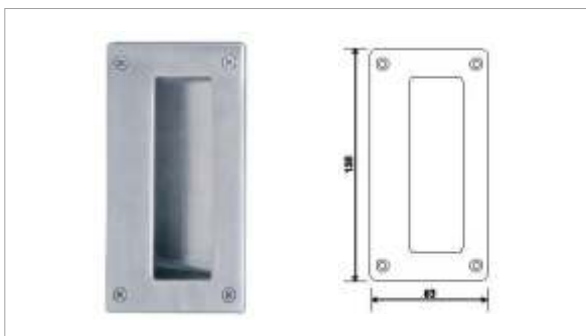

FH0044SS

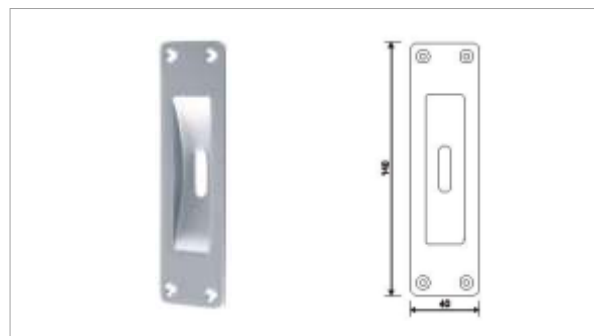

FH0045SS

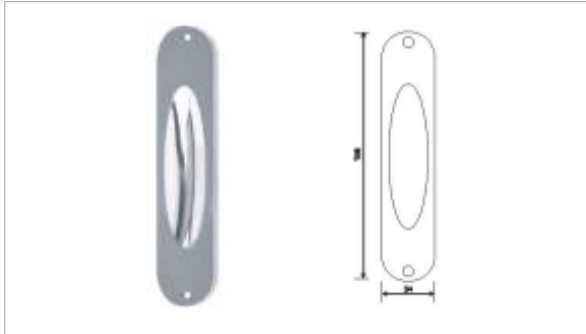

FH0046SS

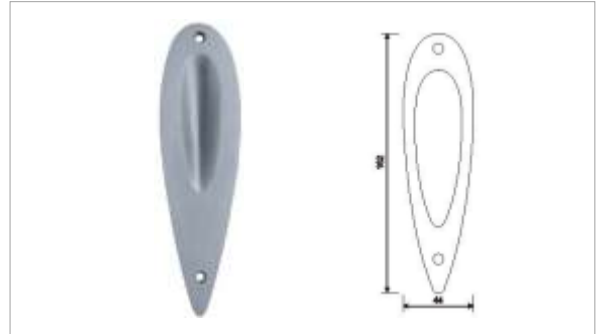

FH0047SS



FH0048SS

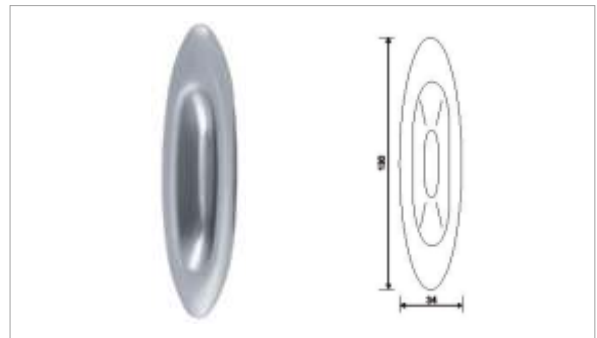

FH0049ZA



FH0050SS

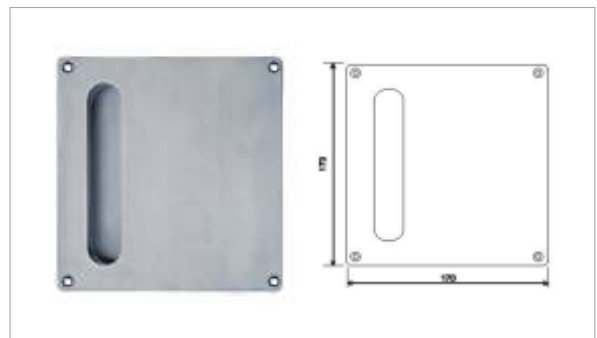

FH0051SS



FH0052BR



FH0053SS



FH0054SS

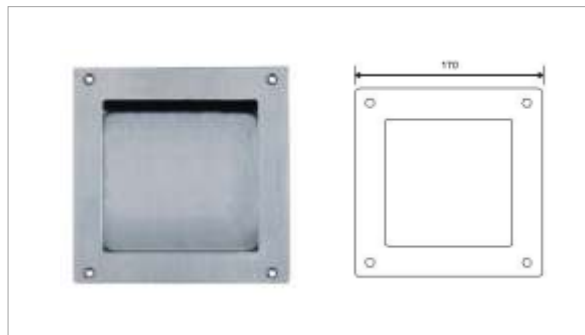

FH0055SS

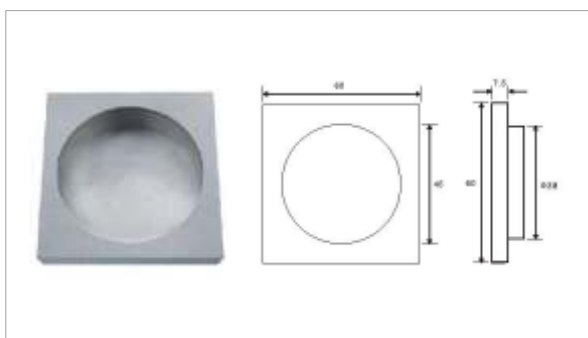

FLK001

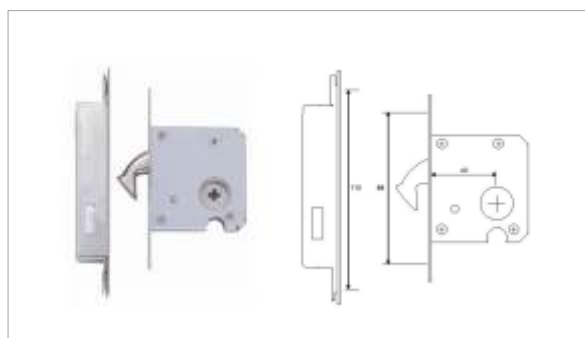

FL001ZA/BR



FL002ZA/BR

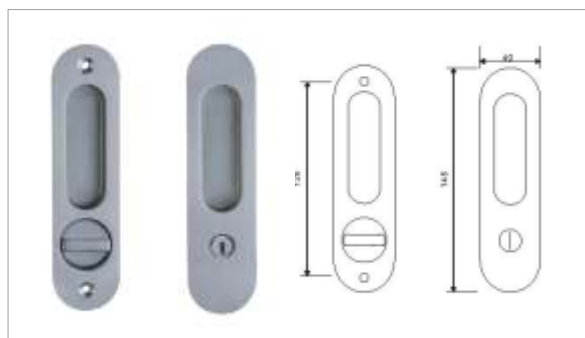

FL005ZA/BR



FL004ZA/BR



FH005SS



FH006SS

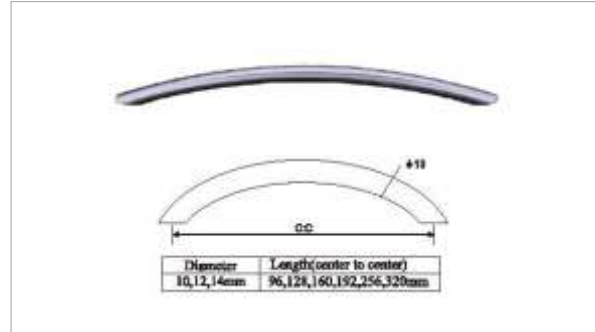

FH007SS



FH008SS

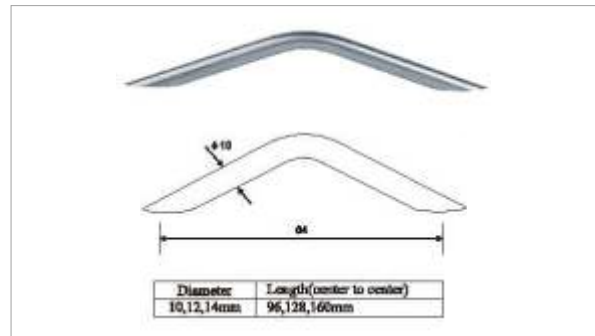

FH009SS



FH010SS



FH011SS



FH0281SS

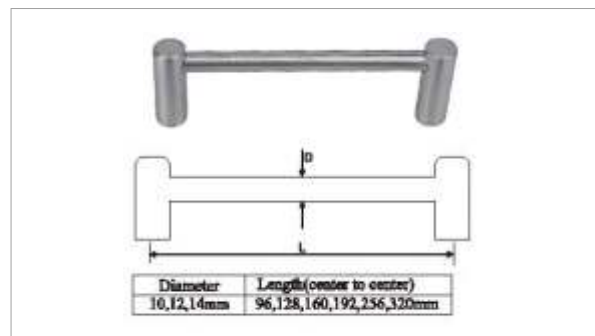

FH033SS



FH034SS



FH035SS/BR

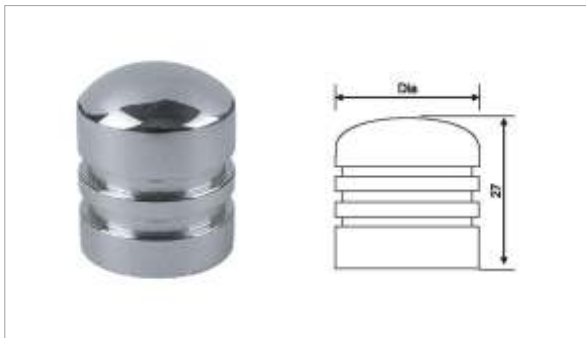

FH036SS/BR

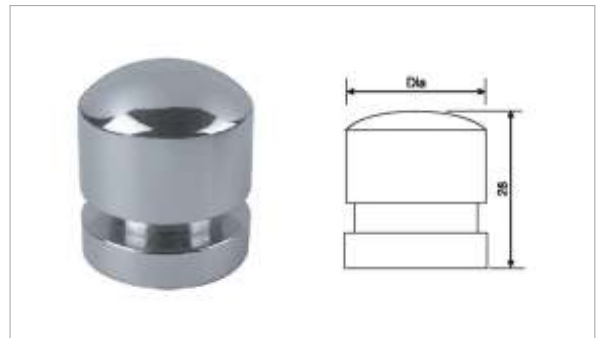

FH037SS/BR



FH038SS/BR



FH039SS/BR



FH040SS

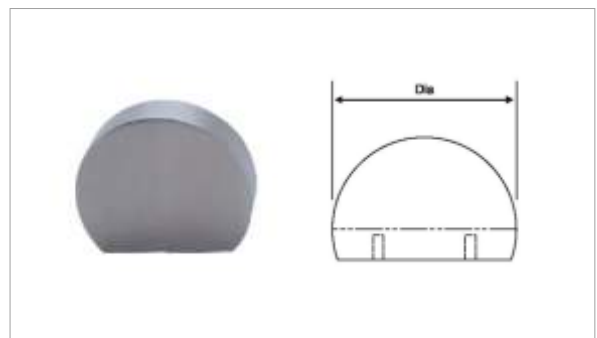

DCH0290SS

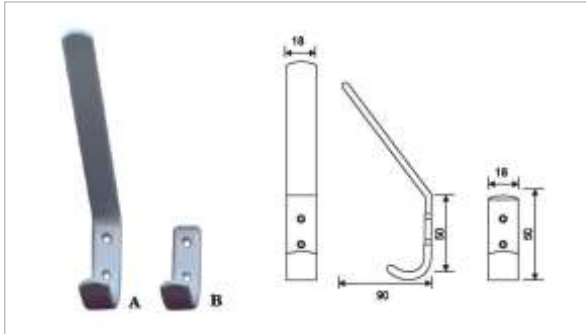

DCH0320SS/BR

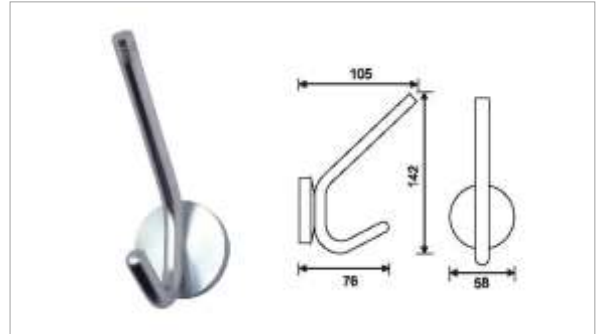

DCH0350BR



DCH0410BR

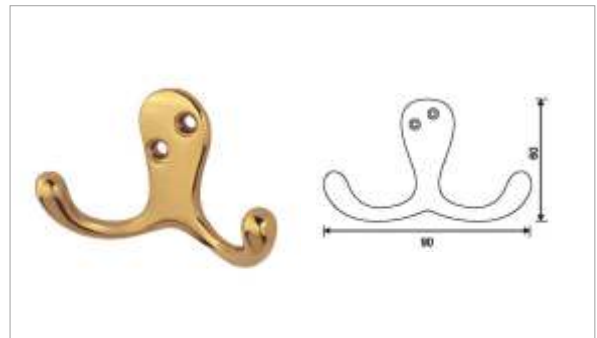

DCH0420SS/BR

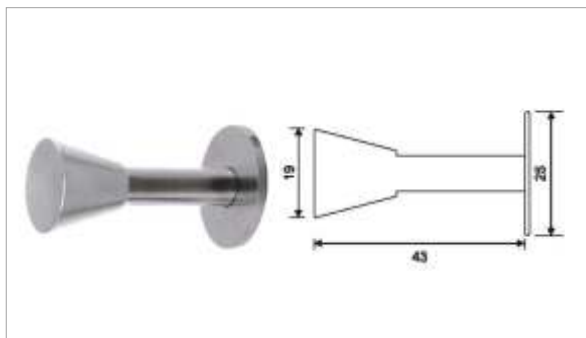

DCH0430SS/BR



DCH0440SS/BR

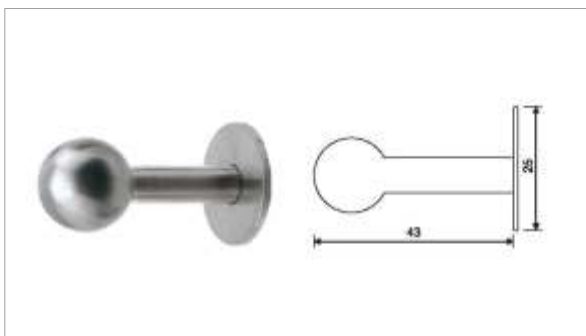

DCH0560SS

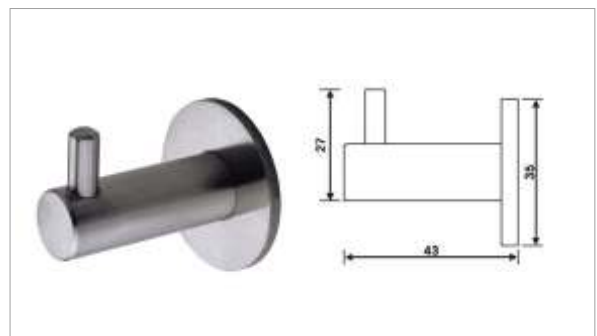

DCH0570SS



DCH0580SS

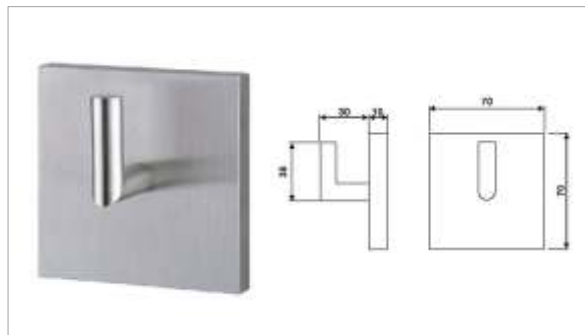

CHP-1102-SS

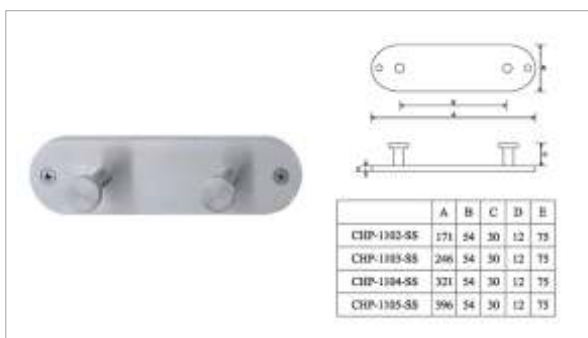

CHP-1103-SS

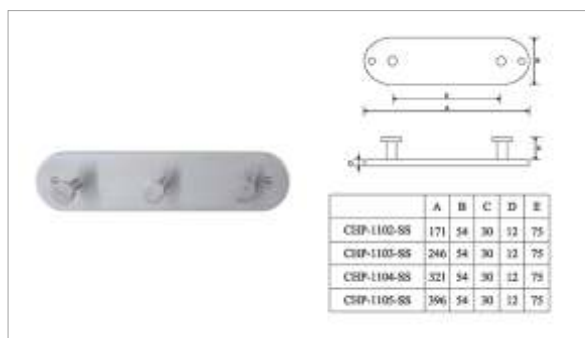

CHP-1104-SS

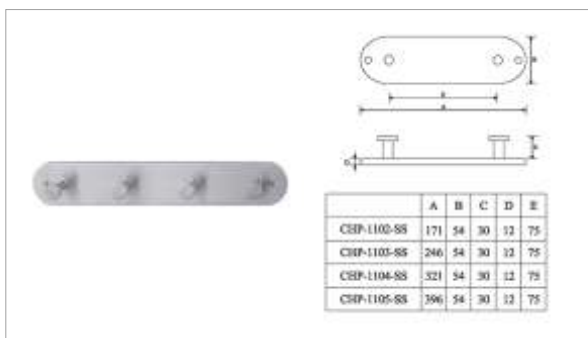

CHP-1105-SS

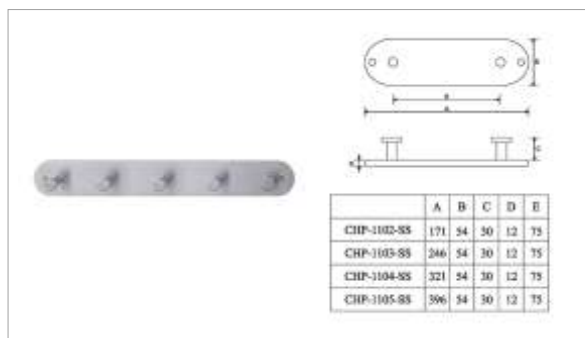

CHP-1202-SS

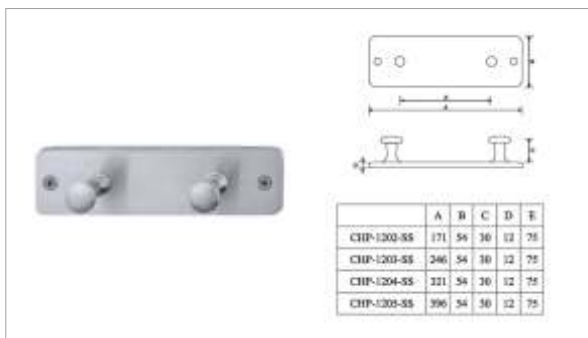

CHP-1203-SS

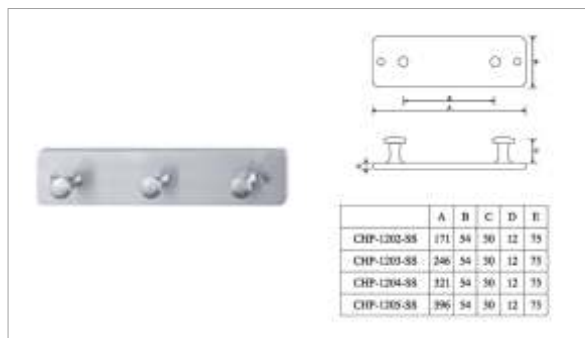

CHP-1204-SS

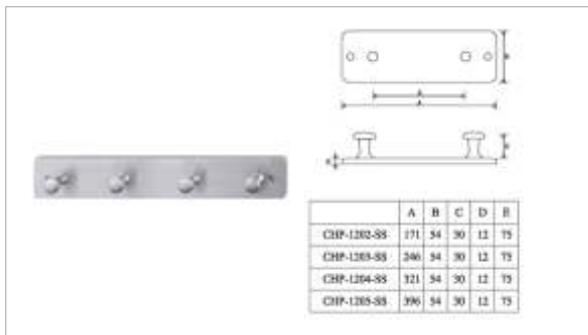

CHP-1205-SS

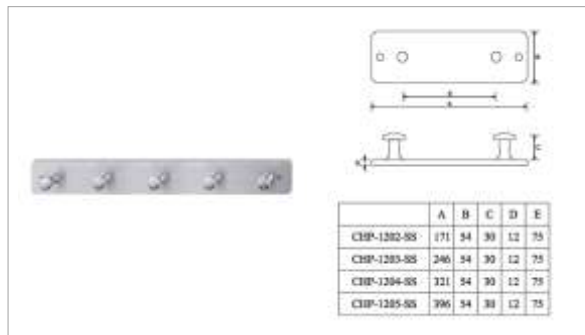

CHP-1302-SS

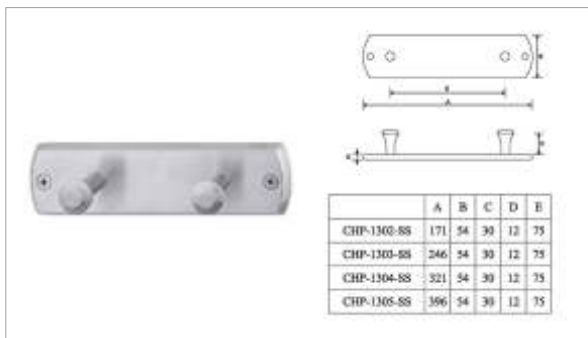

CHP-3104-AL

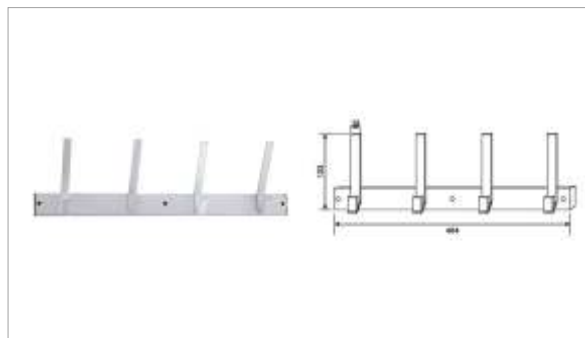

SCH0010SS

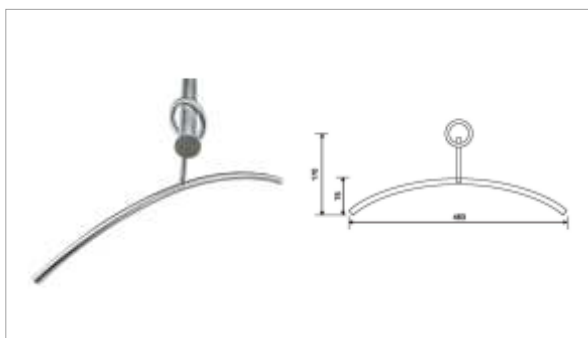

SCH0011SS

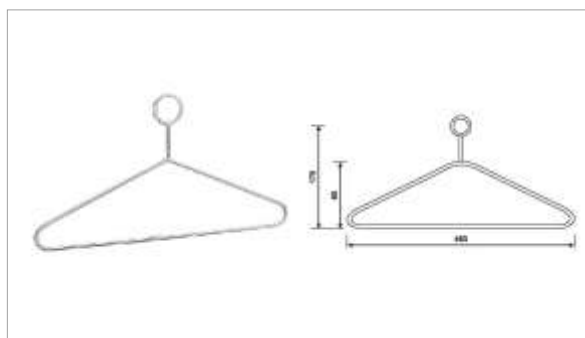

SCH0020SS

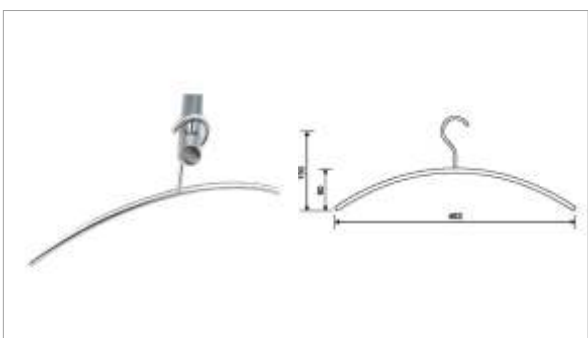

SCH0012SS

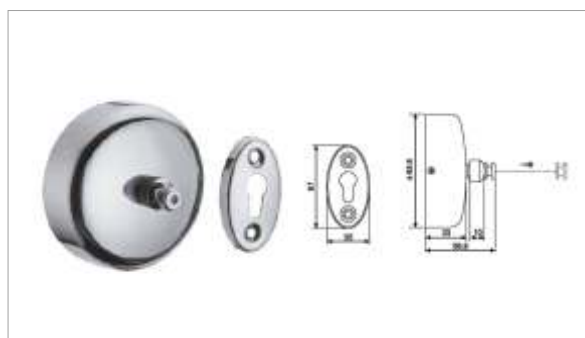

SCH0030SS



SCH0040SS



SCH0050SS

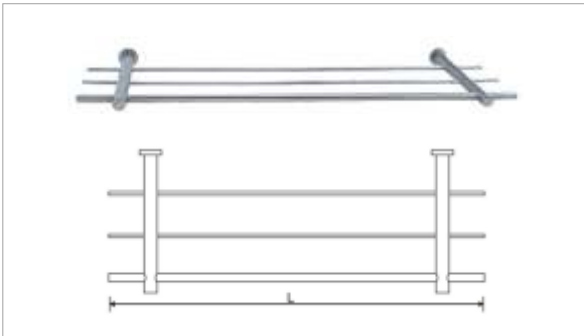

SCH0060SS

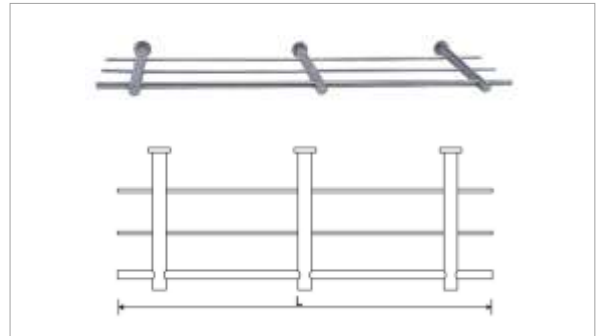

HW-101A

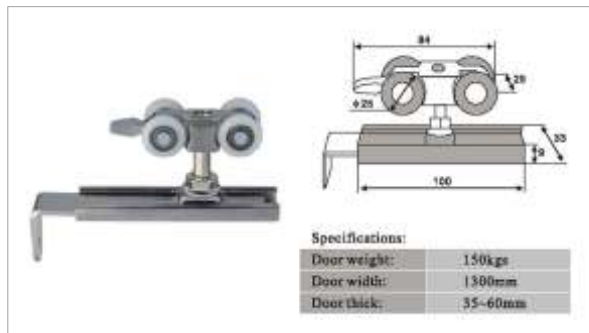

HW-101B

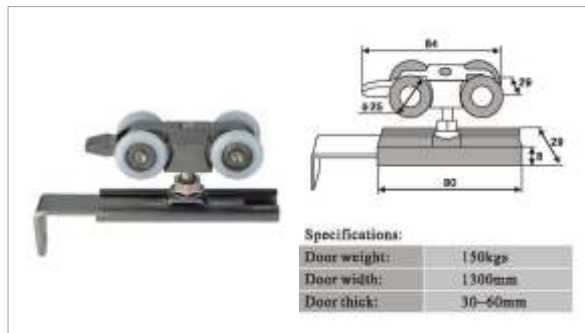

HW-101C

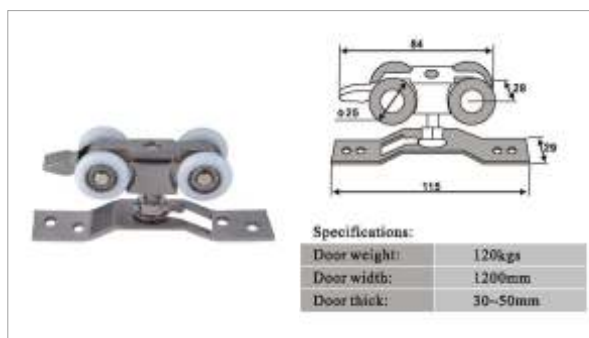

HW-201A

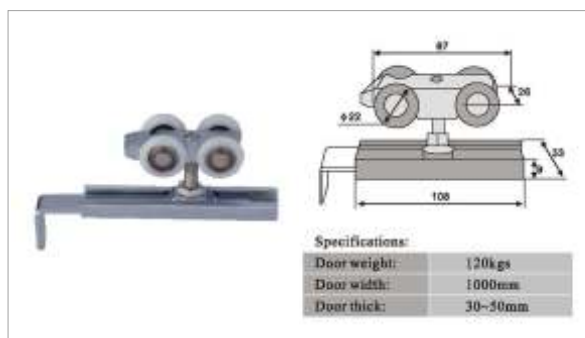

HW-201B

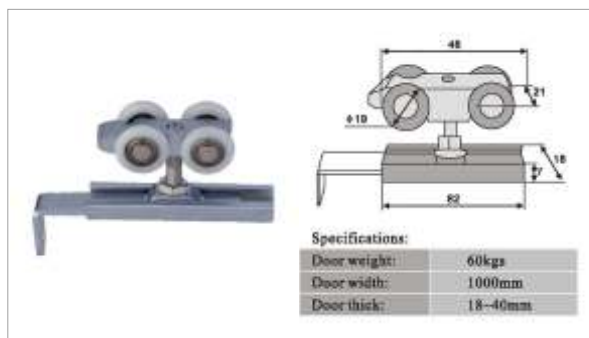

HW-201C

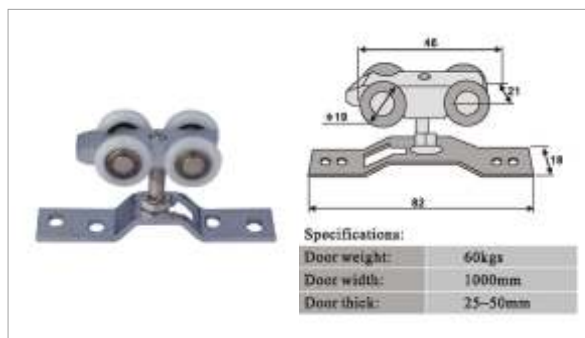

HW-301A

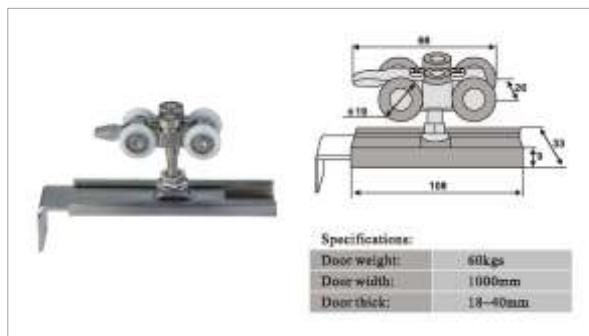

HW-301B

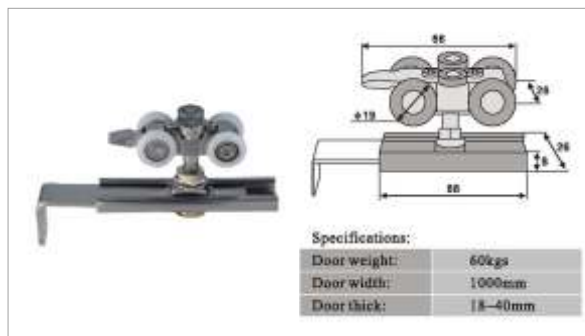

HW-301C

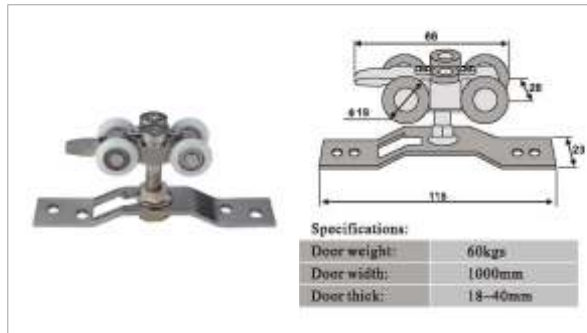

HW-401A

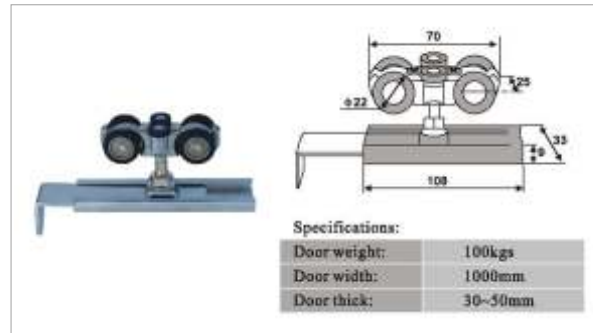

HW-401B

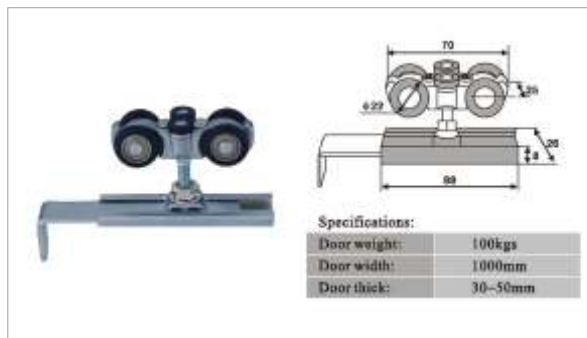

HW-401C

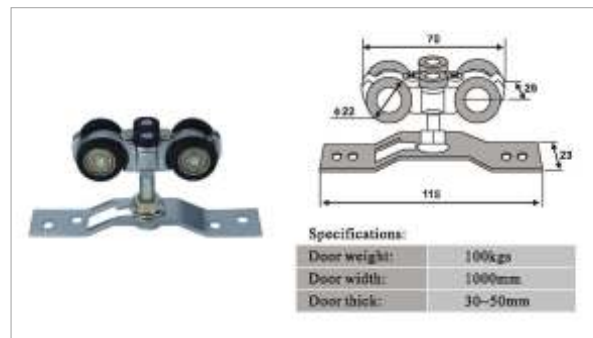

HW-9905

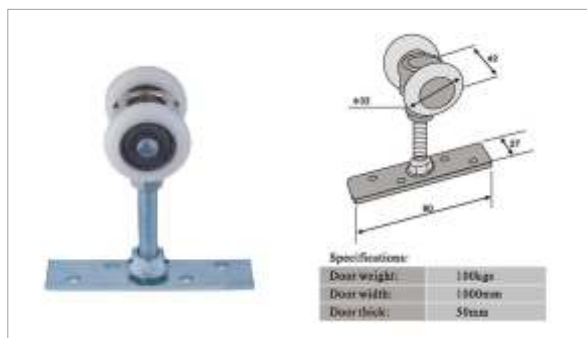

HW-9906

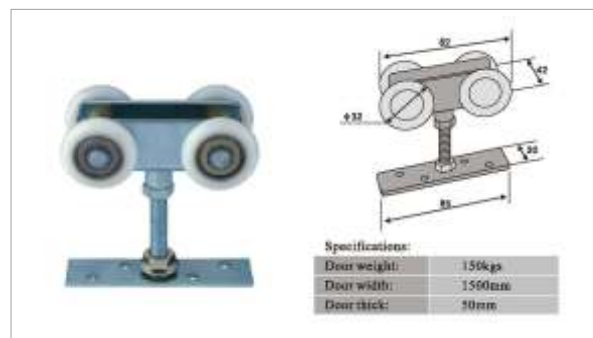

HW-701D

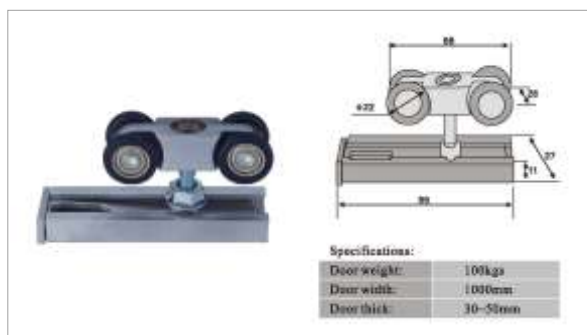

HW-09(A, B)

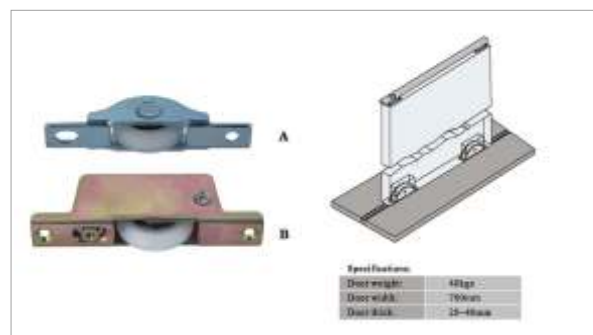

HW-010



HW-302

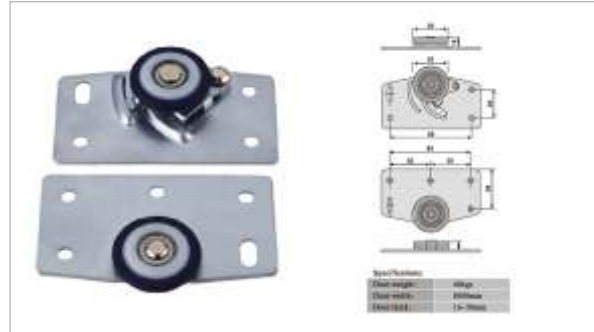

HW-403(A, B)

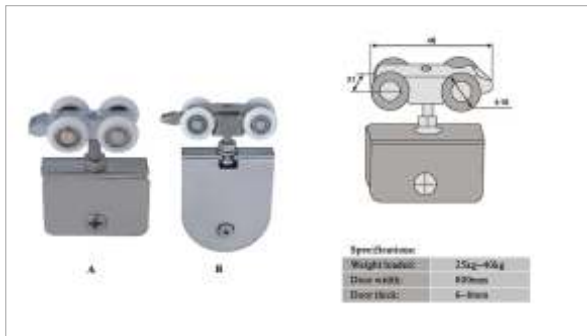

HW-20011

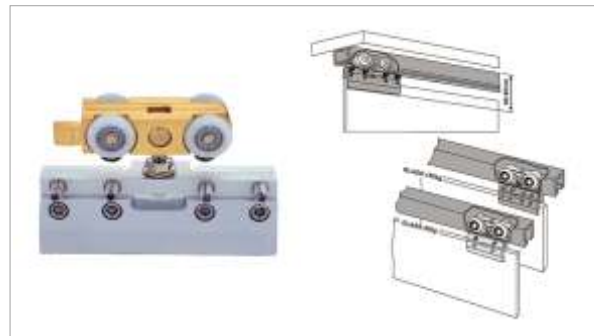

HW-20012



HW-20013

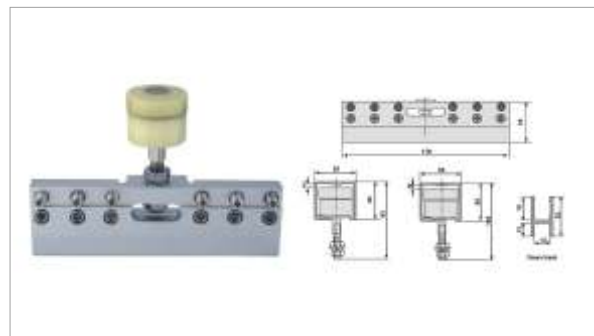

HW-20014



TR-201

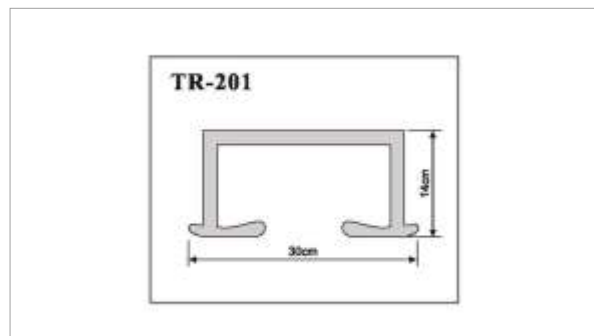

TR-301

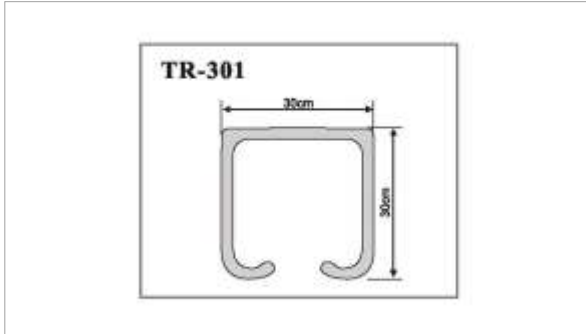

TR-401

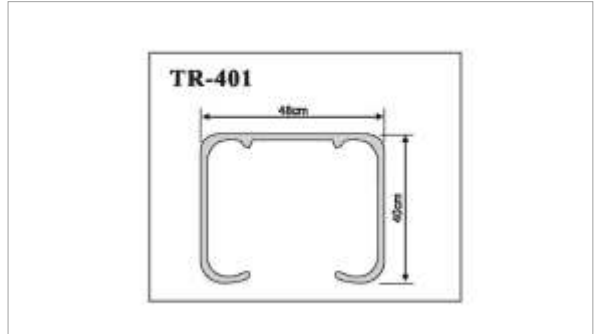

TR-402

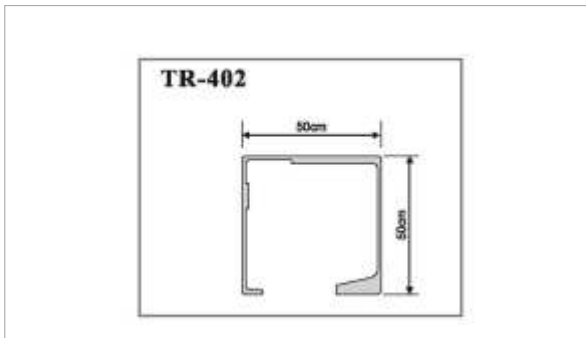

TR-501

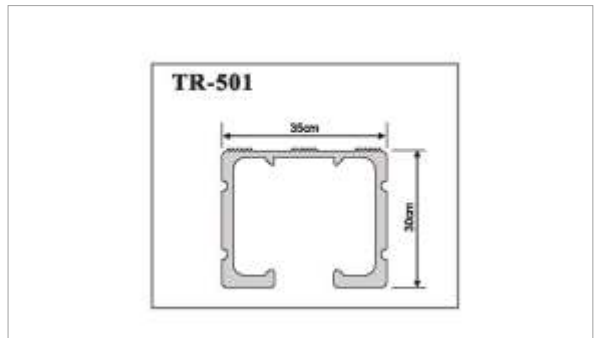

TR-403

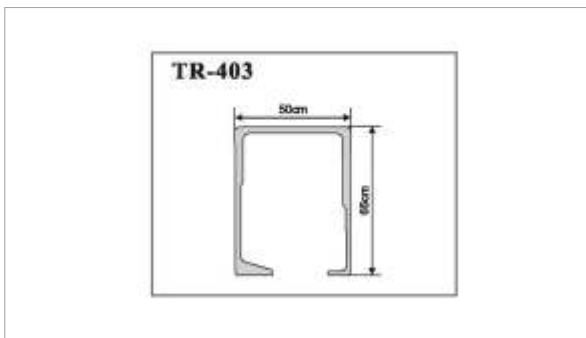

TR-601

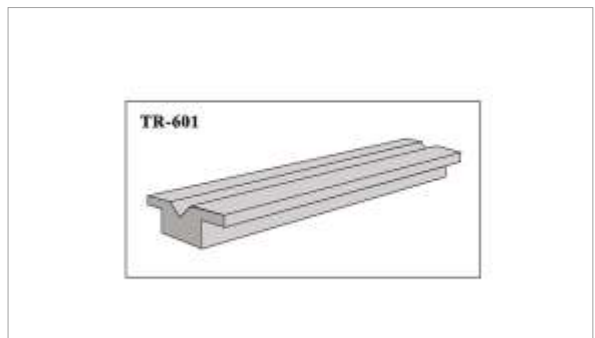

TR-601

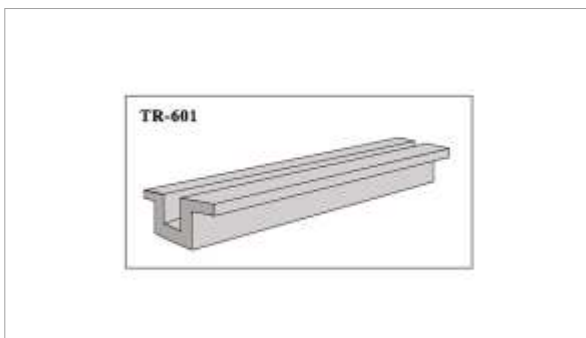

TR-801

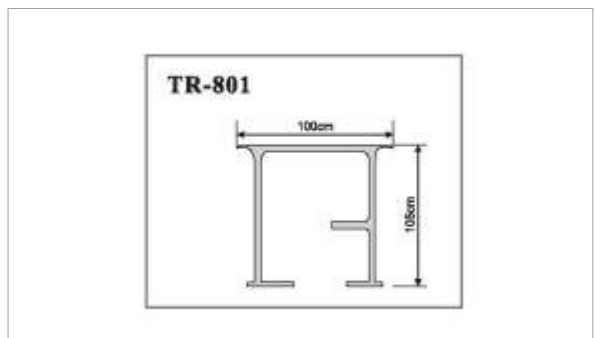

TR-211



TR-902



TR-701

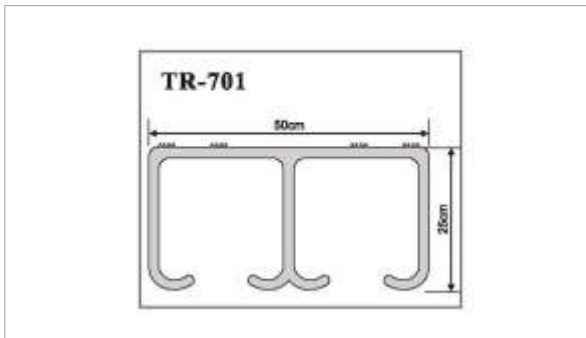

TR-702

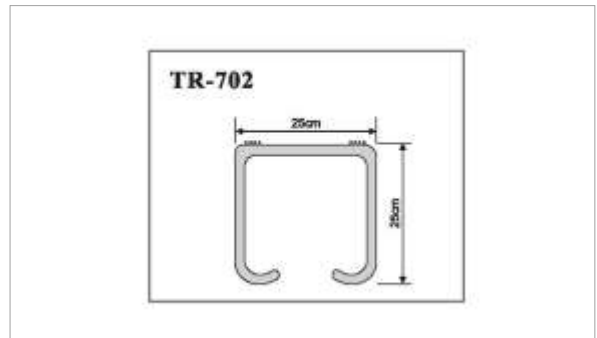

TR-901

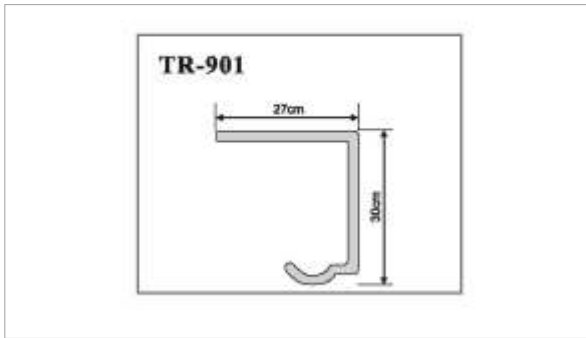

A

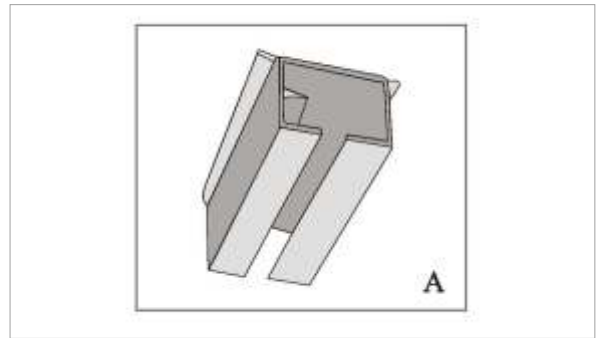

B

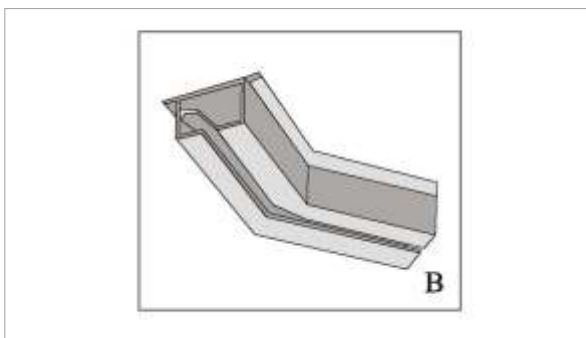

C

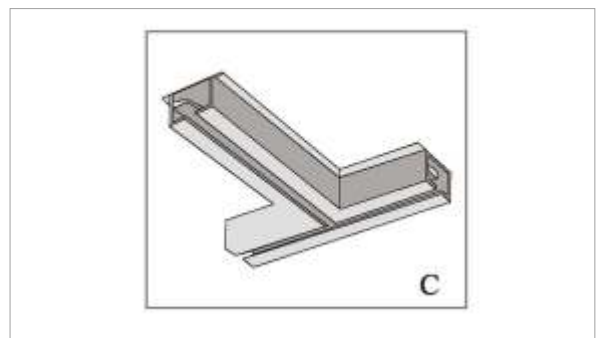

D

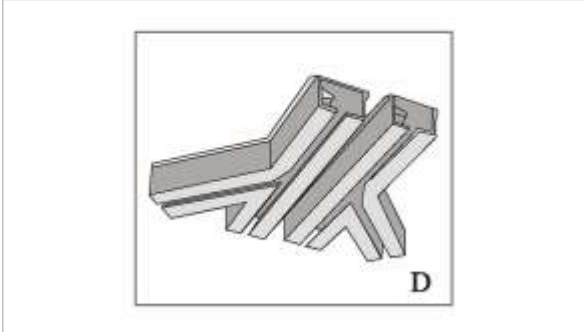

E



F

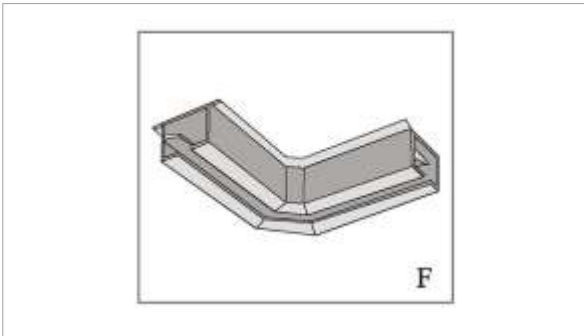

G

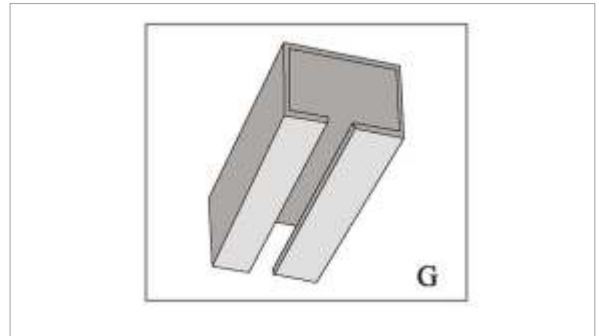

H

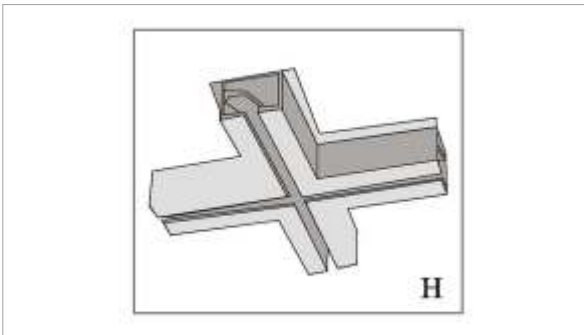

CD-001

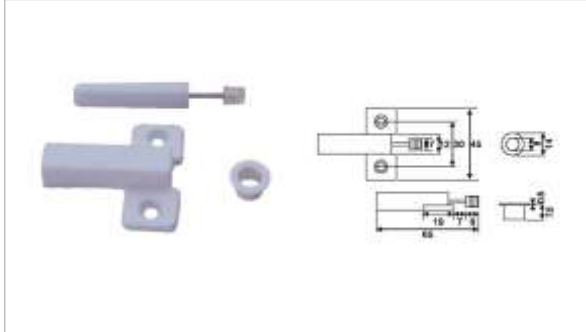

DS-101(A, B)

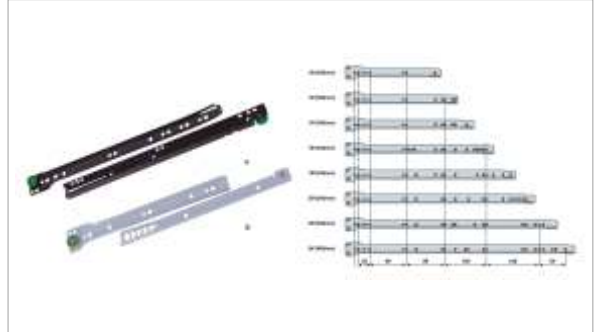

DS-102

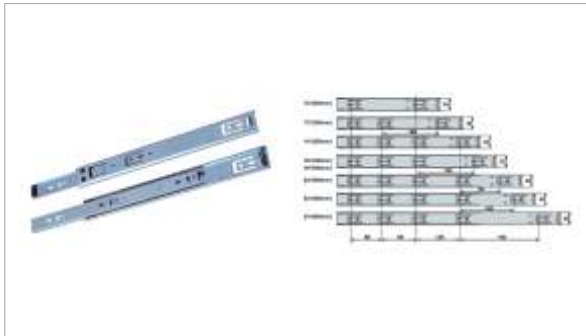

DS-103

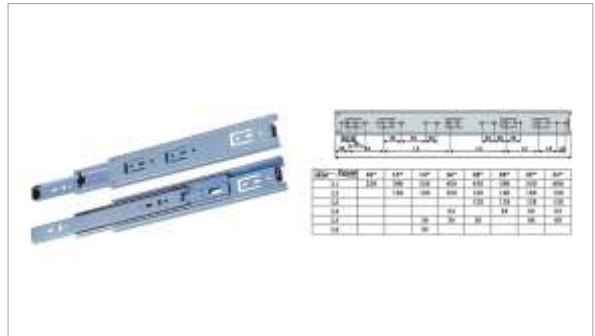

FCH-101A

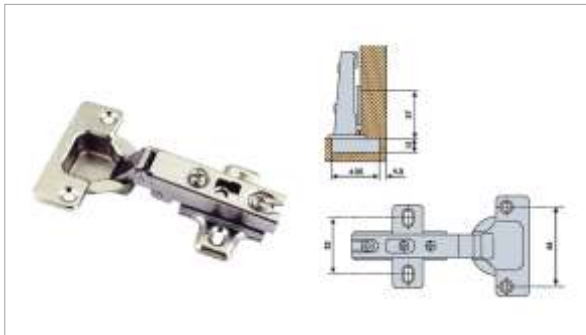

FCH-101B

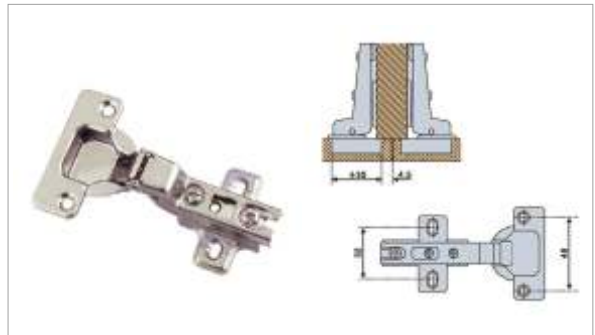

FCH-101C

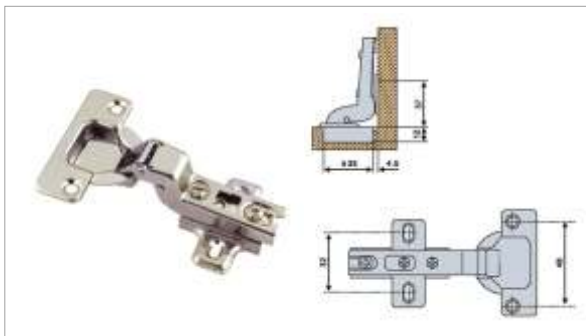

FCH-102A

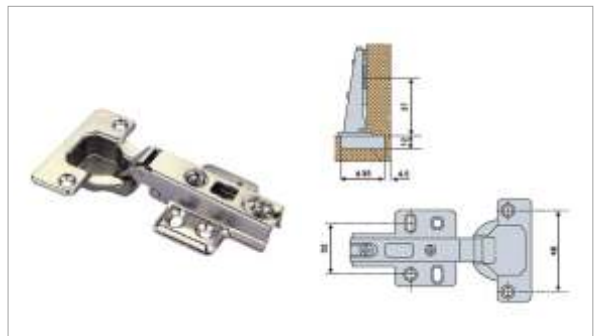

FCH-102B

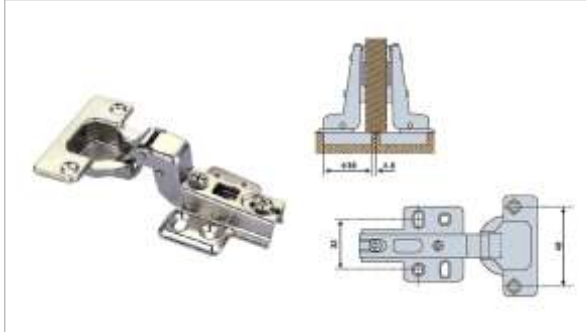

FCH-102C

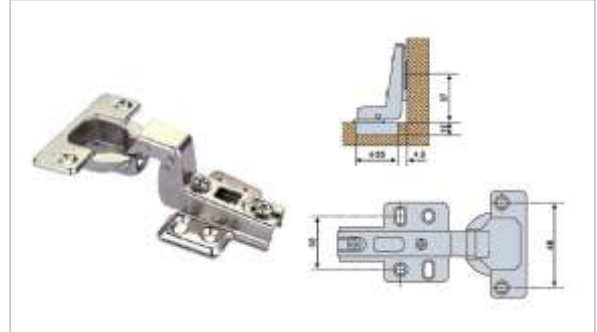

FCH-201A

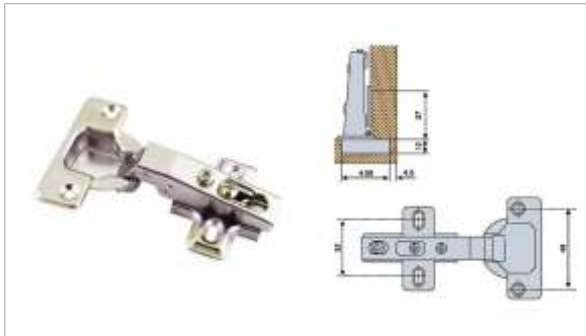

FCH-201B

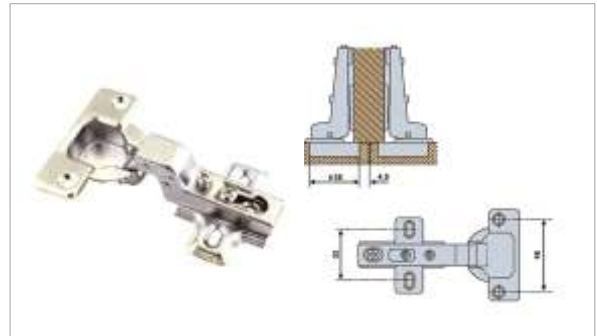

FCH-201C

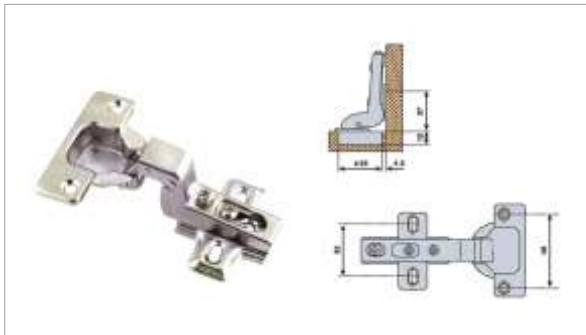

FCH-202A

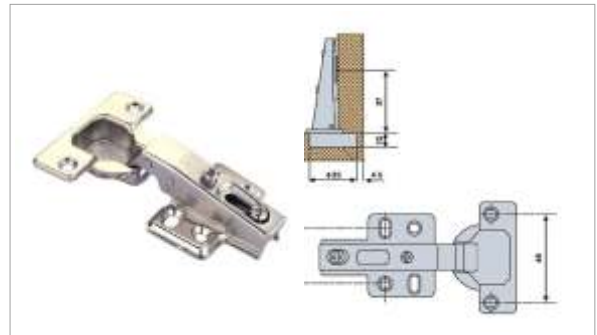

FCH-202B

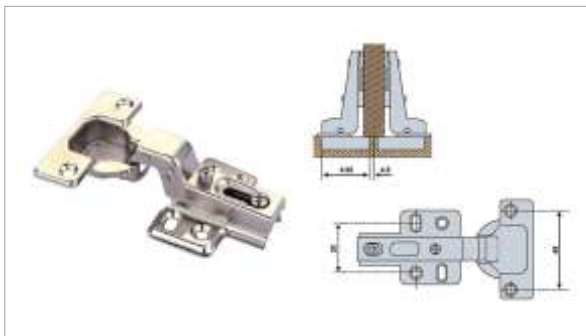

FCH-202C

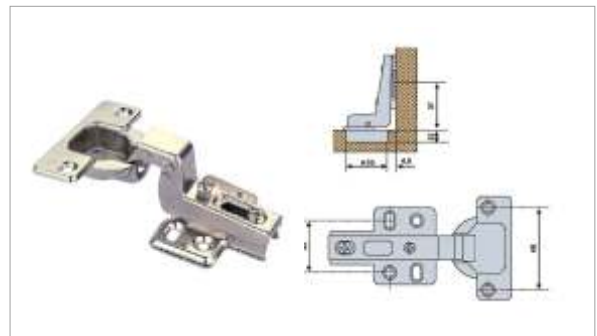

FCH-301A

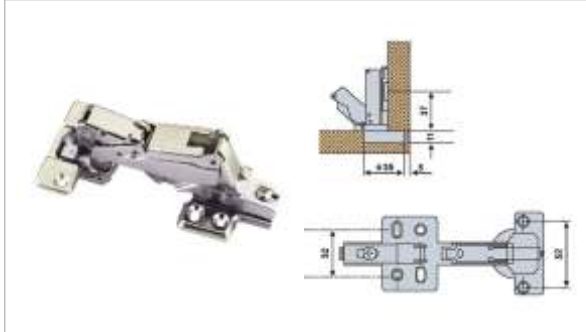

FCH-301B

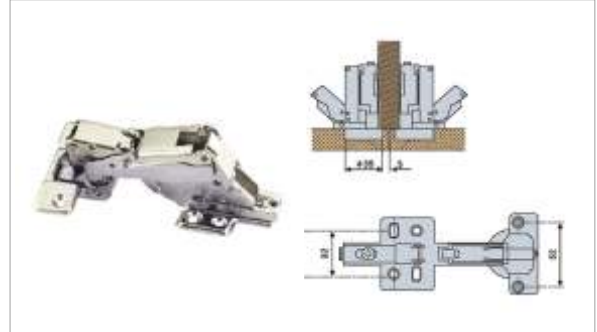

FCH-301C

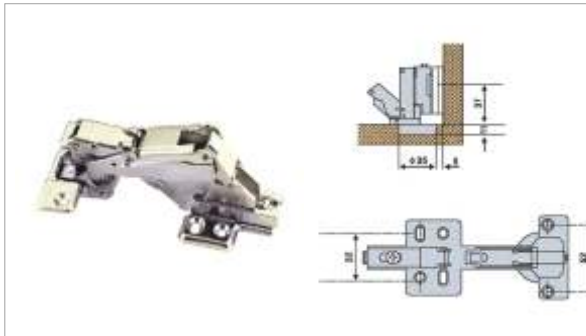

F6000S

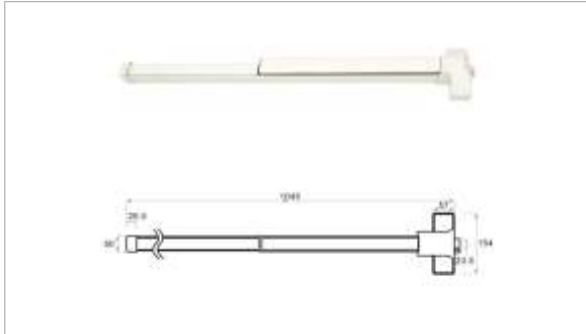

F6000P

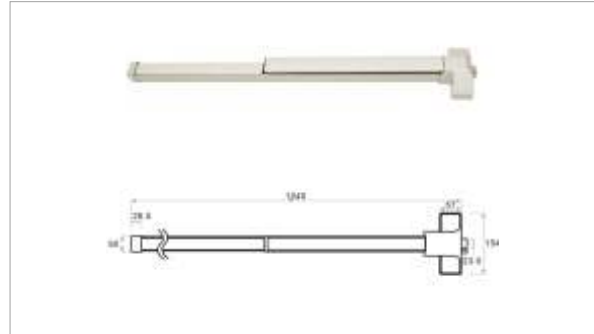

F6000-1S

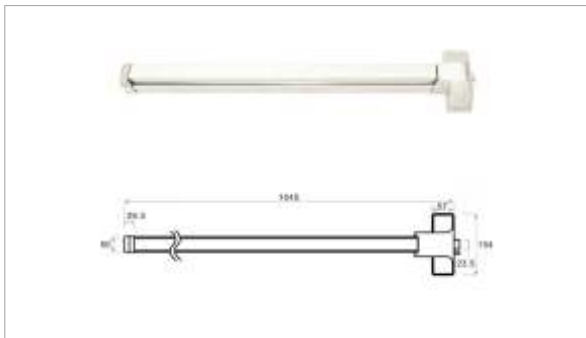

F6000-1P



F6600S/P



F6600-1SP



UL500S

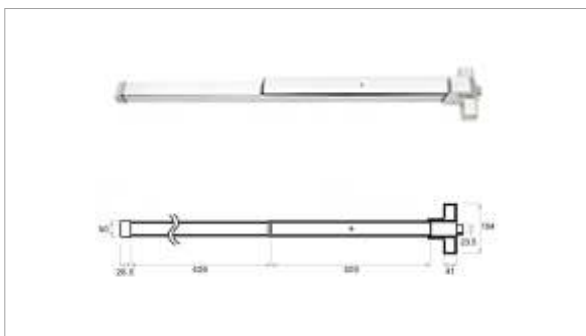

UL500P

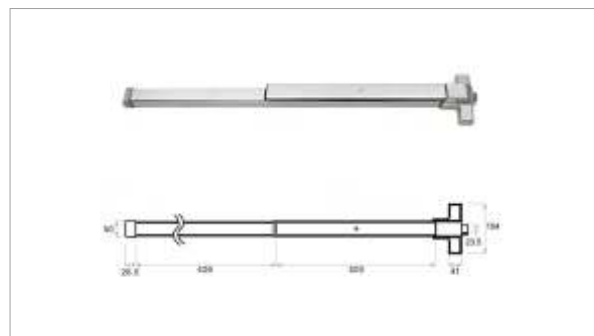

F8000



F8600

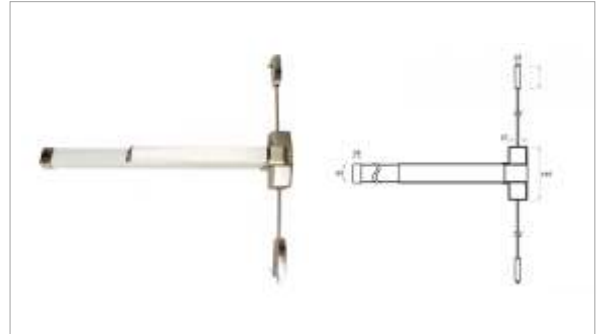

F5000S

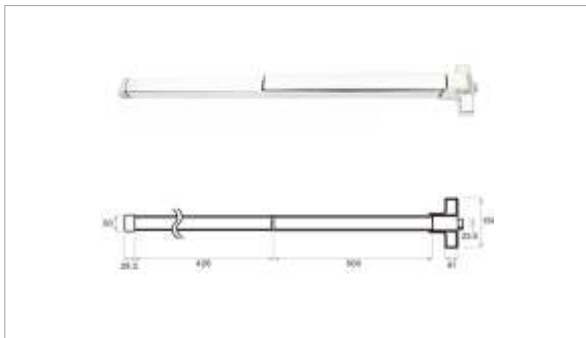

F5000P

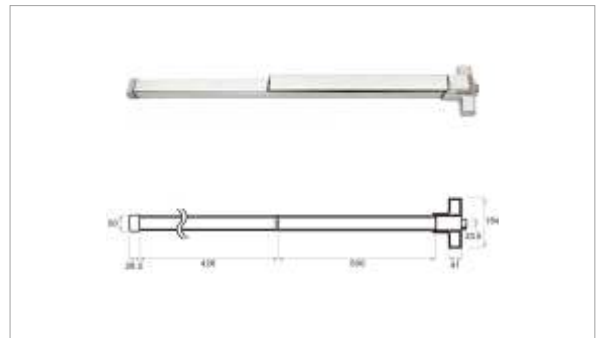

F5000-1S

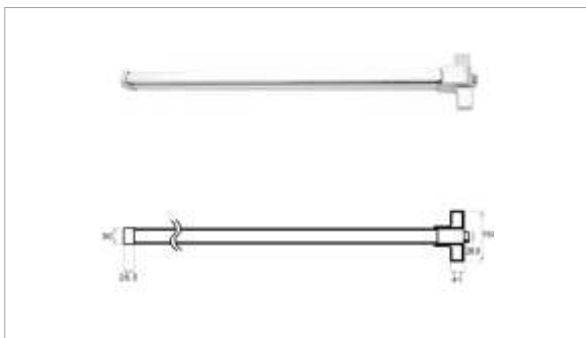

F5000-1P

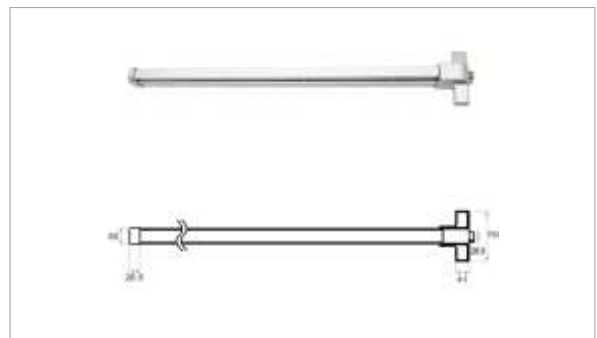

F5600S/P

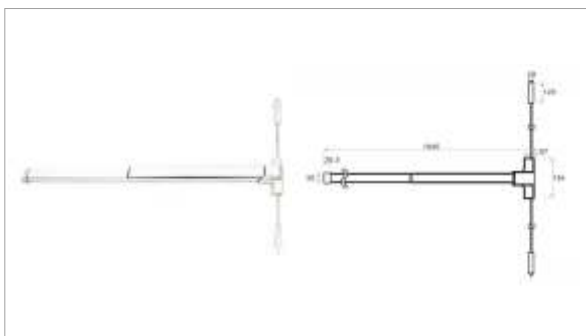

F5600-1SP

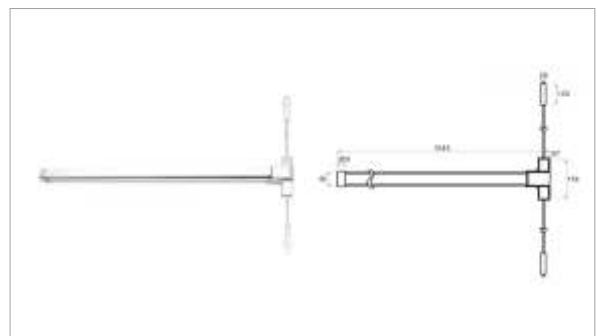

UL500-1S

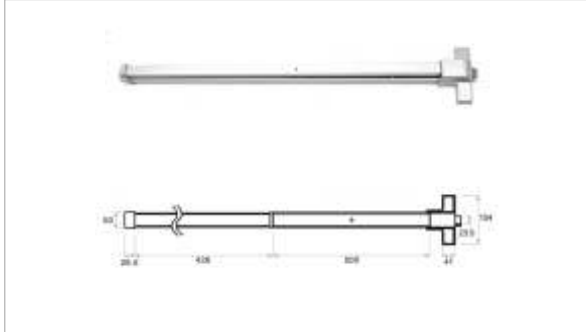

UL500-1P

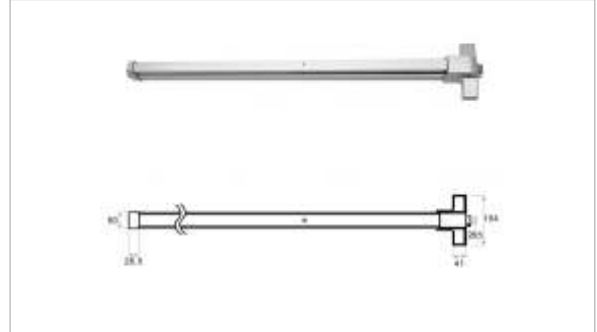

UL560S/P

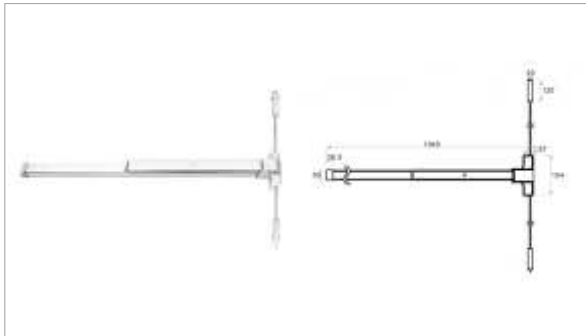

UL560-1S/P

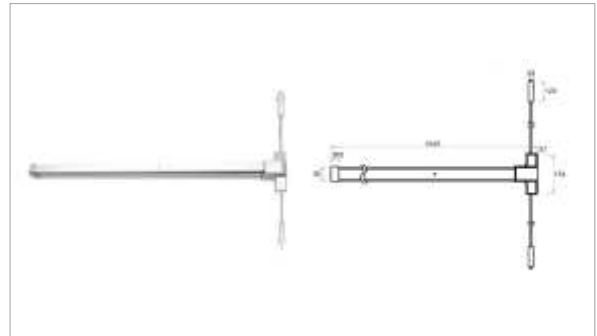

UL600S

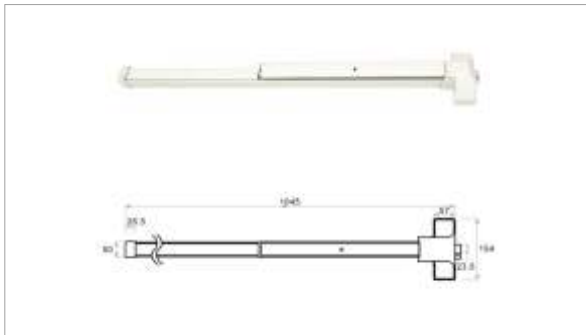

UL600P

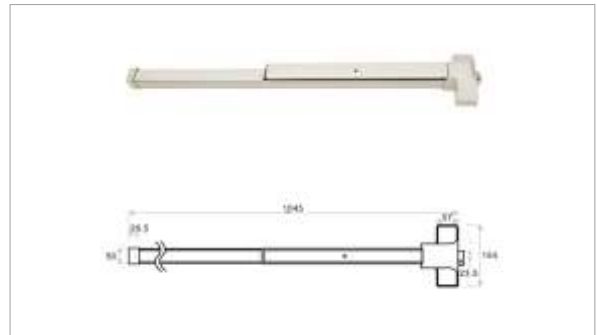

UL600-1S



UL600-1P



UL660S

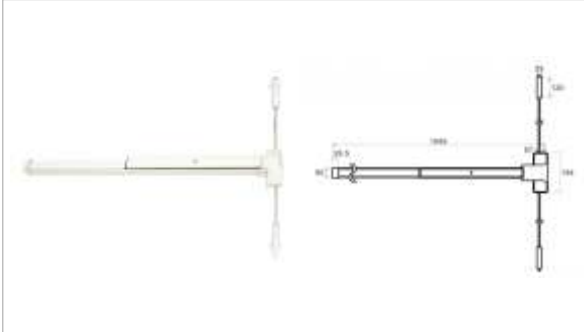

UL660-1S/P



583

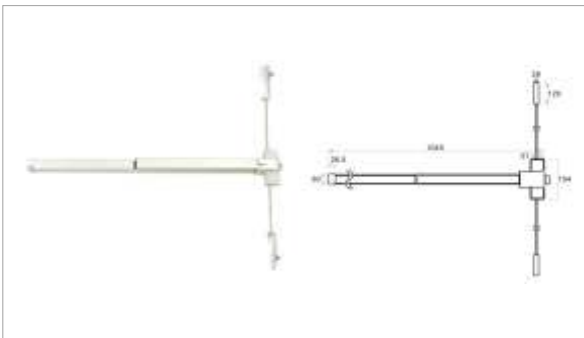

UL510

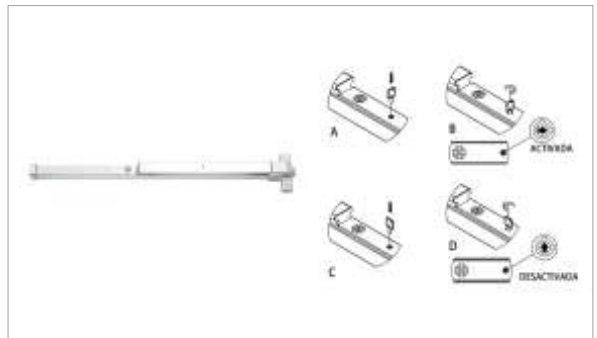

UL551

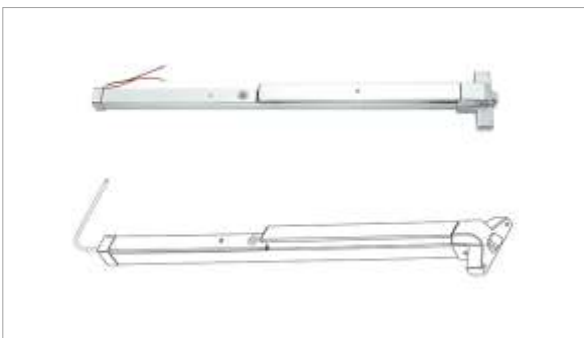

512



F530

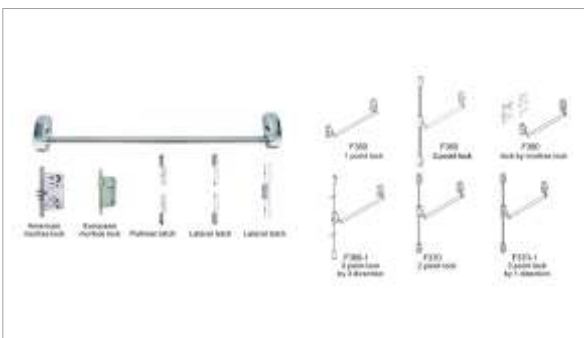

300P

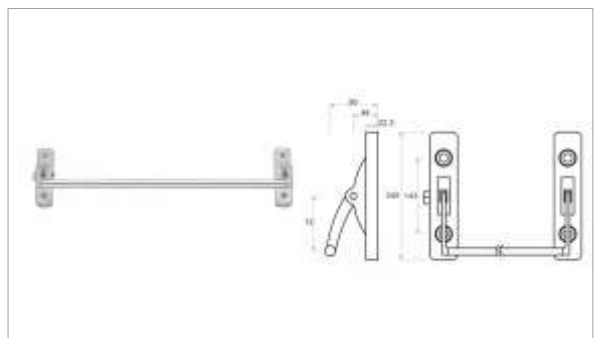

330P-1

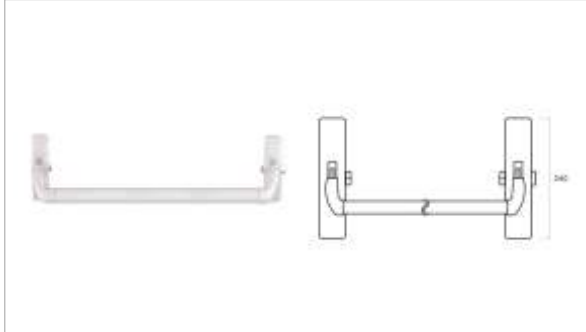

320P

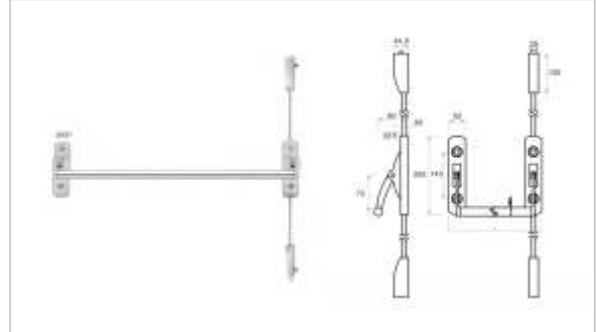

N500

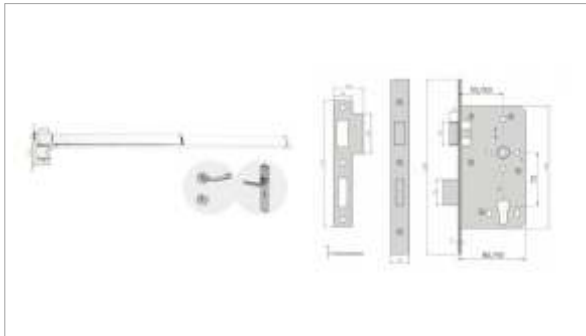

N900

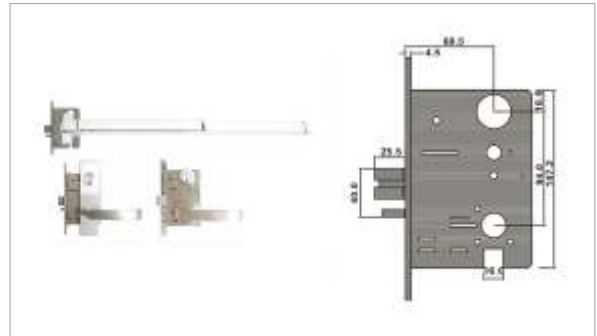

006S-1

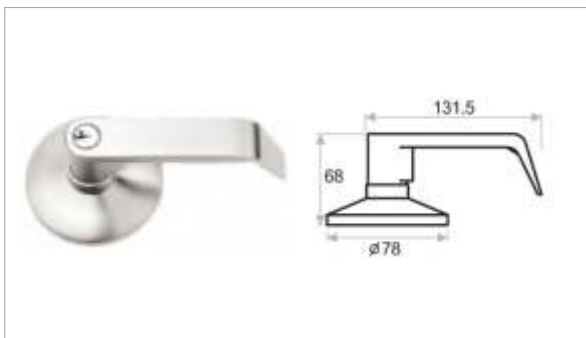

006S-2

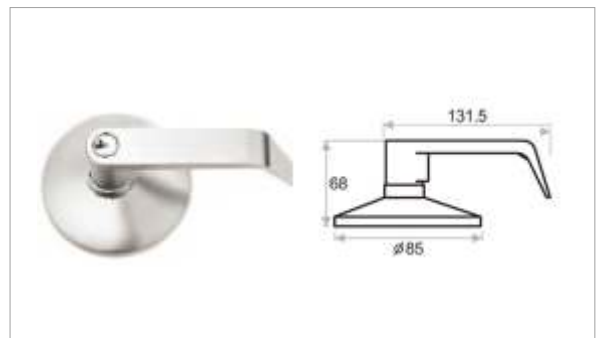

006S-3

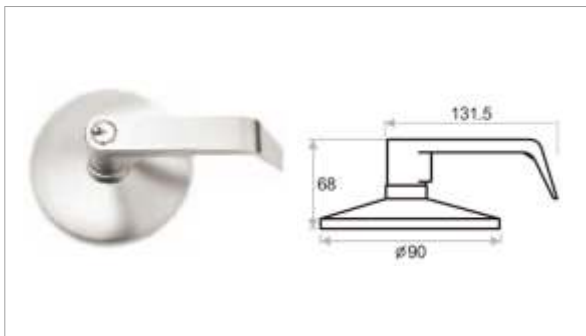

006S



005S

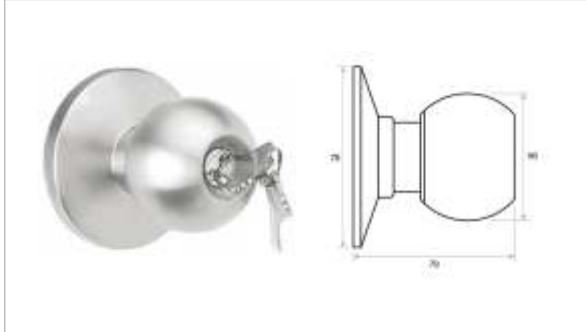

017S/017Z



TO-009



TO-012

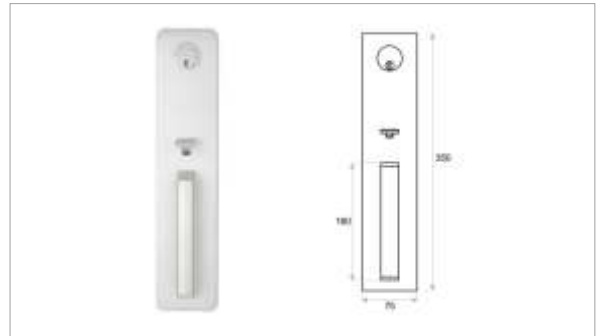

003-1



008



004

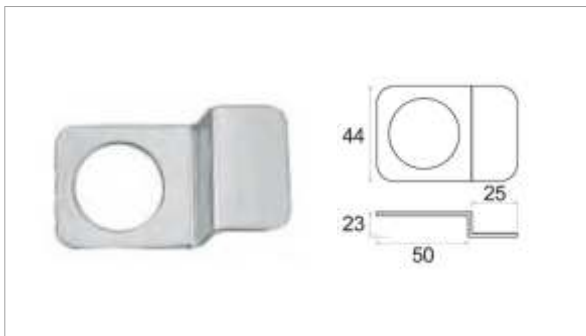

001-1



001

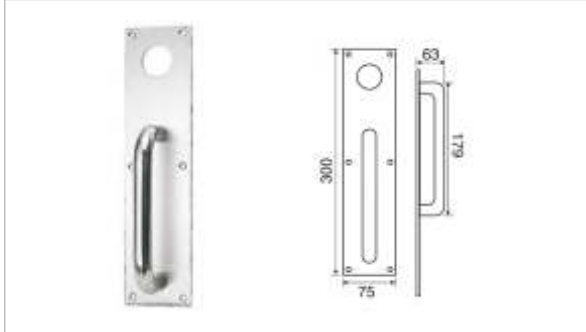

114



TO-910



TO-911



TO-912



1101

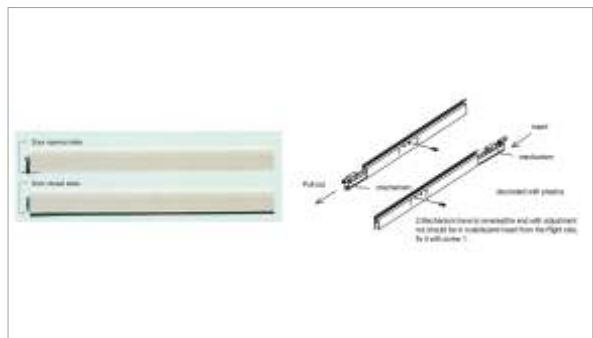

1102

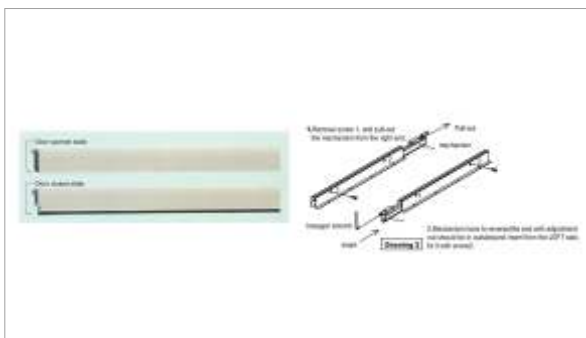

F107-6S



F107-6Q

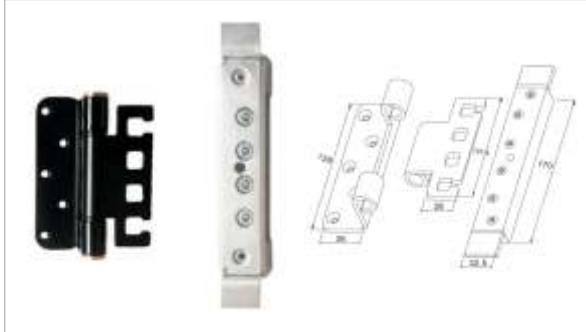

F107-6-ZS

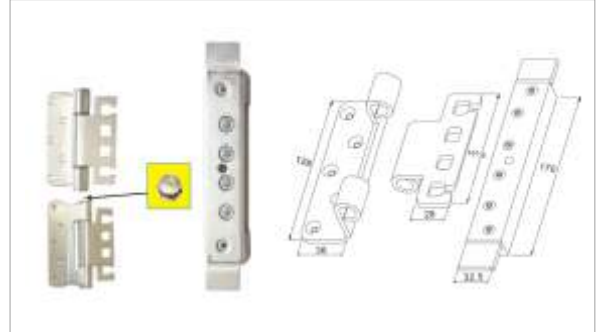

F107-6-ZQ

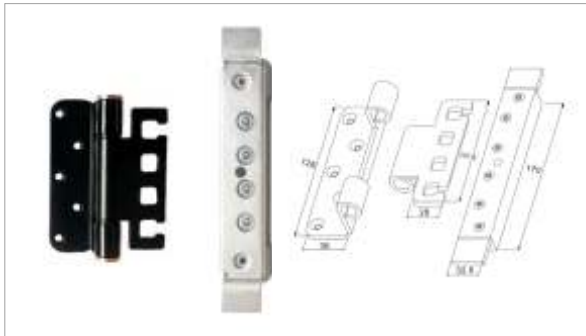

CH001SS



CH002SS



CH003SS

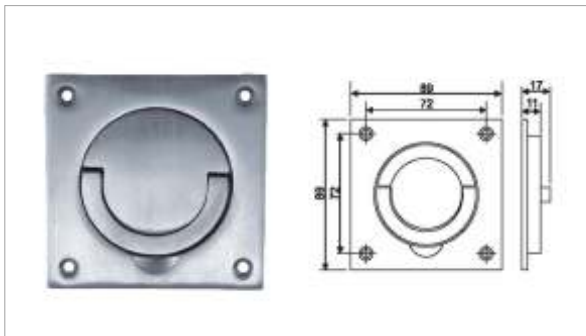

CH004SS

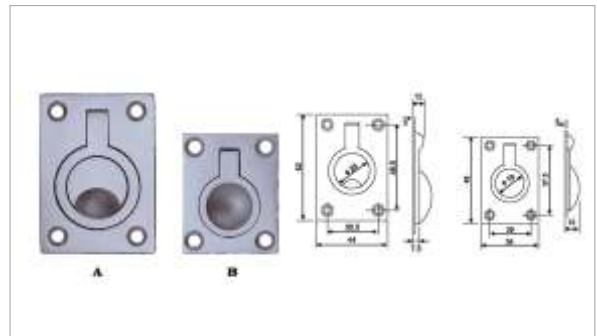

CH005SS



CH006SS

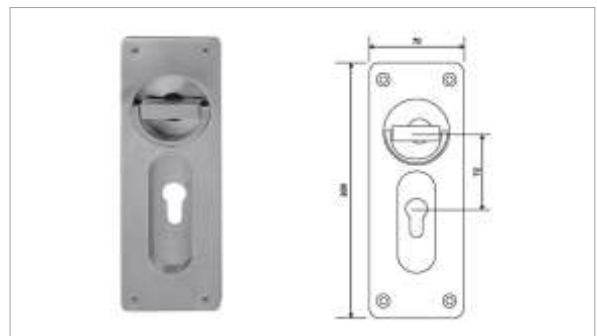

CL-001



CL-002

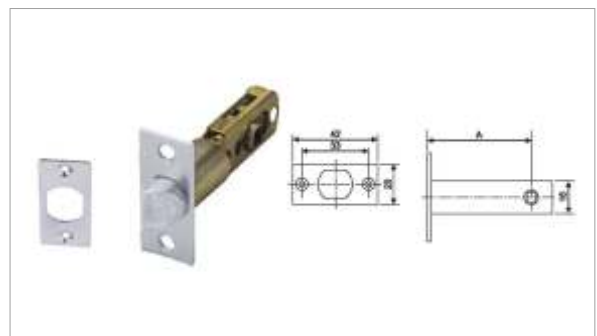

SP001



SP002



SP003



SP005

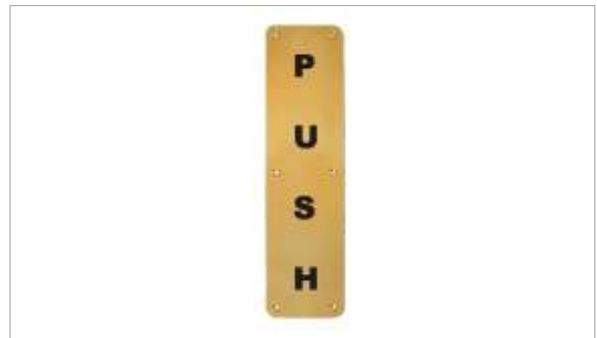

SP006A



SP006B



SP018



SP019



► This page product size can be customized.

SP020



SP021



SP022



SP007



SP008



SP009



SP010



SP011



➤ This page product size can be customized.

SP012



SP013



SP014



SP015



SP016



SP017



SP023



SP024



➤ This page product size can be customized.

IB001SS



IB002SS



IB003SS

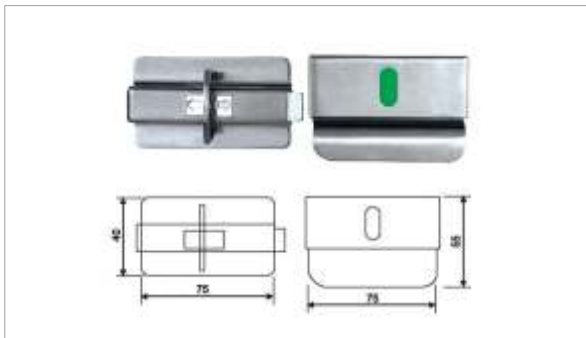

TT001SS

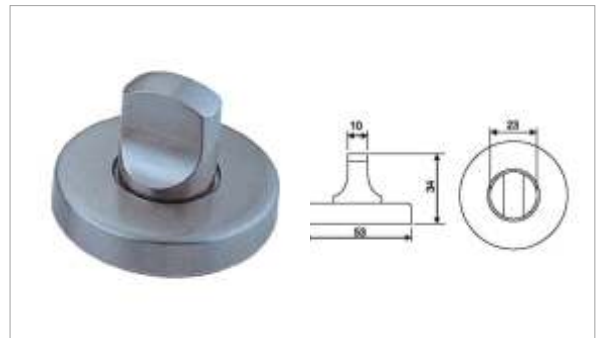

TT002SS

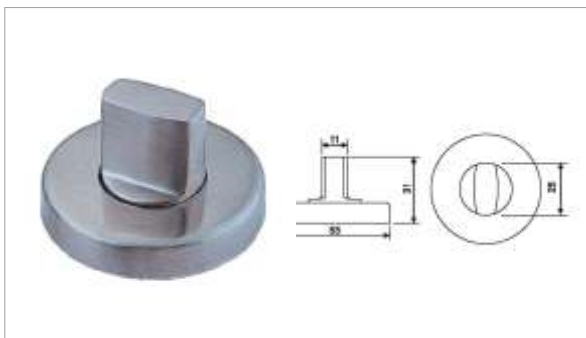

TT003SS

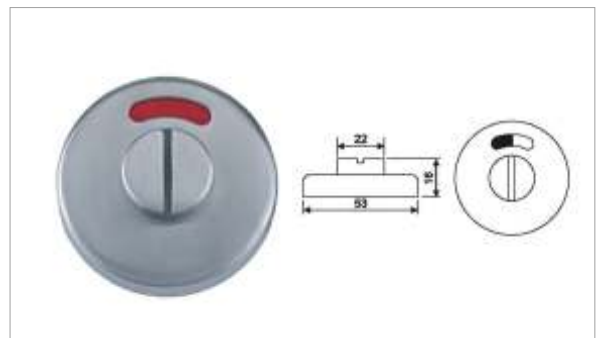

TT004SS

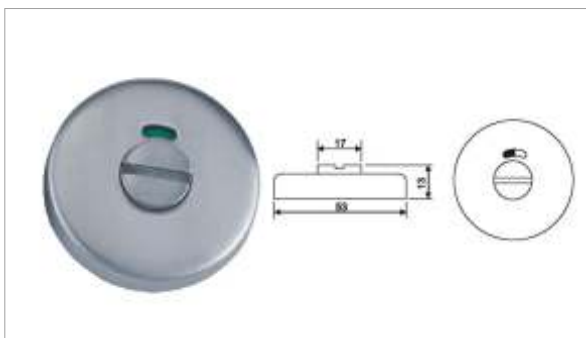

TT005-SS

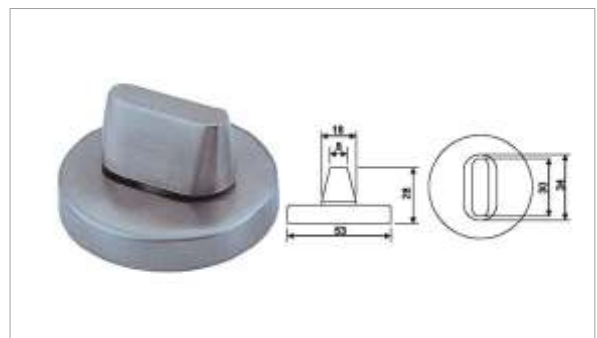

TT006SS



TT007SS

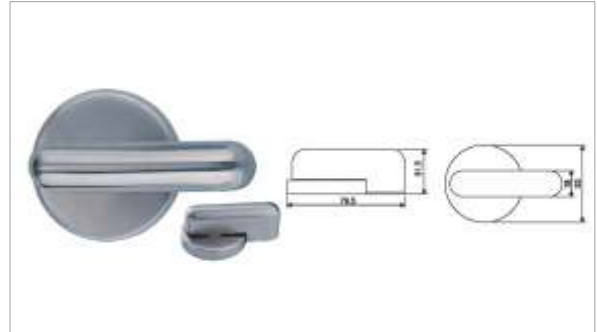

TT008SS-B

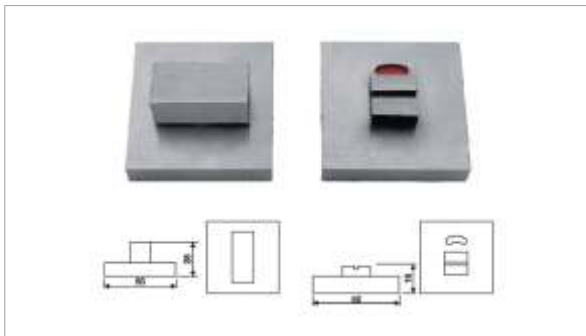

TT009SS

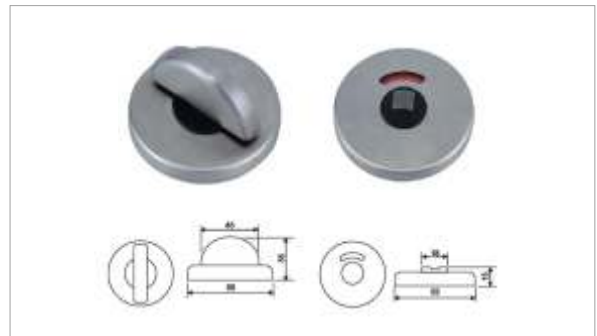

TT008SS-C

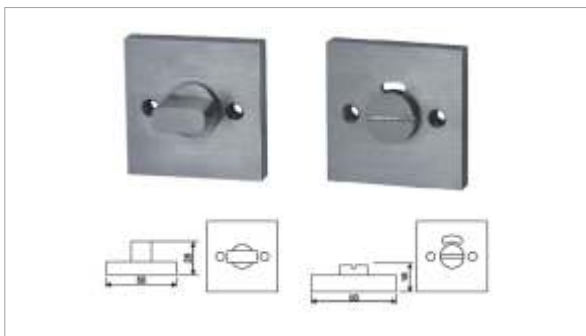

TT010SS

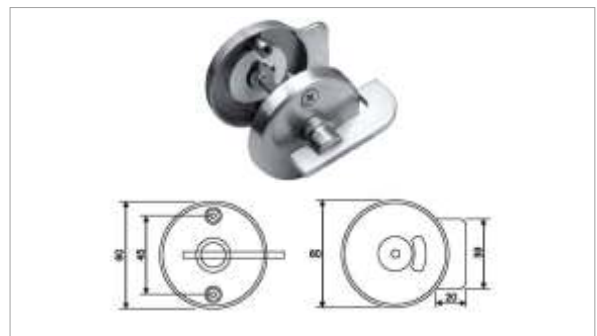

TT011SS

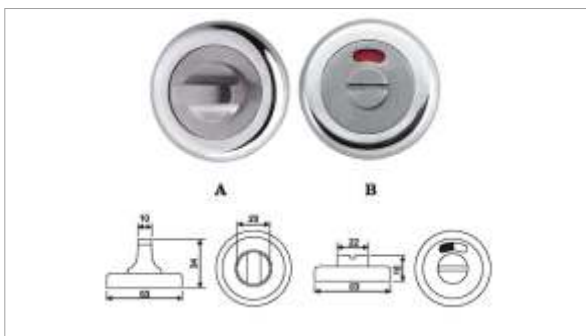

TT012SS

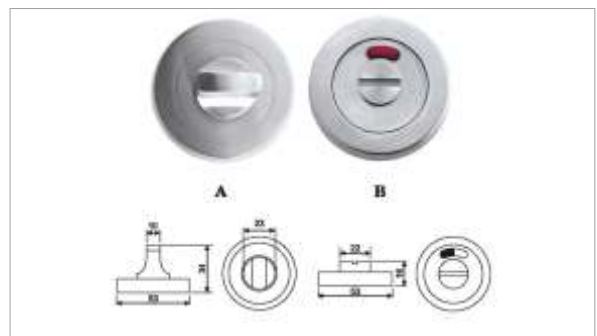

TT013SS



TT014SS



ES001SS

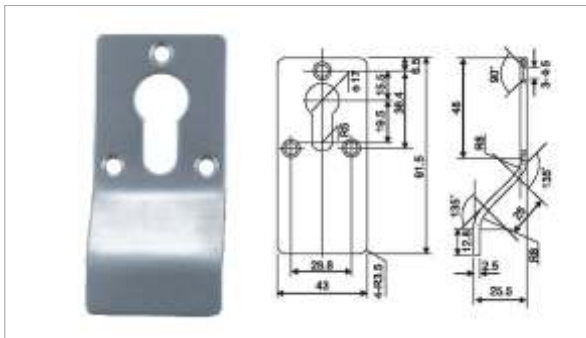

ES003SS

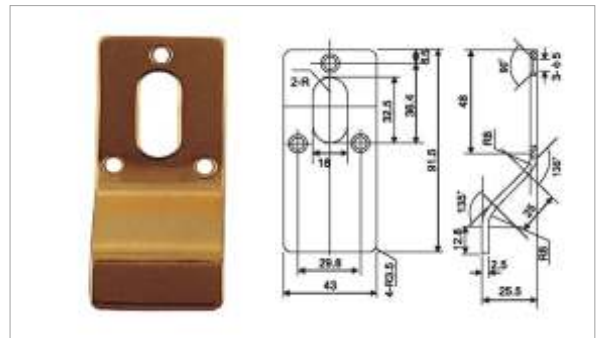

ES002SS

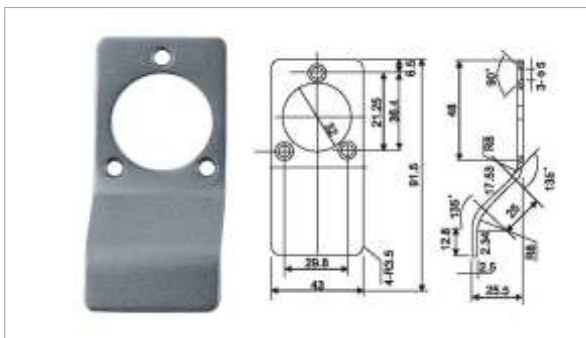

ES004SS

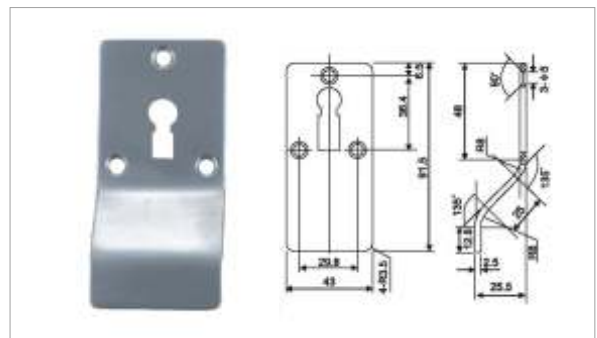

IB004SS

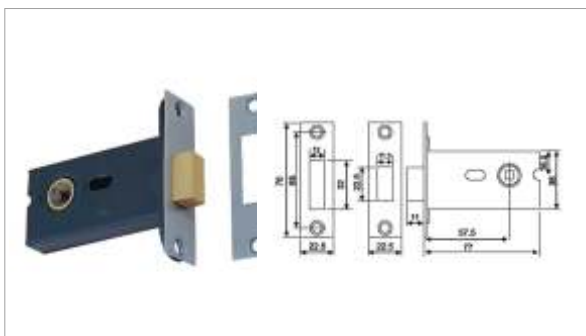

WPF-01



WPF-02

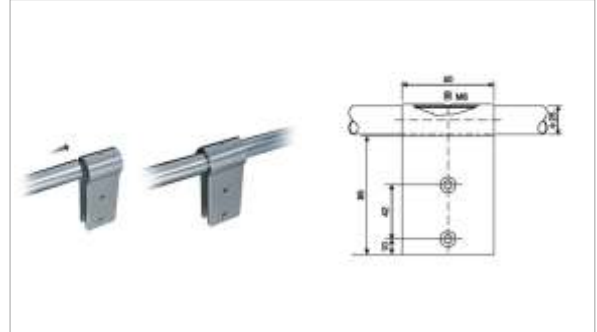

WPF-03



WPF-04

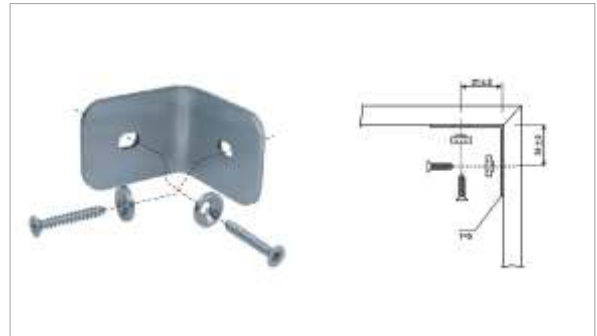

WPF-05a

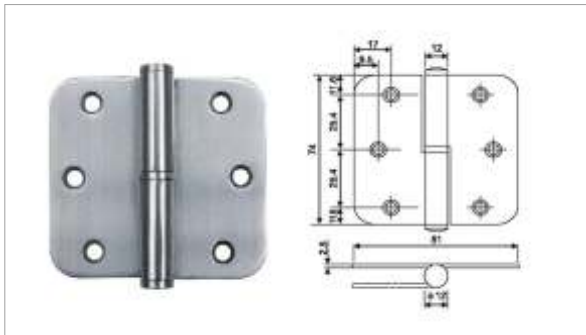

WPF-05b

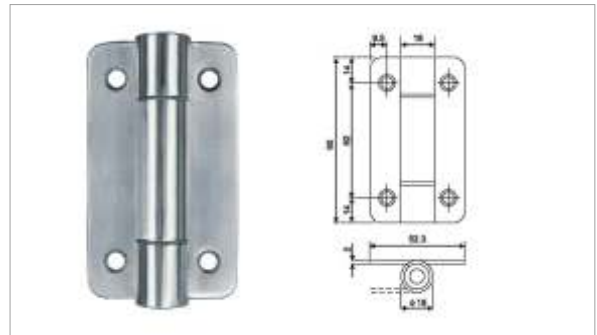

WPF-05c

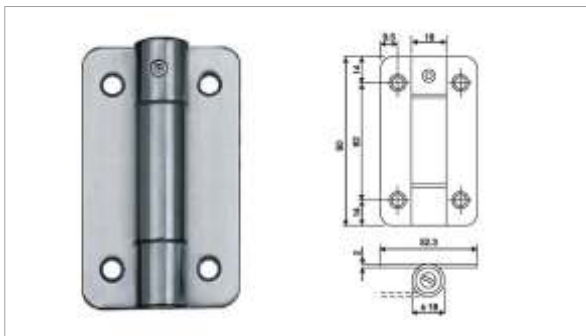

WPF-06a

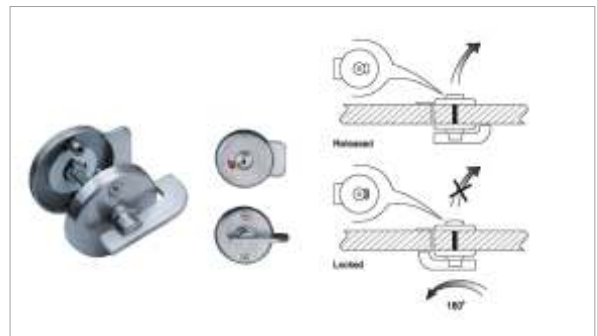

WPF-06b

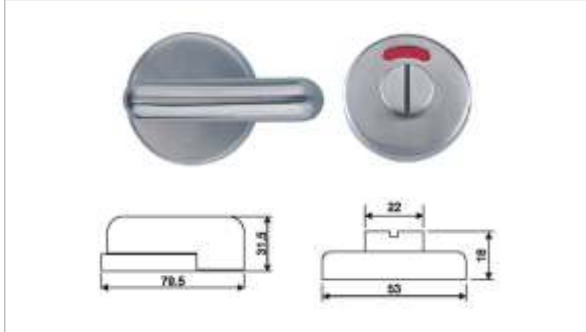

WPF-06c

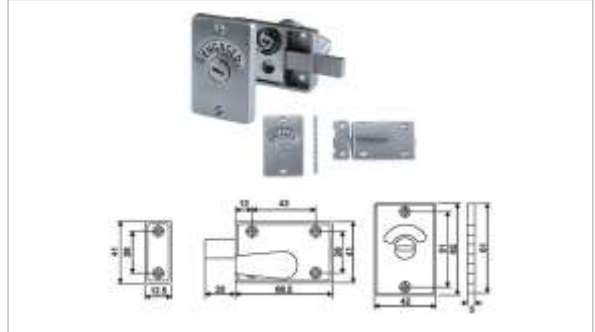

WPF-07

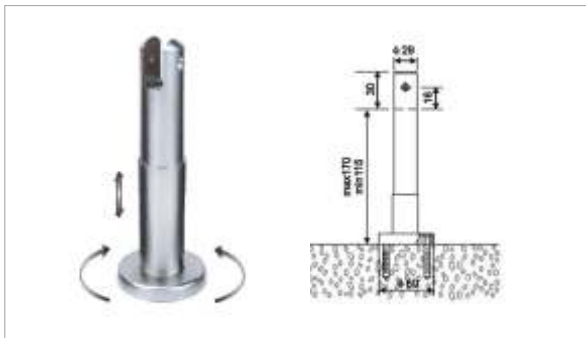

WPF-08

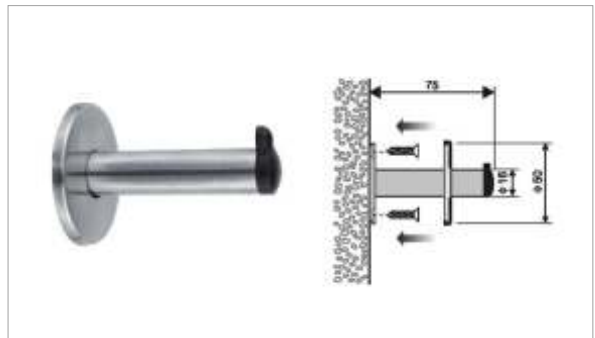

WPF-09a

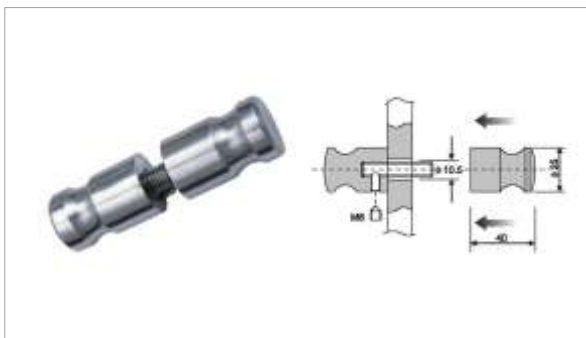

WPF-09b

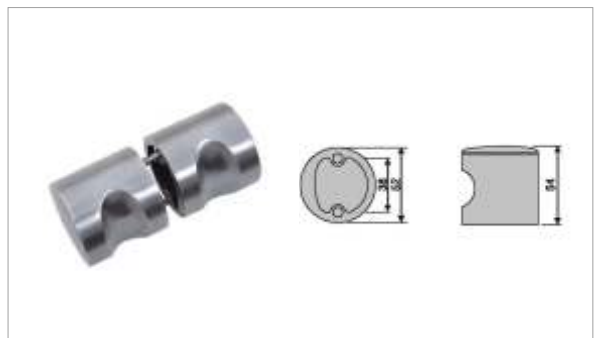

WPF-201

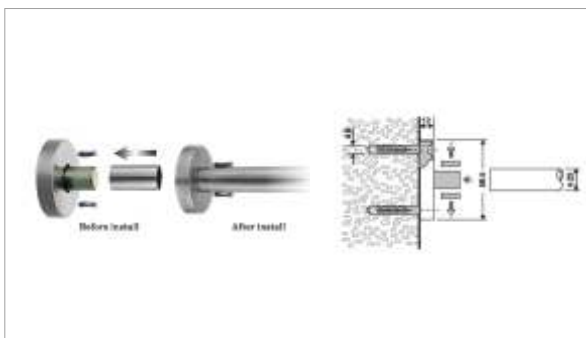

WPF-202

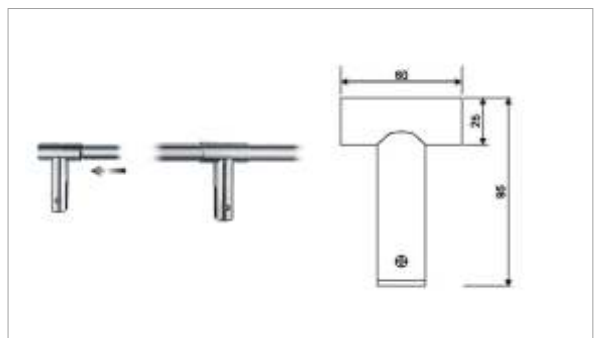

WPF-203



WPF-204

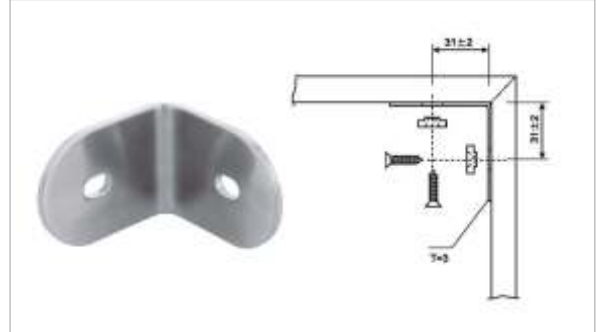

WPF-205a

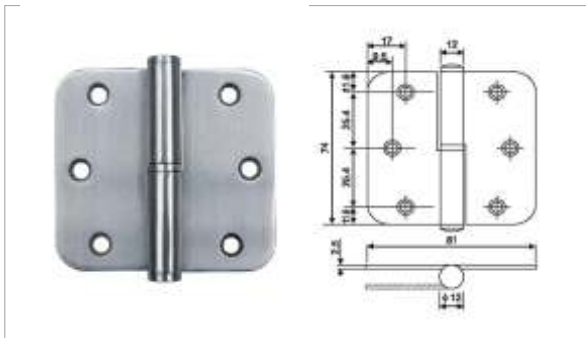

WPF-205b

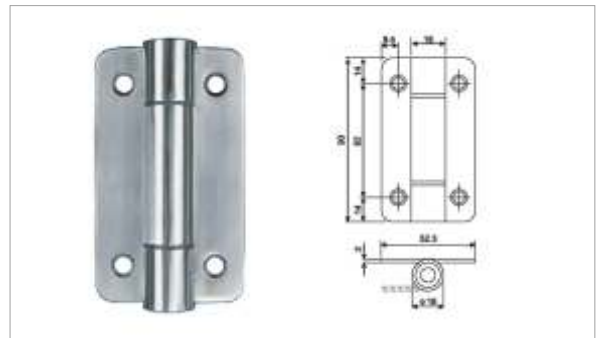

WPF-205c

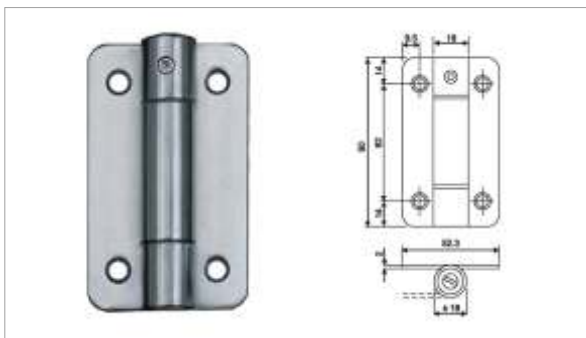

WPF-206

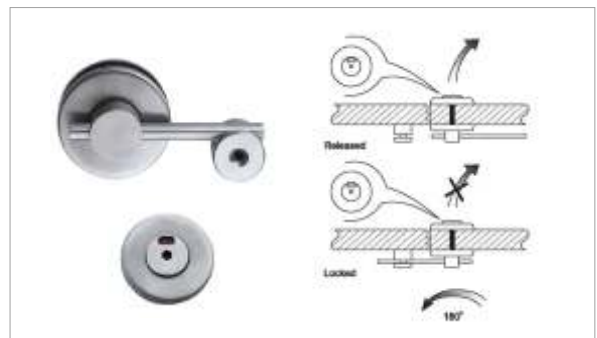

WPF-207



WPF-208

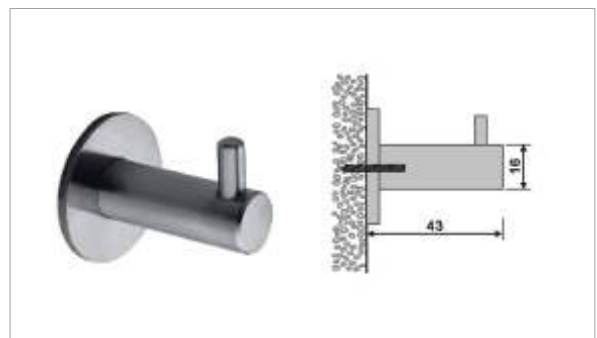

WPF-209



WPF-301



WPF-302

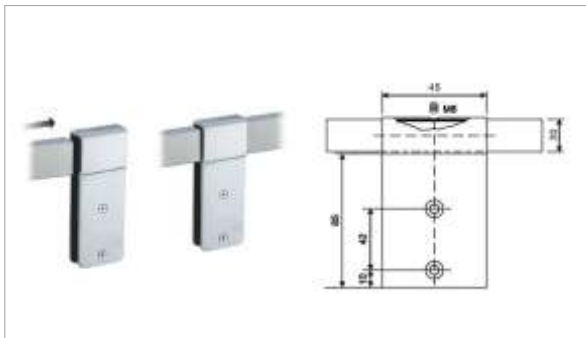

WPF-303

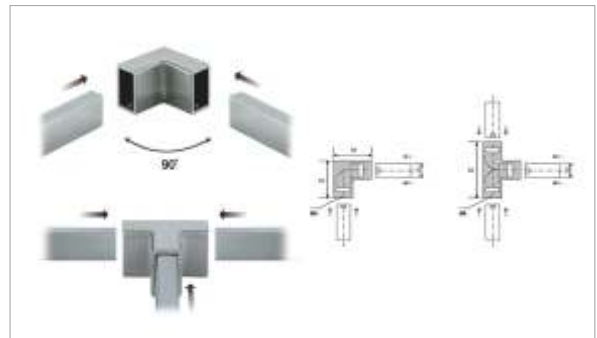

WPF-306

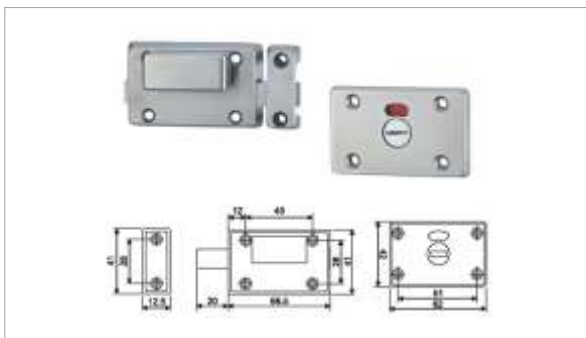

WPF-307



WPF-308

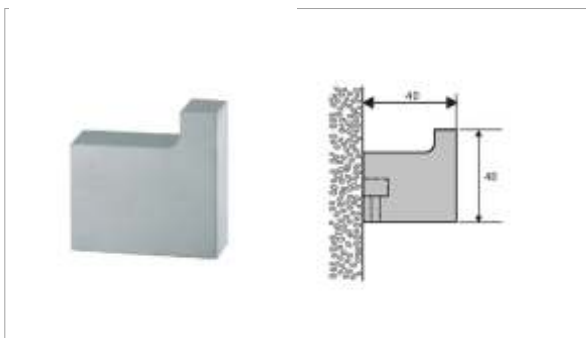

WPF-309

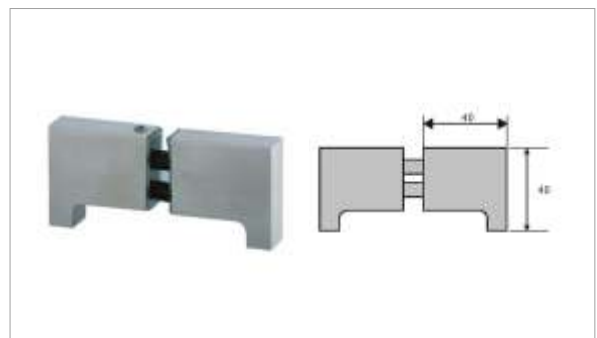

WPF-101



WPF-102

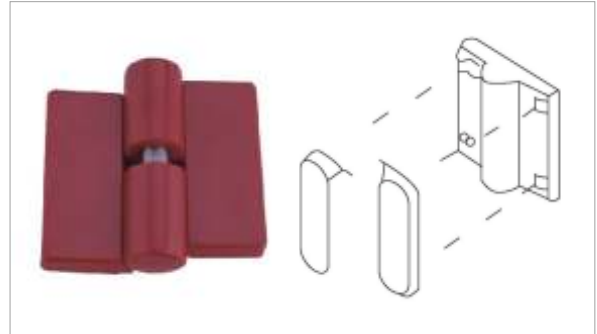

WPF-103

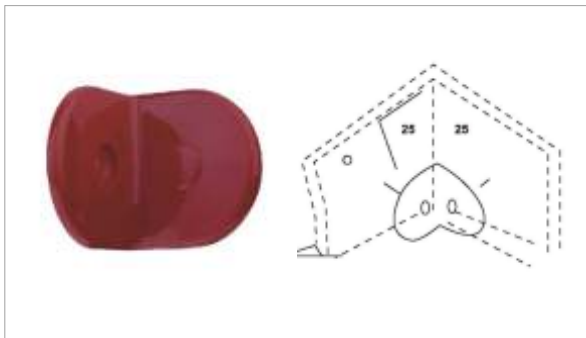

WPF-104

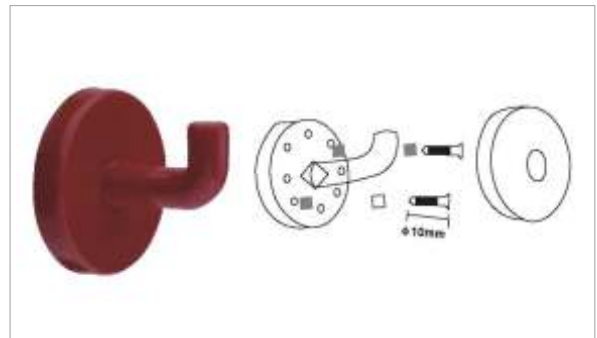

WPF-105



WPF-106

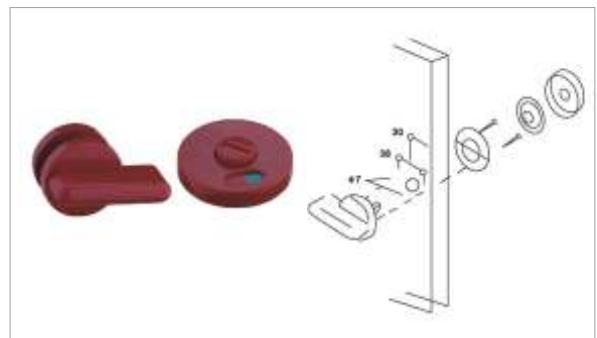

HS-001



HS-002



HS-003

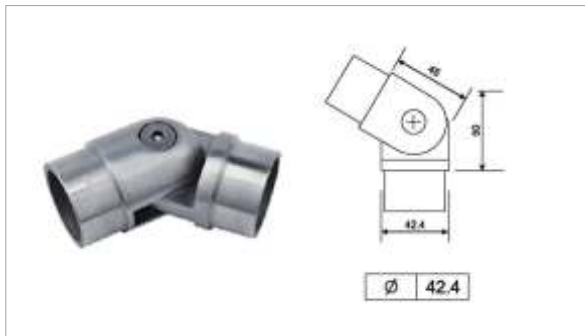

HS-004



HS-005



HS-006



HS-007

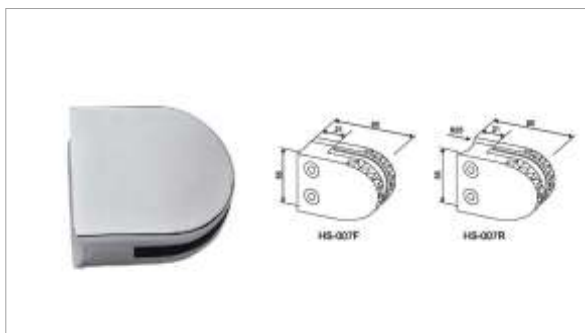

HS-008



HS-009

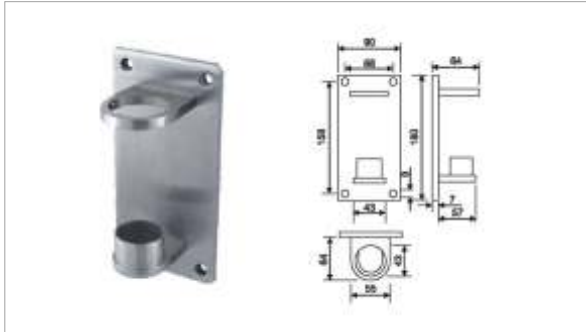

HS-034

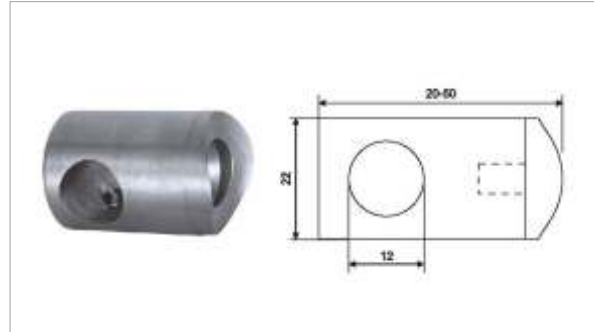

HS-035



HS-036

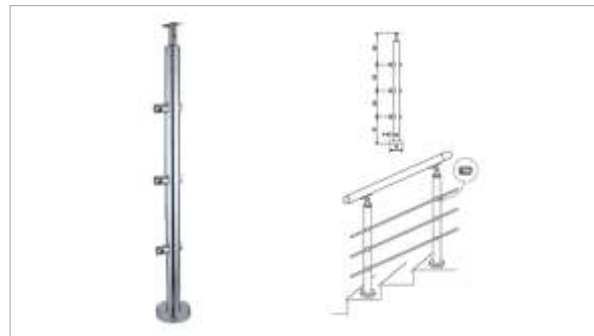

HS-010

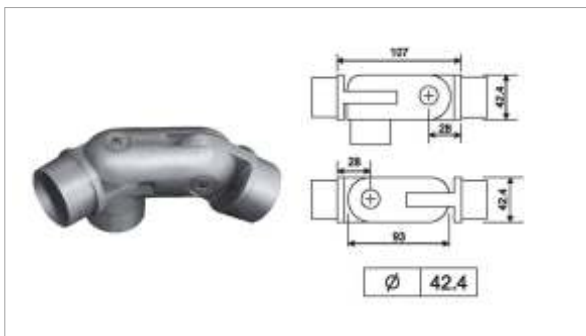

HS-011

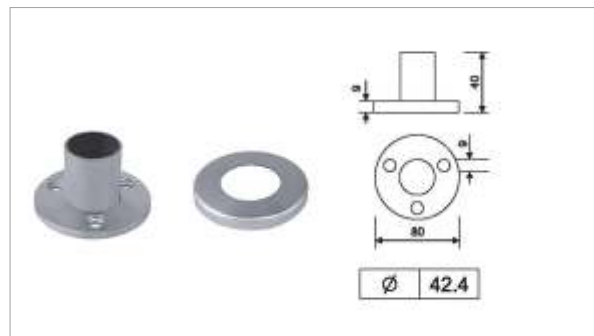

HS-012

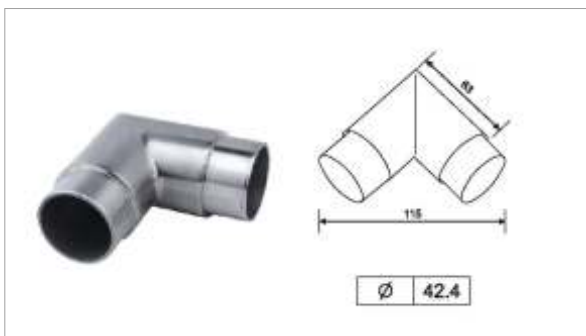

HS-013



HS-014



HS-015

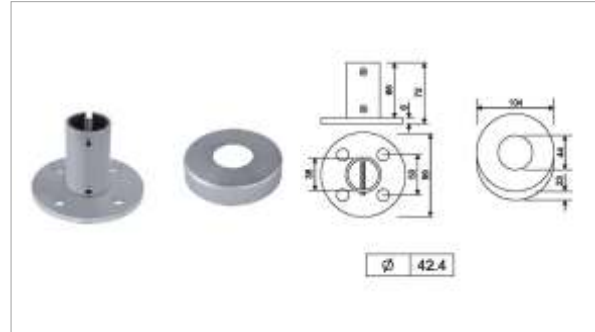

HS-016

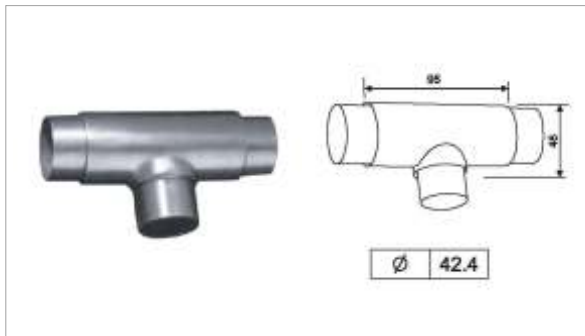

HS-018

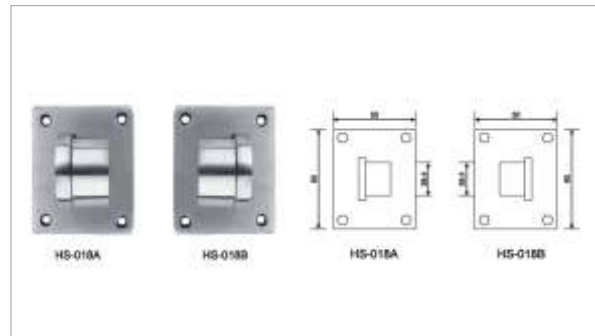

HS-019

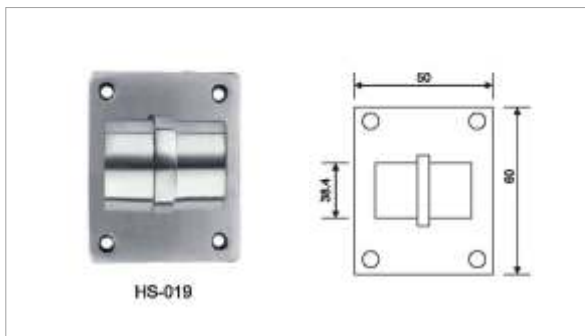

HS-020

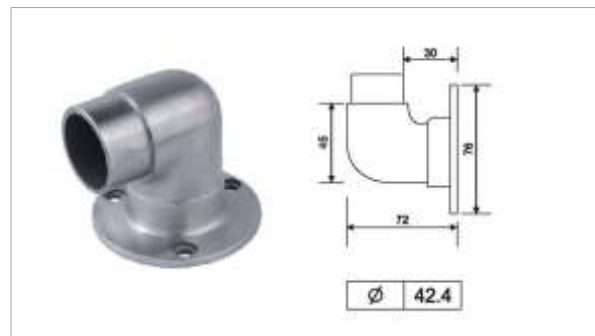

HS-021

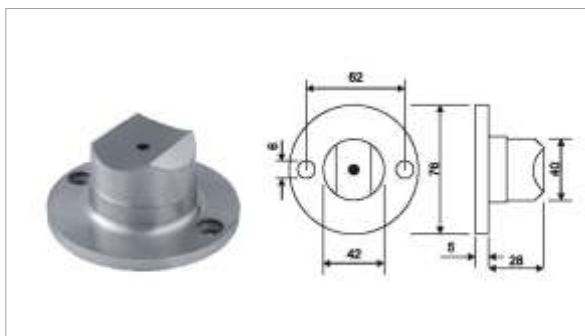

HS-022



HS-023

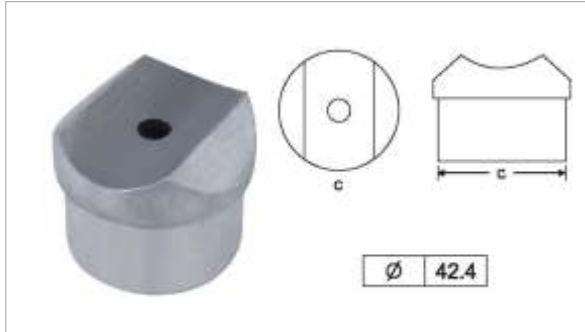

HS-024



HS-025



HS-026

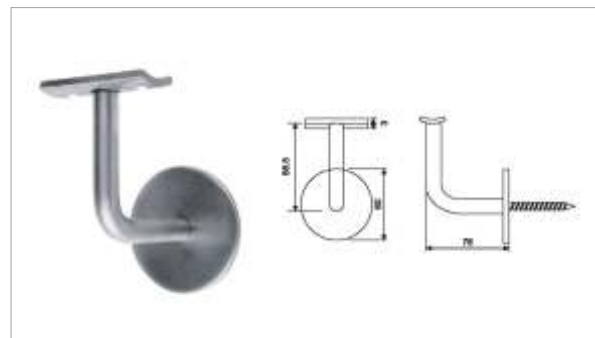

HS-027

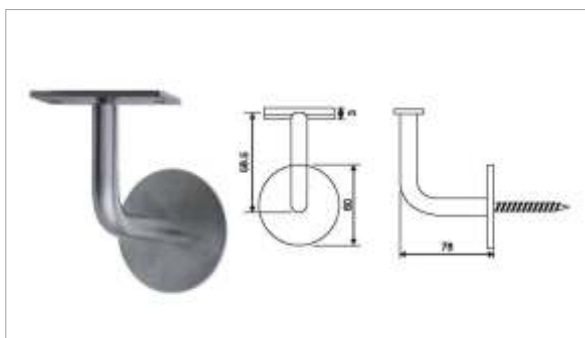

HS-028

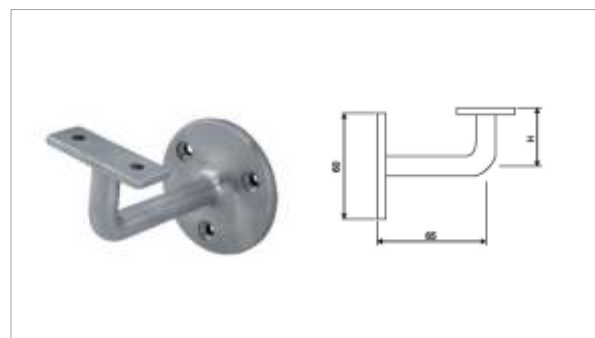

HS-029

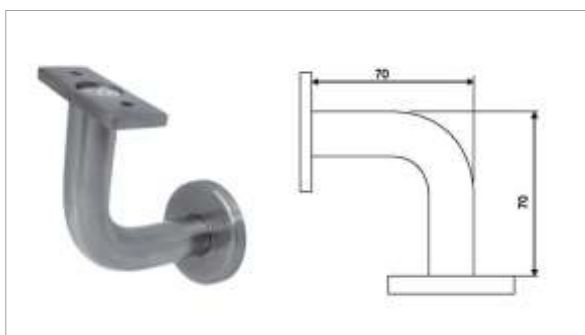

HS-030



HS-031

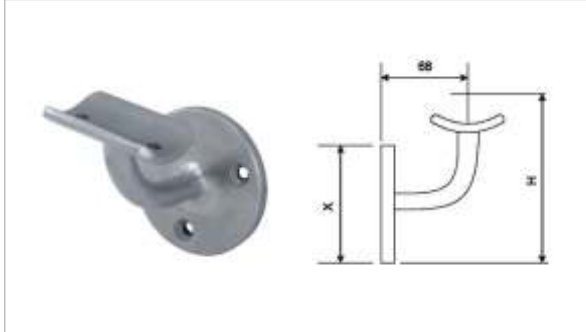

HS-032

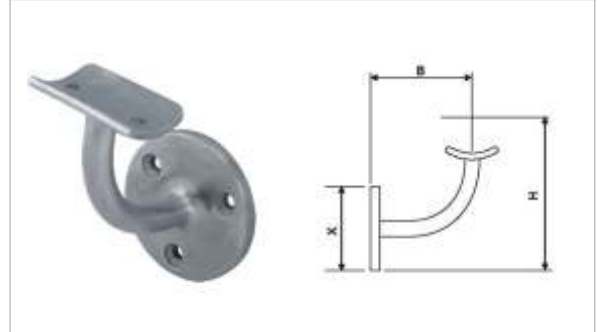

HS-033

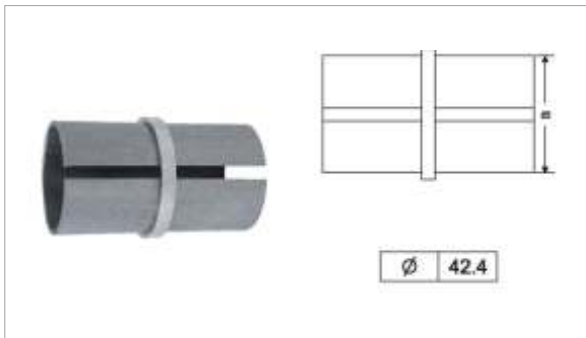

Icon Legends



CE MARKING

CE Marking is a mandatory conformance mark on products placed on the market. With the CE marking on a product, the manufacturer ensures that the product is in conformity with the essential requirements of the applicable Construction Products Directive.



FIRE DOORS HARDWARE

Suitable for use on fire doors.



CERTIFIRE

CERTIFIRE is an independent third party certification scheme that assures performance, quality, reliability and traceability of fire protection products.



HANDICAP

Suitable to meet the needs of disabled people.



BS EN 1906

BS EN1906

BS EN1906 is the British/European standard requirement for lever handles and knob furniture.



BS EN 12209

BS EN12209

BS EN12209 is the British/European standard requirement for locks, latches and locking plates.



BS EN 1303

BS EN1303

BS EN1303 is the British/European standard requirement for cylinders for locks.



BS EN 1935

BS EN1935

BS EN1935 is the British/European standard requirement for single axis hinges.



BS EN 1154

BS EN1154

BS EN1154 is the British/European standard requirement for controlled door closing devices.



BS EN 1125

BS EN1125

BS EN1125 is the British/European standard requirement for panic exit devices operated by a horizontal bar



ISO 9001:2008

ISO 9001:2008 Registered Company



10 Year Mechanical Guarantee



5 Year Mechanical Guarantee

➤ CERT certification



➤ UL CERTIFICATION certification

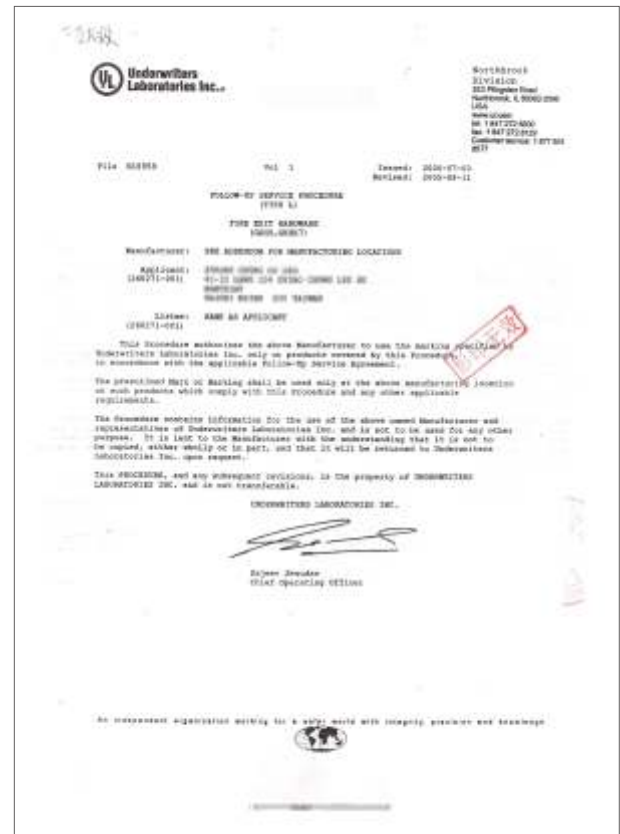

➤ 3H UL-F certification



➤ Fire Resistance test report-lever handle



Certification

▶ Test verification of conformity-lever handle

intertek
Test Quality. Intertek.

Intertek Legal Entity and address
UK/Ver

Test Verification of Conformity

In the light of the tests undertaken, the sample(s) of the below product have been found to comply with the requirements of the referenced specifications at the time the tests were carried out.

Applicant Name & Address: JINCHENG Hardware Industry Co., Ltd
No.191, Wuxiang Industrial Development Zone, Lili Town, Jiangshi District, Jiangmen City, Guangdong Province, China

Product Description, Range & Principle Characteristics: Lever handle

Model: JTH100, JTH102, JTH104, JH104, JH104A, JH104B, JH104C, JH104D, JH104E, JH104F, JH104G, JH104H, JH104I, JH104J, JH104K, JH104L, JH104M, JH104N, JH104O, JH104P, JH104Q, JH104R, JH104S, JH104T, JH104U, JH104V, JH104W, JH104X, JH104Y, JH104Z

Relevant Standards: GB 2006-2012 Building Hardware - Lever handles and knob furniture - Requirements and test methods

Verification Testing Office: Same as legal entity

Date of Tests: March 2, 2017 to March 21, 2017

Test Report Number(s): ETR002020201-000 & 100100020201-001

This verification is part of the full test report(s) and should be read in conjunction with them.
Fire resistance time: 320 Minutes

Cindy Chan
Signature

Name: Cindy Chan
Position: Supervisor
Date: April 10, 2017

The facilities at the test site used in the above tests are certified in accordance with the requirements of the relevant standards and are fully compliant with the requirements of the relevant standards. The test results, however, do not constitute a guarantee of the quality of the product. The test results are only valid for the specific product and test methods used in the above tests. The test results are only valid for the specific product and test methods used in the above tests. The test results are only valid for the specific product and test methods used in the above tests.

www.intertek.com Page 1 of 2 QP-CP-11-07-March 2017

▶ EN1906 test report-lever handle

Intertek

TEST REPORT

EN 1906
Building hardware -
Lever handles and knob furniture - Requirements and test methods

Report reference No.: 175000336021401

Tested by (name and signature): Nelson Zhu *Nelson Zhu*
Engineer

Approved by (name and signature): Cindy Chan *Cindy Chan*
Supervisor

Date of issue: April 14, 2017

Contents: Total test report: 13 pages including
Report text: 1 page
Appendix A for product photo: 4 pages
Appendix B for document register: 1 page
Revision Page: 1 page

Testing Laboratory name: Intertek Testing Services Shenzhen Ltd, Guangzhou Branch
Address: No. 9 Nan Xiang Sea Road, OCTCO, Guangzhou, China 510632

Testing location: Same as above

Applicant's name: JINCHENG Hardware Industry Co., Ltd
Address: No.191 Wuxiang Industrial Development Zone, Lili Town, Jiangshi District, Jiangmen City, Guangdong Province, China

Test specification:
Standard: EN 1906:2012
Non-standard test method: N/A
Test Report Form No.: TTRF EN 1906:2012 B
TTRF Originator: Intertek Testing Services Shenzhen Ltd, Guangzhou Branch
Master TTRF: [Redacted]

Test item description: Lever Handle

TradeMark: Jincheng

Model and/or type reference: JTH100, JTH102, JTH104, JH104, JH104A, JH104B, JH104C, JH104D, JH104E, JH104F, JH104G, JH104H, JH104I, JH104J, JH104K, JH104L, JH104M, JH104N, JH104O, JH104P, JH104Q, JH104R, JH104S, JH104T, JH104U, JH104V, JH104W, JH104X, JH104Y, JH104Z

Manufacturer: JINCHENG Hardware Industry Co., Ltd

Rating: 4 7 - - 0 3 0 0

Summary of testing:
The submitted samples COMPLIED with all applicable clauses of EN 1906:2012 for the classification.

TTRF EN 1906:2012 B
Originator: Intertek Testing Services Shenzhen Ltd, Guangzhou Branch
Intertek copyright indicator: 10-2015 Intertek

▶ door closer CE report - 505

Certificate of Constancy of Performance
0359-CPR-000539

Intertek

In compliance with Regulation 305/2011/EU of the European Parliament and of the Council of 8 March 2011 (the Construction Products Regulation), this certificate applies to the construction product(s).

Product(s): Controlled door closing devices (refer to attached appendix for details and conditions)

Placed on the market under the trade mark of: Foshan Baywin Security Technology Co., Ltd, No.8 East of 2 Road Xijiao Industrial North Zone Beijiao Town Shunde District Foshan City Guangdong Province, 528311 China

Produced in the manufacturing plant(s): Foshan Baywin Security Technology Co., Ltd, No.8 East of 2 Road Xijiao Industrial North Zone Beijiao Town Shunde District Foshan City Guangdong Province, 528311 China

Intended use: On fire and smoke compartmentation doors to fulfil the self-closing requirement of such doors.

This certificate attests that all provisions concerning the assessment and verification of constancy of performance described in Annex ZA of the standard(s):
EN 1154:1996/A1:2002/AC:2008

Under system 1 for the performance set out in this certificate are applied and that the performance of the construction product is assessed to remain constant.

This certificate was first issued on 30th March 2017 under CPR (305/2011) and will remain valid as long as neither the harmonised standard, the construction product, the AACP methods nor the manufacturing conditions in the plant are modified significantly, unless suspended or withdrawn by the notified product certification body.

The issued document and statement(s) herein makes reference only to a presumption of conformity in accordance with the CPR Regulation (EU 305/2011) (as amended). However, it is the manufacturer's or their authorised representative's sole responsibility to affix the CE logo and, by doing so, confirm full compliance and conformity to all other European regulatory directives and regulations that may also apply.

CE
0359

intertek Testing & Certification Limited
Cloppa Road, Lathford
Dunfermline, Fife, KY12 2JG
Tel: +44 (0)1752 311000
Fax: +44 (0)1752 311077
E-mail: info@intertek.com
www.intertek.com

intertek Testing & Certification Limited
Cloppa Road, Lathford
Dunfermline, Fife, KY12 2JG
Tel: +44 (0)1752 311000
Fax: +44 (0)1752 311077
E-mail: info@intertek.com
www.intertek.com

intertek Testing & Certification Limited
Cloppa Road, Lathford
Dunfermline, Fife, KY12 2JG
Tel: +44 (0)1752 311000
Fax: +44 (0)1752 311077
E-mail: info@intertek.com
www.intertek.com

The facilities at the test site used in the above tests are certified in accordance with the requirements of the relevant standards and are fully compliant with the requirements of the relevant standards. The test results, however, do not constitute a guarantee of the quality of the product. The test results are only valid for the specific product and test methods used in the above tests. The test results are only valid for the specific product and test methods used in the above tests. The test results are only valid for the specific product and test methods used in the above tests.

Page 1 of 2

▶ door closer CE report - 068

Certificate of Constancy of Performance
0359-CPR-000540

Intertek

In compliance with Regulation 305/2011/EU of the European Parliament and of the Council of 8 March 2011 (the Construction Products Regulation), this certificate applies to the construction product(s).

Product(s): Controlled door closing devices (refer to attached appendix for details and conditions)

Placed on the market under the trade mark of: Foshan Baywin Security Technology Co., Ltd, No.8 East of 2 Road Xijiao Industrial North Zone Beijiao Town Shunde District Foshan City Guangdong Province, 528311 China

Produced in the manufacturing plant(s): Foshan Baywin Security Technology Co., Ltd, No.8 East of 2 Road Xijiao Industrial North Zone Beijiao Town Shunde District Foshan City Guangdong Province, 528311 China

Intended use: On fire and smoke compartmentation doors to fulfil the self-closing requirement of such doors.

This certificate attests that all provisions concerning the assessment and verification of constancy of performance described in Annex ZA of the standard(s):
EN 1154:1996/A1:2002/AC:2008

Under system 1 for the performance set out in this certificate are applied and that the performance of the construction product is assessed to remain constant.

This certificate was first issued on 30th March 2017 under CPR (305/2011) and will remain valid as long as neither the harmonised standard, the construction product, the AACP methods nor the manufacturing conditions in the plant are modified significantly, unless suspended or withdrawn by the notified product certification body.

The issued document and statement(s) herein makes reference only to a presumption of conformity in accordance with the CPR Regulation (EU 305/2011) (as amended). However, it is the manufacturer's or their authorised representative's sole responsibility to affix the CE logo and, by doing so, confirm full compliance and conformity to all other European regulatory directives and regulations that may also apply.

CE
0359

intertek Testing & Certification Limited
Cloppa Road, Lathford
Dunfermline, Fife, KY12 2JG
Tel: +44 (0)1752 311000
Fax: +44 (0)1752 311077
E-mail: info@intertek.com
www.intertek.com

intertek Testing & Certification Limited
Cloppa Road, Lathford
Dunfermline, Fife, KY12 2JG
Tel: +44 (0)1752 311000
Fax: +44 (0)1752 311077
E-mail: info@intertek.com
www.intertek.com

intertek Testing & Certification Limited
Cloppa Road, Lathford
Dunfermline, Fife, KY12 2JG
Tel: +44 (0)1752 311000
Fax: +44 (0)1752 311077
E-mail: info@intertek.com
www.intertek.com

The facilities at the test site used in the above tests are certified in accordance with the requirements of the relevant standards and are fully compliant with the requirements of the relevant standards. The test results, however, do not constitute a guarantee of the quality of the product. The test results are only valid for the specific product and test methods used in the above tests. The test results are only valid for the specific product and test methods used in the above tests. The test results are only valid for the specific product and test methods used in the above tests.

Page 1 of 2

